

Components and Service Manual Transfer Pump 2.25:1

Issue 2.6

04/11/2025

Ref. NR-00011-ENG



Before installing and operating the pump, carefully read the technical and safety documentation in this manual. Special attention should be paid to the information in order to know and understand the handling and conditions of use of the pump. All of the information is aimed at enhancing user safety and avoiding possible faults due to incorrect use of the pump.



GUARANTEE

HI-TECH SPRAY EQUIPMENT, S. A. (hereinafter "HI-TECH") grants this Limited Guarantee to the original buyer (hereinafter the "Client") for the unit and the original accessories given with the unit (hereinafter the "Product") against any fault in the design, materials or manufacture of the Product at the time of the first purchase by the user and for a duration of two (2) years thereafter, except in the case of hoses and TSU's, which will have a warranty period of one (1) year. Additionally, for any other product manufactured by external suppliers, the warranty period will be as specified by the manufacturer.

If during the guarantee period and under normal conditions of use, the Product should fail to work correctly due to defects of design, material or manufacture, the authorised distributor of the country where the HI-TECH Product or technical assistance service has been purchased shall repair or replace the Product in accordance with what is established in the following:

CONDITIONS

- a) The validity of this guarantee will be subject to the presentation of the original invoice issued by the HI-TECH authorized distributor for the sale of the Product along with the Product handed over for repair or replacement, which must show the date of purchase and the serial number. HI-TECH reserves the right to refuse to give the guarantee service when the indicated data fail to appear on the invoice or have been modified after the purchase of the Product.
- b) The repaired or replaced Product will continue to maintain the original guarantee for the time remaining until the end of the guarantee or for three (3) months from the repair date, if the remaining period of the original guarantee were shorter.
- c) This guarantee will not be applied to the faults in the Product caused by its faulty installation, the natural wear and tear of the components, any use other than that considered normal for this Product or which should fail to strictly comply with the instructions of use provided by HI-TECH; due to accident, carelessness, adjustments, alterations or modifications of the Product not authorized by HI-TECH or due to the use of accessories, heating devices, pumping equipment and/or dispensers that have not been approved or manufactured by HI-TECH.
- d) The guarantee applicable to the components and accessories forming part of the Product and which have not been made by HI-TECH will be limited to the guarantee offered by the original manufacturer thereof.

HI-TECH WILL NOT RECOGNISE ANY EXPRESS ORAL OR WRITTEN GUARANTEES OTHER THAN THIS PRINTED LIMITED GUARANTEE. ALL IMPLICIT GUARANTEES, INCLUDING, WITHOUT LIMIT, ADAPTATION FOR A SPECIFIC USE, ARE SUBJECT TO THE DURATION OF THIS WRITTEN GUARANTEE. HI-TECH DOES NOT ASSUME ANY KIND OF COMMITMENT OR RESPONSIBILITY FOR ALL POSSIBLE DAMAGE OR EXPENSE CAUSED BY FAULTS IN THE OUTPUT OF THE PRODUCT, ITS WORKING OR THE DISPENSING OF MATERIAL THROUGH THE PRODUCT, INCLUDING, WITHOUT LIMITATION, ALL EXPENSES CAUSED BY DAMAGE TO PEOPLE OR PROPERTY. EQUALLY, HI-TECH WILL IN NO CASE ACCEPT LIABILITY FOR THE LOSS OF SPECULATIVE PROFITS OR COMMERCIAL LOSSES. ALL REPAIRS OR REPLACEMENT OF FAULTY PRODUCTS WILL CONSTITUTE THE COMPREHENSIVE FULFILMENT OF HI-TECH'S OBLIGATIONS WITH RESPECT TO THE CLIENT. HI-TECH DOES NOT IN ANY WAY GUARANTEE THE SUITABILITY OR APTITUDE OF ITS PRODUCT FOR ANY PARTICULAR PURPOSE OR APPLICATION.

All of the information provided on components which have not been manufactured by HI-TECH and which is based on reports received from the original manufacturer, though considered precise and reliable, is provided without any guarantee or responsibility of any explicit or implicit kind.

All concession, sale or financial leasing of the Product by HI-TECH in no case explicitly or implicitly constitutes any authorization, acceptance or concession for the use of any rights or patents, nor does it encourage, nurture or back their infringement.

The restrictions on the guarantee suppose no limitation on the legal rights of the consumer established in applicable national legislation, nor do they affect any rights derived from the bargain and sale agreement between the consumer and supplier.



Components & Service Manual

All of the information provided in this manual has been included in the confidence that it is true, although it does not constitute any responsibility or implicit or explicit guarantee. HI-TECH reserves the right at any time and without prior warning to make all improvements and modifications necessary to this manual, in order to rectify any possible typographical errors, increase the information contained or insert the changes caused to the characteristics and performance of the unit.

SAFETY AND HANDLING

The equipment described in this manual has been designed and manufactured in compliance with the following European Directives, following as application guide the harmonized standards detailed and in conformity with the relevant UK Statutory Instruments (and their amendments):

2006/42/EC Machinery Directive

2014/35/EU Low Voltage Directive

2014/30/EU EMC Directive

2011/65/EU RoHS Directive with amendment 2015/863

2012/19/EU Directive on waste electrical and electronic equipment

Standards used:

EN ISO 12100:2010

EN 60204-1:2018

EN IEC 61000-6-4:2019

EN IEC 61000-6-2:2019

EN IEC 63000:2018

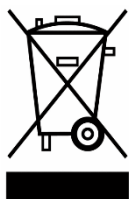

Electrical products cannot be thrown out with the rubbish. They must be taken to a dedicated collection point for an environmentally sound disposal in accordance with local regulations. You must contact your local collective or retailer for information about recycling. Before leaving WEEE at appropriate collection facilities, batteries must be removed and disposed of separately for proper recycling. The packaging materials are recyclable. Dispose of packaging materials in an environmentally sound manner and place them at the disposal of recycling sectors.

TRANSPORT AND STORAGE

Proper precautions must be taken so that the equipment can withstand the effects of transport and storage temperatures between -25°C and $+55^{\circ}\text{C}$ or up to $+70^{\circ}\text{C}$ for short periods that do not exceed 24 hours. Also, appropriate means to prevent damage from moisture, vibrations or shocks must be foreseen.



This chapter contains important information regarding the safety, handling and use of the transfer pump.



Before installing and starting up the pump, carefully read all the technical and safety documentation included in this manual. Special attention should be paid to the information in order to know and understand the handling and conditions of use of the pump. All of the information is aimed at enhancing user safety and avoiding possible faults due to incorrect use of the pump.

A **WARNING!** establishes information to alert on a situation that might cause serious injuries if the instructions are not followed.

A **PRECAUTION!** establishes information that indicates how to avoid damage to the pump or how to avoid a situation that could cause minor injuries.

A **NOTE** is relevant information on a procedure being carried out.

Careful study of this manual will help you to become more acquainted with the pump and the procedures. Following the instructions and recommendations here will reduce the potential risk of accidents in installing, using or maintaining the pump, and will give you the problem-free operation for a longer time, greater output and the possibility of detecting and resolving problems quickly and simply.

Keep this Service Manual for future consultation of useful information at all times. If you lose the manual, ask for a new copy from your local **HI-TECH** distributor or make direct contact with **HI-TECH Spray Equipment, S. A.**

These instructions must be complemented by the national requisites in order to prevent accidents and protect the environment.

When working with the pump, it is essential to dress suitably and use personal protective equipment, including the unlimited use of gloves, protective goggles, safety footwear and face masks. Use breathing equipment when working with the pump in enclosed or insufficiently ventilated atmospheres. The introduction and monitoring of safety measures must not be limited to those described in this manual. Before starting to use the pump, a rigorous analysis must be made of the risks derived from the products to be dispensed, the type of application and the working environment.



To prevent all possible body harm caused by incorrect handling of the raw materials and solvents used in the process, carefully read the safety information provided by your supplier.

Deal with all waste according to each country's current regulations.



The high speed of the product flowing through the conducts might cause static electricity shown by small shocks and sparks. The pump should be grounded.

WARNING! *In potentially explosive atmosphere, the ground connection must be made before the pump is brought into operation.*



To avoid damage caused by the impact of pressurized fluids, do not open any connection or perform maintenance work on components subject to pressure until the pressures have been completely eliminated.

Use suitable protection when operating, maintaining or remaining in the operating area of the pump. This includes, but is not limited to, the use of masks, protective goggles, gloves, shoes and safety clothing.



Do not touch the sleeve of the pneumatic motor. The air decompression that drives the piston cools the surface considerably after a few minutes of operation, which might cause freezing in contact with the skin. Use gloves or allow the surface to warm in all maintenance work.



To prevent serious harm by crushing or loss of limbs, do not work with the unit without the safety protections duly installed on all moving parts. Make sure that all of the safety protections are correctly fitted after all repair or maintenance work.



TYPICAL INSTALLATION

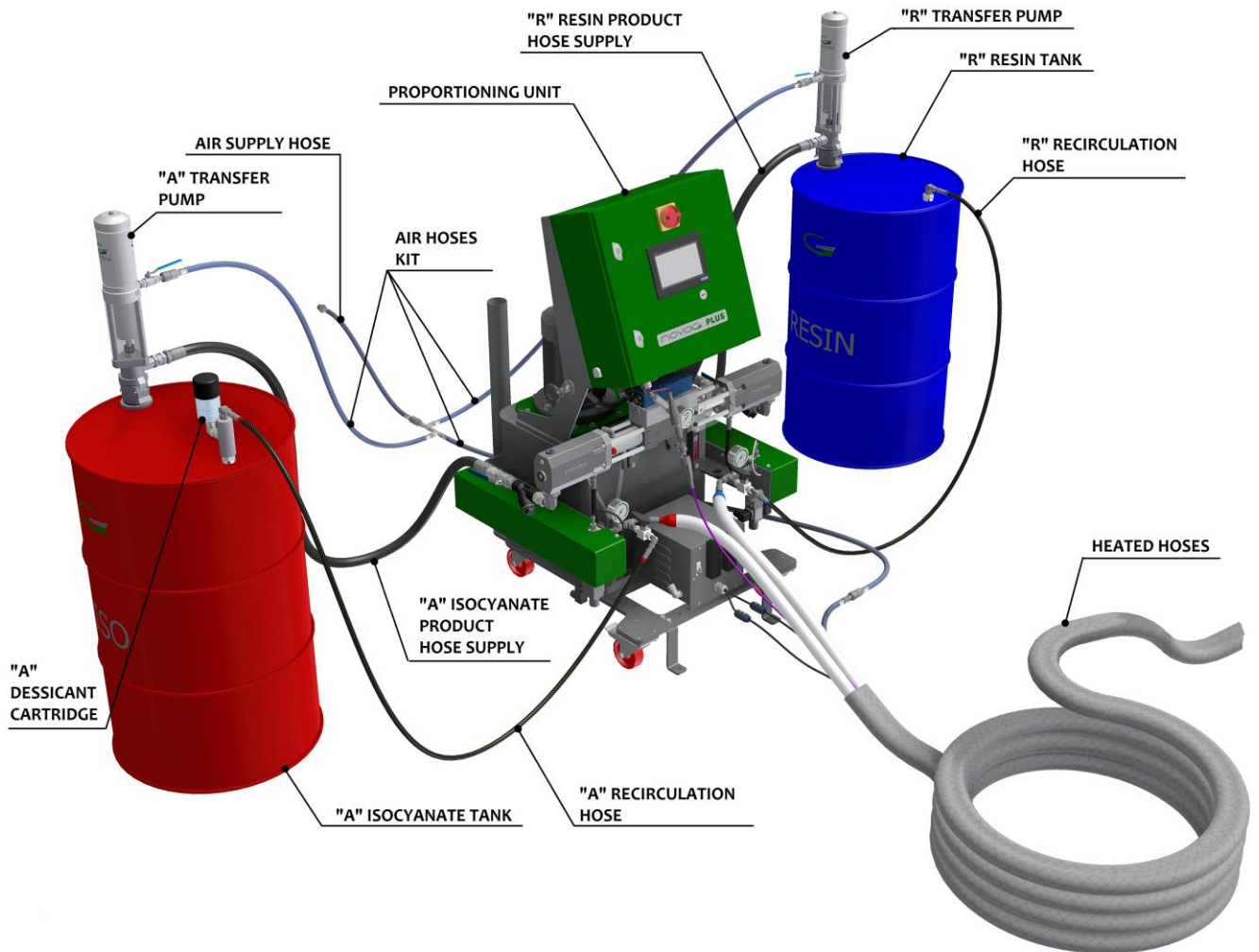

Figure 1. Typical Installation in a hydraulic unit with recirculation.



DESCRIPTION

The **HI-TECH 2.25:1** pump is a pneumatically-driven, double effect, alternating pump used for moving liquids with a maximum viscosity of 2,000 mPas.

The compressed air causes the alternating rising and falling movement in the pneumatic piston, which is transmitted by means of a connection rod to the plungers of the upper and lower chamber of the pump, thereby sucking and driving the fluid.

The fluid output pressure is 2.25 times higher than the air pressure causing the movement of the pneumatic piston.

All materials coming into contact with the fluid are made in stainless steel of the highest quality.



OPERATION DIAGRAM

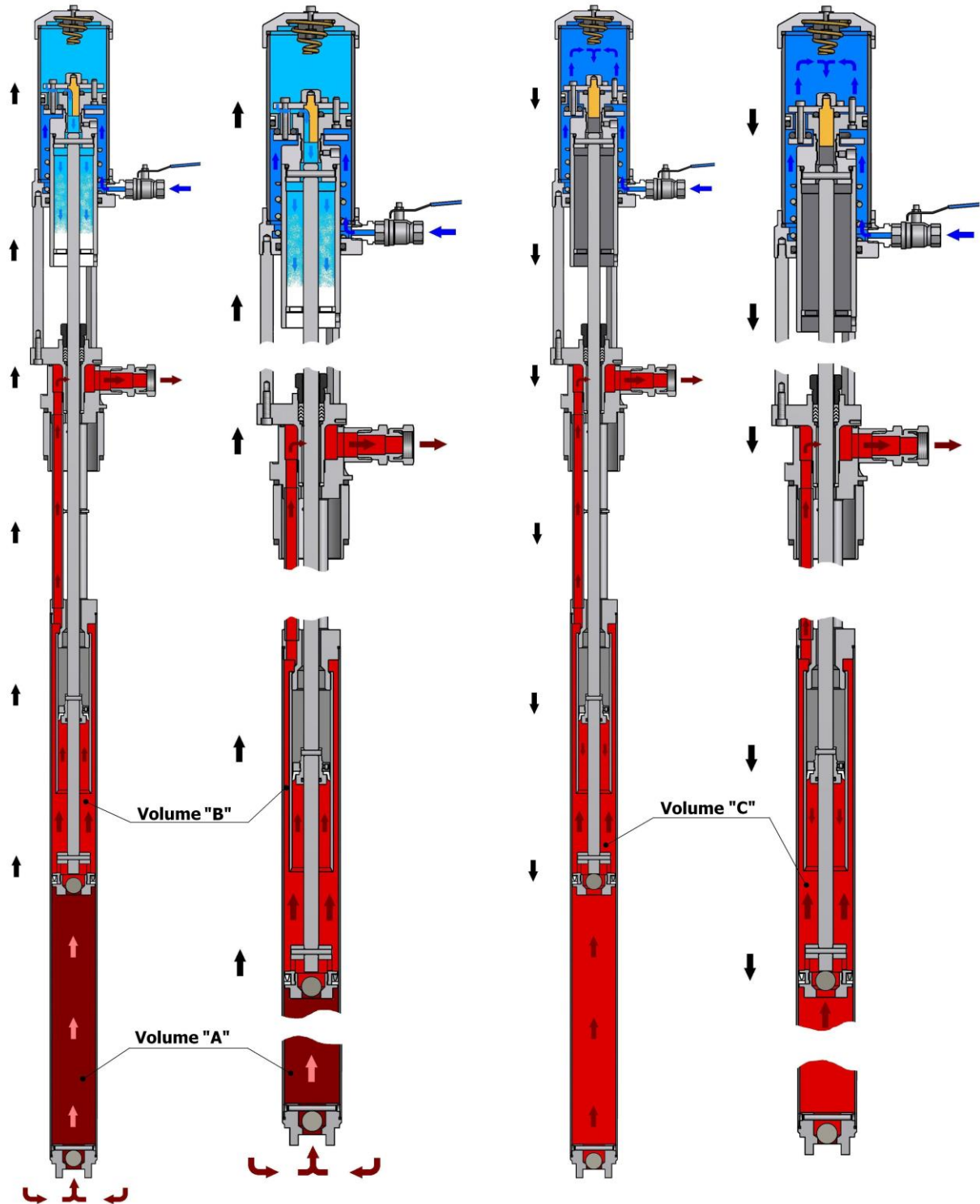

Figure 2. Operation Diagram



PNEUMATIC MOTOR OPERATION

Process of reversing the movement of the pneumatic piston.

- The pump movement is reversed thanks to a floating mechanism in the pneumatic piston. When it rises, the air in the lower chamber of the piston pushes it upwards, the air in the upper chamber is decompressed and released from the motor through the piston shaft.
- When the piston makes contact with the upper spring, a valve is opened inside it that allows the air entering the motor to go straight into the upper chamber, thus pushing the piston down.
- When the piston makes contact with the lower spring, the internal valve is closed and the air pressure pushes the piston upwards, whereas the pressurized air in the upper chamber is released through the piston shaft.

PUMPING MECHANISM OPERATION

Up stroke (see Figure 2 left side)

- The lower plunger of the pump rises and keeps the valve of the upper plunger closed, pushing the product in the upper chamber to the pump outlet (volume "B"). The depression produced in the lower chamber of the plunger in the rising movement opens the ball of the lower valve, thus sucking the fluid in from the vessel (volume "A").

Down stroke (see Figure 2 right side)

- The lower plunger of the pump moves downwards and exerts pressure on the lower ball, closing it mechanically. The same downwards movement opens the ball of the upper valve, allowing the fluid from volume "A" into the intermediate chamber and the surplus material (half of volume "A") is moved to the pump outlet (volume "C").

N.B.: The pump only sucks material when it rises (Volume "A"), but drives material when it rises (Volume "B") and when it falls (Volume "C").

$$\text{Volume "A"} = \text{Volume "B"} + \text{Volume "C"}.$$



TECHNICAL SPECIFICATIONS

Pressure ratio: _____ 2.25:1 (@ 7 bar air – 15.7 bar product)
 Maximum fluid pressure: _____ 22.5 bar / 2.25 MPa
 Maximum air inlet pressure: _____ 10 bar / 1 MPa
 Maximum fluid temperature: _____ 85°C.
 Maximum outlet volume: _____ 20.8L./min
 Piston movement: _____ 101.6mm (4")
 Suction volume (only rising): _____ 206cm³
 Transfer volume (by stroke/cycle): _____ 103cm³/206cm³
 Volume of consumed air (by stroke/cycle) @ 7 bar: _____ 1.6L/3.2L
 N. cycles to transfer 1 litre: _____ 4.85
 Weight: _____ 10.5Kg (23.15lb)
 Air connection: _____ 1/4"NPT
 Product outlet connection: _____ 3/4"NPT
 A-weighted sound pressure level: _____ 82.3 (A) dB
 A-weighted sound power level: _____ 92.9 (A) dB

Values obtained according to UNE-EN ISO 3746:1995 standard.

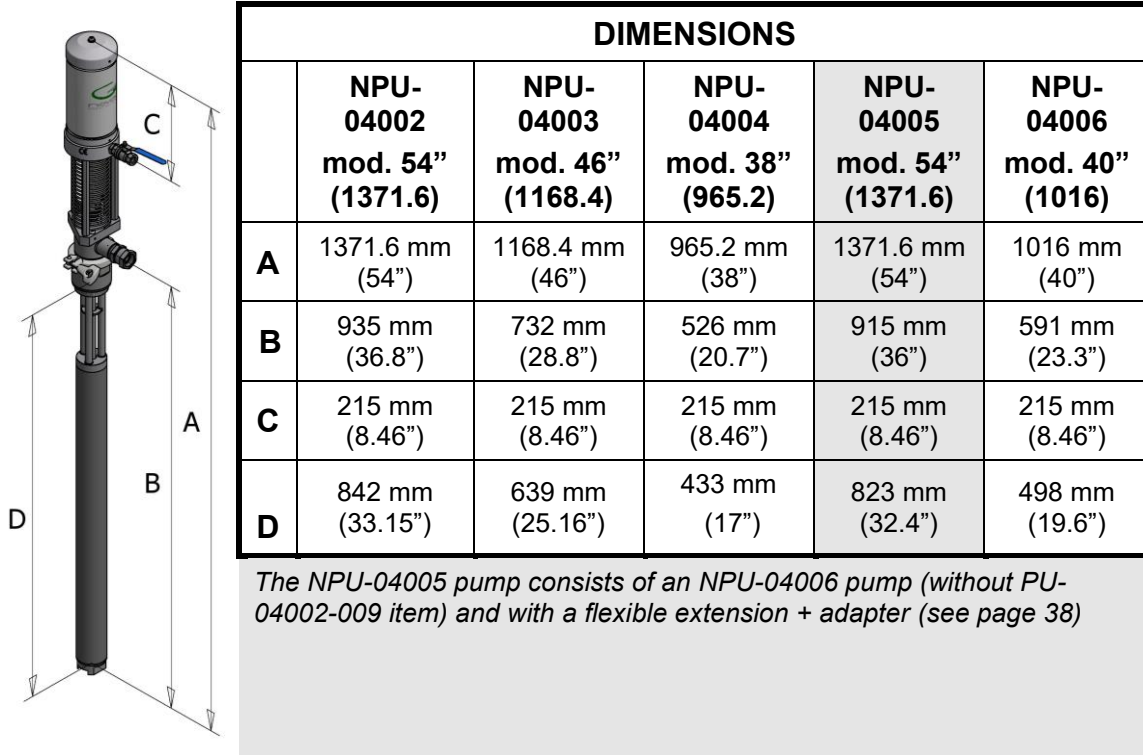

Figure 3. General Dimensions



KITS LIST OF TRANSFER PUMPS

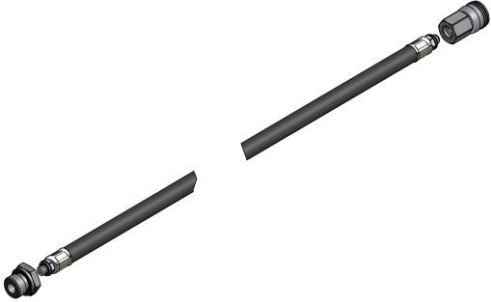

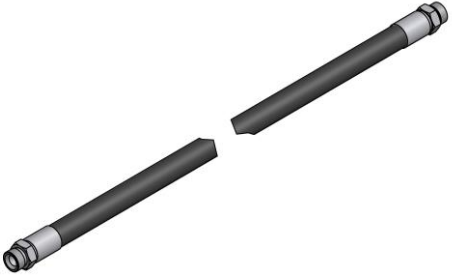

**Table 1. Kits List of Transfer Pumps
According to model Unit, Length & Pump Size**

	HOSES LENGTH.	HI-TECH-III, HI-TECH III PLUS HI-TECH-V, HI-TECH V PLUS G-Connect, G-Connect+
NPU-04002 (54" PUMP)	3,5 m	NE-00072
	5 m	-
NPU-04003 (46" PUMP)	3,5 m	NE-00072-01
	5 m	-
NPU-04006 (40" PUMP)	3,5 m	NE-00080
	5 m	
NPU-04004 (38" PUMP)	3,5 m	NE-00073
	5 m	
NPU-04005 (40"+14" PUMP)	3,5 m	NE-
	5 m	



TRANSFER PUMPS KITS

Table 2. Transfer Pump Kit NE-00072, Parts List

NPU-04002	2x Machine	54" Standard Transfer Pum Assy
Connection kit for air compressor. For hydraulic machines		
MA-00034	1x machine / 1x 2 Pumps	
Air supply connection kit for hydraulic machines		
MA-00035	1x machine / 1x 2 Pumps	
Product hose:		
MA-00026	2x machine / 1x Pump	
Product outlet connection:		
RA-00212	2x machine / 1x Pump	

Transfer Pump 2.25:1

Components & Service Manual



Table 3. Transfer Pump Kit NE-00072-01, Parts List









NPU-04003	2x Machine	46" Short Transfer Pum Assy
<p>Connection kit for air compressor. For hydraulic machines</p> <p>MA-00034</p> <p>1x machine / 1x 2 Pumps</p>		
<p>Air supply connection kit for hydraulic machines</p> <p>MA-00035</p> <p>1x machine / 1x 2 Pumps</p>		
<p>Product hose:</p> <p>MA-00026</p> <p>2x machine / 1x Pump</p>		
<p>Product outlet connection:</p> <p>RA-00212</p> <p>2x machine / 1x Pump</p>		

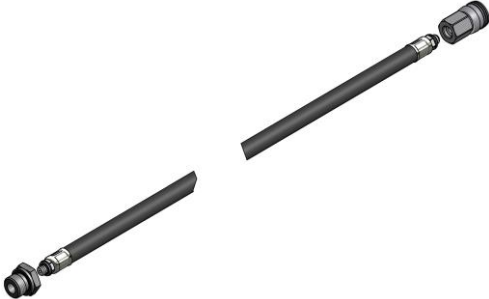

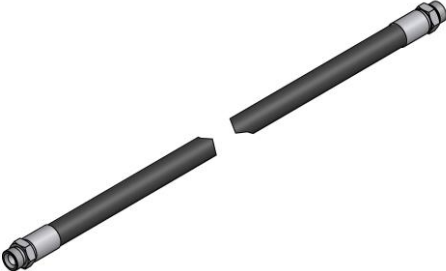
Table 4. Transfer Pump Kit NE-00080, Parts List

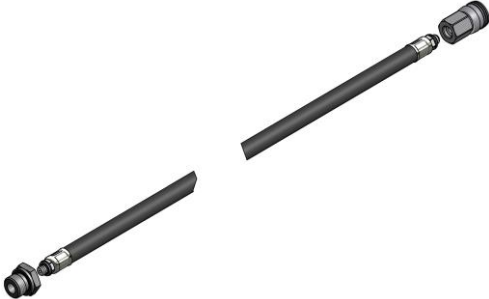
NPU-04006	2x Machine	40" Short Transfer Pum Assy
<p>Connection kit for air compressor. For hydraulic machines</p> <p>MA-00034</p> <p>1x machine / 1x 2 Pumps</p>		
<p>Air supply connection kit for hydraulic machines</p> <p>MA-00035</p> <p>1x machine / 1x 2 Pumps</p>		
<p>Product hose:</p> <p>MA-00026</p> <p>2x machine / 1x Pump</p>		
<p>Product outlet connection:</p> <p>RA-00212</p> <p>2x machine / 1x Pump</p>		

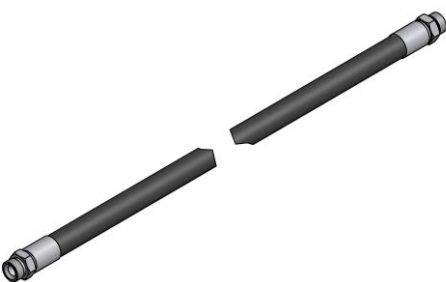
Transfer Pump 2.25:1

Components & Service Manual



Table 5. Transfer Pump Kit NE-00073, Parts List









NPU-04004	2x Machine	38" Standard Transfer Pum Assy
<p>Connection kit for air compressor. For hydraulic machines</p> <p>MA-00034</p> <p>1x machine / 1x 2 Pumps</p>		
<p>Air supply connection kit for hydraulic machines</p> <p>MA-00035</p> <p>1x machine / 1x 2 Pumps</p>		
<p>Product hose:</p> <p>MA-00026</p> <p>2x machine / 1x Pump</p>		
<p>Product outlet connection:</p> <p>RA-00212</p> <p>2x machine / 1x Pump</p>		

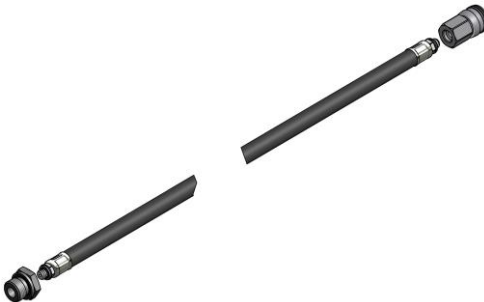

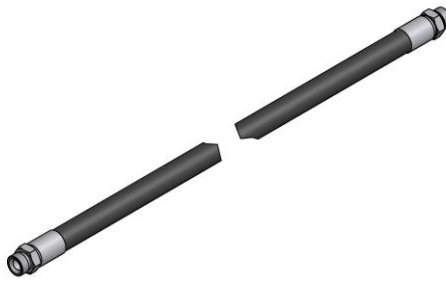
Table 6. Transfer Pump Kit NE-, Parts List

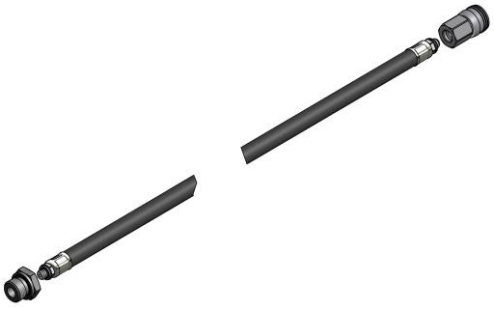
NPU-04005	2x Machine	(40"+14") Standard Transfer Pum Assy with Flexo)
Connection kit for air compressor. For hydraulic machines		
MA-00034	1x machine / 1x 2 Pumps	
Air supply connection kit for hydraulic machines		
MA-00035	1x machine / 1x 2 Pumps	
Product hose:		
MA-00026	2x machine / 1x Pump	
Product outlet connection:		
RA-00212	2x machine / 1x Pump	

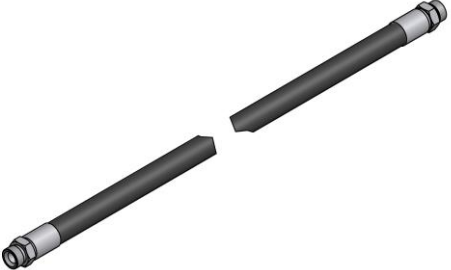

INSTALLATION

Reception

Although all precautions are taken in packing and sending in the factory, the goods must be checked when they are received. Make sure that all the parts and accessories on the remittance are correct and have not been damaged in transport.

In the package, along with the pump you must receive 2 tools for tightening the stop valves (HT-00077).

Storage

If the pump is going to be stored before installation, leave it in a clean and dry place. Do not remove the protection caps from the connections to prevent dirt from entering the pump.

Assembly

1. Thread the transfer pump adapter onto the drum. Make sure that it includes the corresponding gasket. Insert the pump into the adapter. Close the clamp and ensure that both the pump and the adapter are firmly attached.

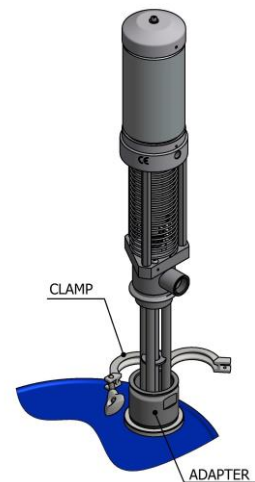

2. Screw the 1/4"NPT-1/4"BSP thread adapter and the ball valve on to the pump, placing sealing paste or teflon tape on the threads to ensure that the unit is properly sealed. Make sure that the ball valve is closed. Do not connect the network air supply yet.

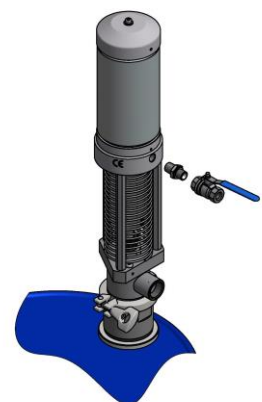

N.B.: The thread adapter and the ball valve are not supplied with the pump. These parts are included in Transfer Pump Kits (See Table 1).



3. Screw the RA-00012 product outlet connector on the 3/4"NPT thread of the pump.

N.B.: The connector is not supplied with the pump. This Part is included in Transfer Pump Kits (see Table 1)

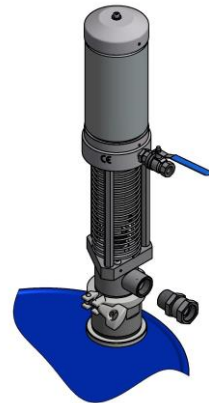

The high speed of the product flowing through the conducts might cause static electricity shown by small shocks and sparks. The pump should be grounded with a wire connected to mass on the fixture provided.

WARNING! In potentially explosive atmospheres or with flammable products, the ground connection must be made before the pump is brought into operation.

4. A wire may be used with a peeled end, which is inserted through the protection in the drill hole provided and fixed with the bolt (figure on the left), or, if you prefer, a wire may be used with a terminal for M6 bolt, which is fixed as shown in the drawing (figure on the right).

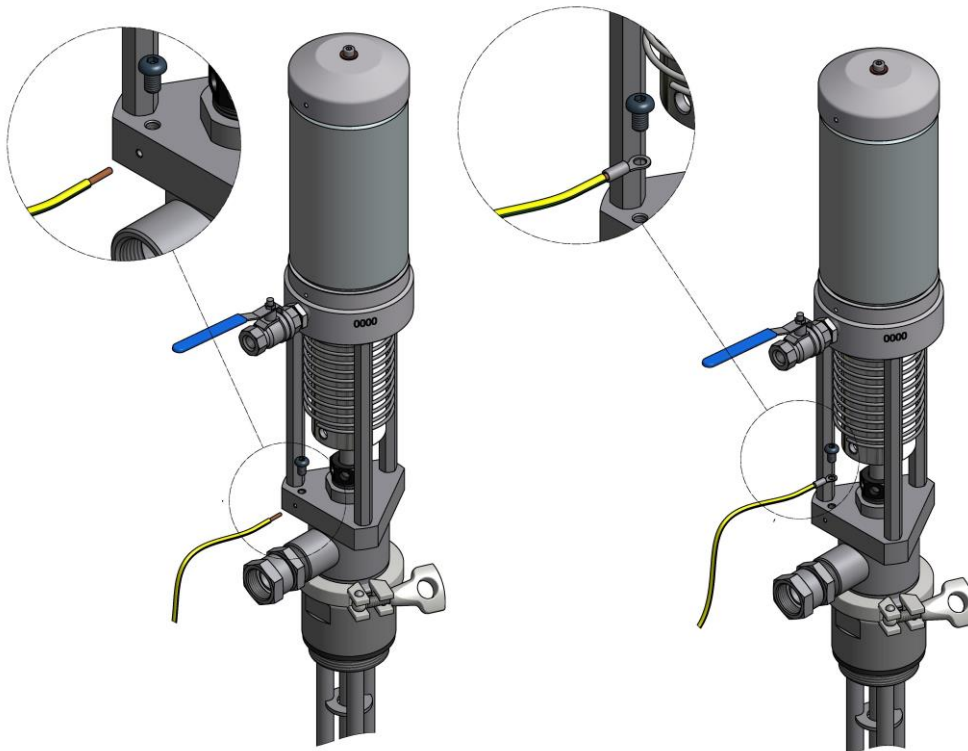

Transfer Pump 2.25:1



Components & Service Manual

5. Screw MA-00026 product hose on the pump connection and the machine valve. Place sealing paste or Teflon tape on the threads to ensure that the unit is sealed.

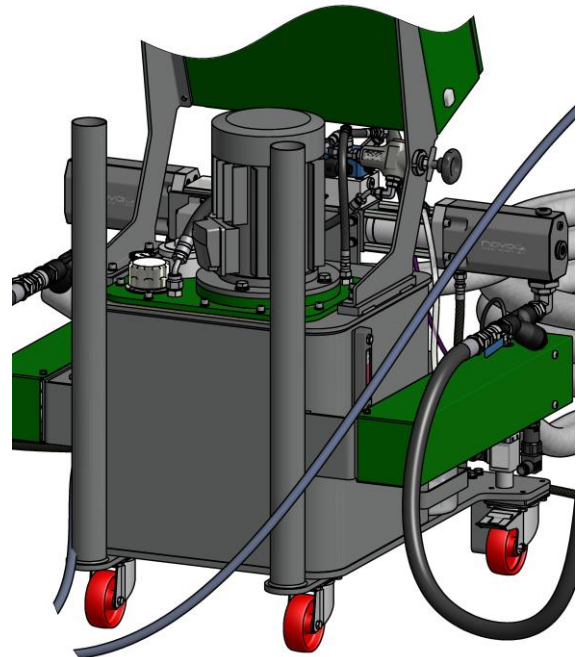
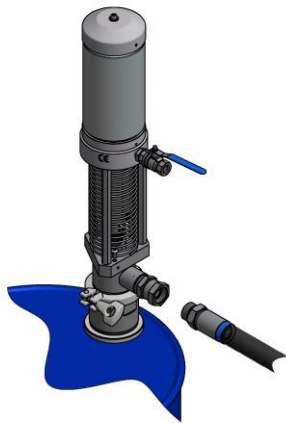

N.B.: The MA-00026 hose is not supplied with the pump. This Part is included in the Transfer Pump Kits (see Table 1).

6. Open the ball valve on the machine inlet.
7. Now connect the air supply hose and open the air valve on the machine to start the transfer pump.

Do this by slowly opening the valve until the pump piston begins to move. Use the valve opening to control the speed of the pump.

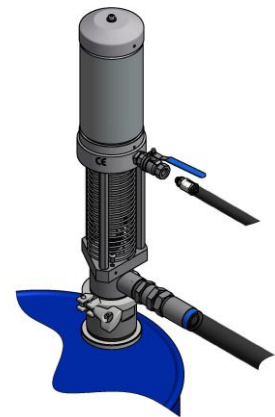
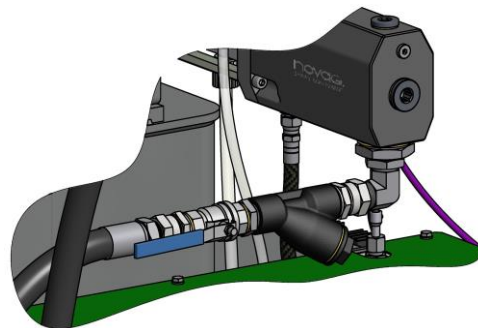

The transfer pump is used to transfer both isocyanates and polyols. However, once one of the two products has passed through it, it is recommendable to identify it by marking it clearly and visibly in order to know which product it contains or which product has been transferred. Any mistake putting it into the wrong product drum or attaching the wrong hose connection would contaminate the pump and render it useless.

Never allow the pump to continue working without product, as this could rapidly damage the seals. Stop the pump if you see that it accelerates fast or moves too rapidly.



STOPPING METHOD

When you want to stop the pump, shut off the air supply with the ball valve, and then disconnect the air connector.

If the pump is going to be shut down for a short time, it is best not to empty it as this prevents air and damp from entering and avoids any contamination.

If the pump is to be shut down for a long period of time, it must be completely emptied of product and carefully and thoroughly cleaned with a cleaning agent (DOTP). It must then be stored in a clean, dry place.



WARNING! Do not touch the sleeve of the pneumatic motor. The air decompression that drives the piston cools the surface considerably after a few minutes of operation, which might cause freezing in contact with the skin. Use gloves or allow the surface to warm in all maintenance work.

CLEANING

Cleaning is understood as the cleaning that has to be done before using a different product or when a long period of inactivity is expected for the pump and the metering unit.

Follow the recommended procedure in the order indicated to perform the cleaning when you have to change the components of the system:

- a) Place two drums of DOTP cleaning agent near the metering unit.
- b) Remove the gun and leave the coupling block connected to the hoses.
- c) Remove the transfer pumps from the drums of product and place them in the drums of DOTP cleaning agent.
- d) Place a vessel under the coupling block to gather up the products contained inside the machine.
- e) Open the taps of the coupling block and start up the metering unit.
Make sure the machine product inlet valves and the air inlets valves to the pumps are open.
- f) Allow the products to come out until you see that only DOTP cleaning agent comes out free of impurities.
- g) Close the taps of the coupling block and stop the metering unit.
- h) Close the air inlet taps to the pumps and place the transfer pumps in the drums of the new products.

Transfer Pump 2.25:1



Components & Service Manual

- i) Place a vessel under the coupling block to collect the DOTP cleaning agent.
- j) Open the taps of the coupling block and start up the metering unit.
- k) Open the air inlet valves to the pumps.
- m) Allow DOTP cleaning agent to come out until you see that only the new products come out.
- n) When the products come out without the contamination produced by the effect of the DOTP cleaning agent, the cleaning process is complete and you can proceed as normal.

If a long period of inactivity is expected, it is advisable to suck in DOTP cleaning agent and leave it inside the pump. It must then be stored in a clean, dry place.

N.B.: Keep all hazardous fluids in suitable containers. These products have to be eliminated according to the current laws of each country.



DISMANTLING AND MAINTENANCE

WARNING! Before dismantling the pump or carrying out maintenance on it, disconnect the air supply and depressurize the pump.

N.B.: All of the threads of the different components in the pump are tightened clockwise.

N.B.: If you are going to replace a kit of seals, replace all of those included in the kit supplied. Although there may seem to be seals in a good state, the combination of new seals with seals that have been worn by the accumulated work can cause the pump to work badly.

1. To facilitate the pump dismantling and assembly, place it in a vice, holding it by the triangular base of the body.

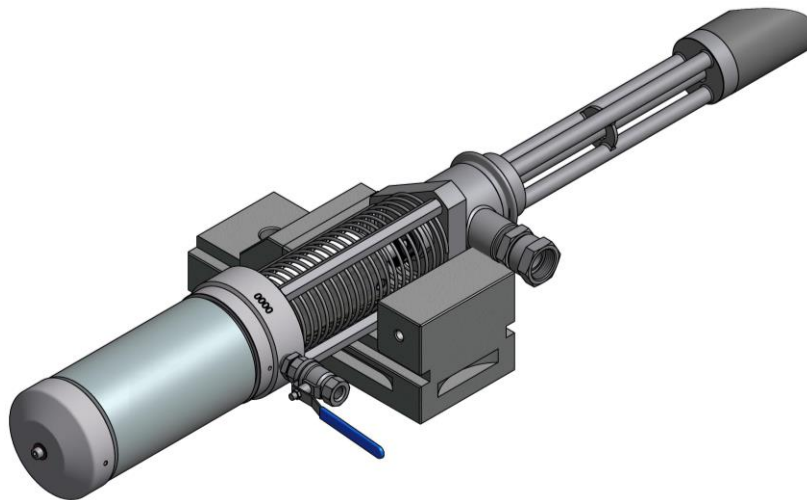

Transfer Pump 2.25:1

Components & Service Manual



2. Unscrew the pump suction valve using a 42mm or 1 5/8" spanner (not supplied).

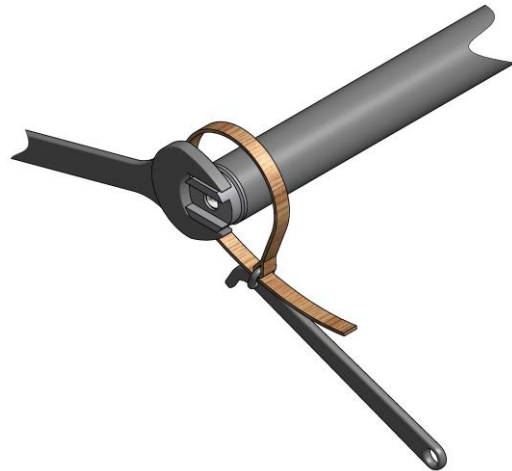

Use a belt spanner (not supplied) to loosen the valve, if necessary, placing it as close as possible to the end of the pipe in order to avoid deformations.



The pneumatic cylinder contains pressurized air that must be removed before dismantling. All failure to observe this step can cause serious injuries.

3. Depressurize the pneumatic cylinder as follows:
 - Disconnect the air supply.
 - Open the air inlet valve.
 - Loosen the purging screw of the pneumatic cylinder on the top cover.

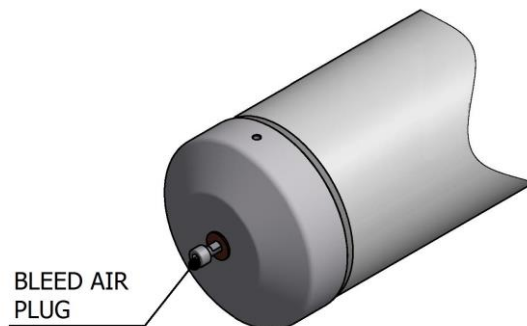

Now you can dismantle the pump.

4. Using a strap wrench (not supplied), hold the air jacket and unthread it from the lower cylinder head. .

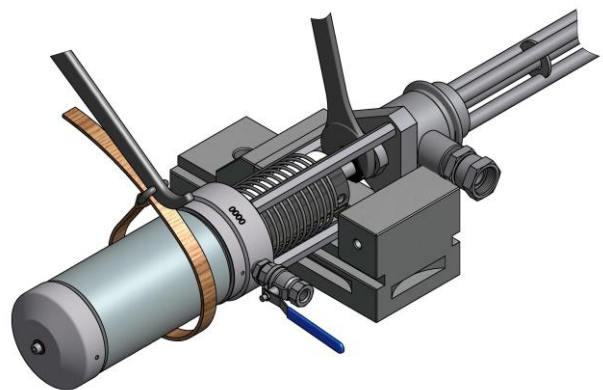



5. Use the two pins (HT-00077 supplied with the pump) with a diameter of 8 mm (or 5/16"), to unscrew the lower chrome guide of the plunger.

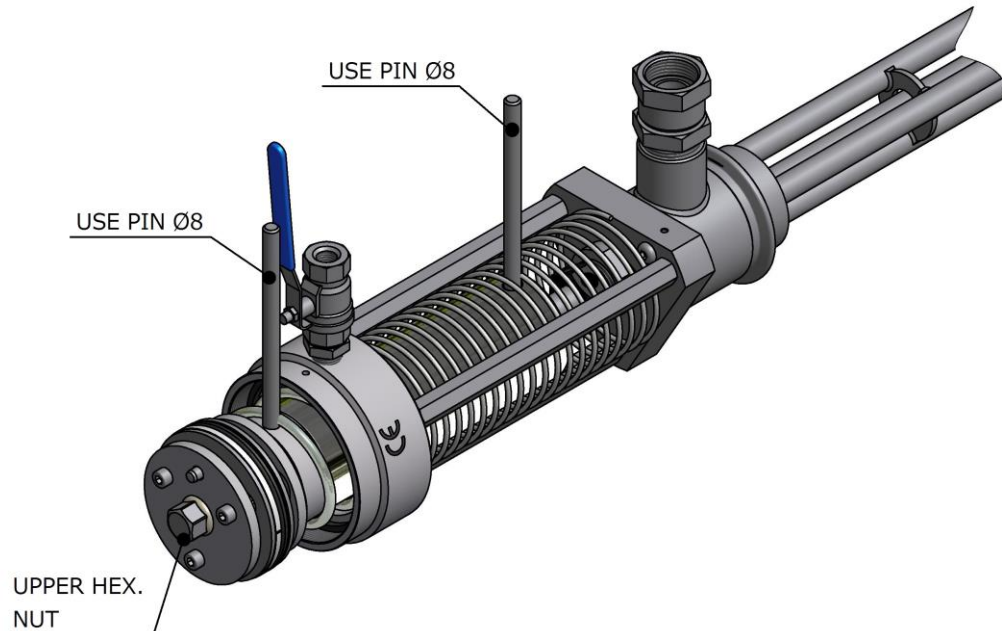

WARNING! Do not use the hexagonal geometry of the upper nut of the plunger to loosen and unscrew the rod as this can cause irreparable damage to the plunger interior mechanism.

6. Remove the pin fixing the piston and the rod.

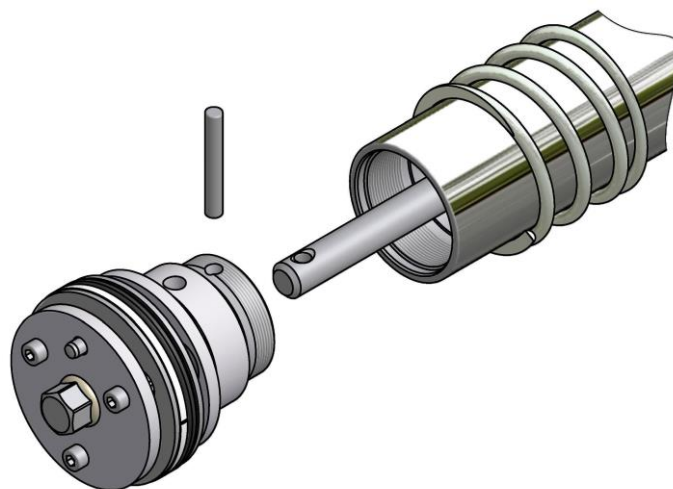

Transfer Pump 2.25:1

Components & Service Manual



7. Loosen the nut holding the stop valve, push the rod and remove the lower plunger from the pump through the lower suction sleeve.



8. Inspect the seals and replace as necessary.
Pay special attention to the direction of the seals when fitting.

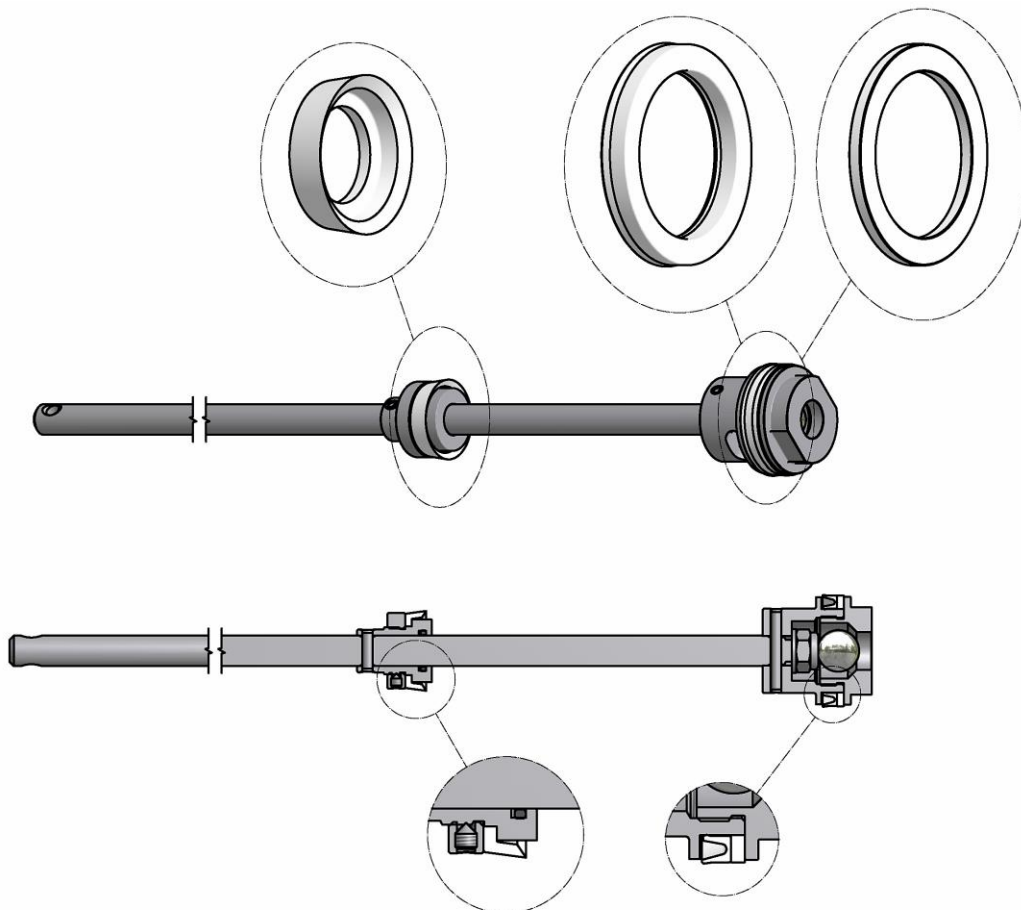

9. Lubricate and fit all parts in reverse order to the process described above.



TROUBLESHOOTING

Problem	Cause	Solution
The pump does not work	The supply air pressure is very low	Check the air supply line and increase the diameter of the supply pipe. Increase the inlet pressure.
	The supply air flow is insufficient	Check the air supply line and increase the diameter of the supply pipe. Open the air inlet valve completely.
	Worn pneumatic piston seals	Replace all worn seals
The pump works too fast	Lack of product	Add product
	Lower valve worn or partially obstructed	Remove the valve, clean it and replace all worn parts as necessary
	Upper valve worn or partially obstructed	Remove the valve, clean it and replace all worn parts as necessary
The pump works, but not enough product comes out	Lower valve worn or partially obstructed	Remove the valve, clean it and replace all worn parts as necessary
	Product outlet line obstructed	Disconnect the outlet hose, feed the product with minimum pressure and check whether the flow increases
	The supply air pressure is too low	Increase the air pressure.
The pump loses product above the upper chamber	Upper chamber piston seal loose or worn	Tighten or replace the seal



METHOD OF THREADED UNION OF THE HOSES

Follow the torques for threaded joints listed in **Table 7** according to thread sizes of hose fittings to ensure their proper assembly.

There is also an alternative procedure to obtain an equivalent torque without using special tools: joint both ends of the hoses to be connected, tighten a swivel nut by hand (without using spanner) until there is resistance on the nut. Fit two spanners (1) on the fixed ends of the hoses and turn the swivel nut with a third spanner (2) as many flats from wrench resistance (FFWR) as indicated in **Table 7**.

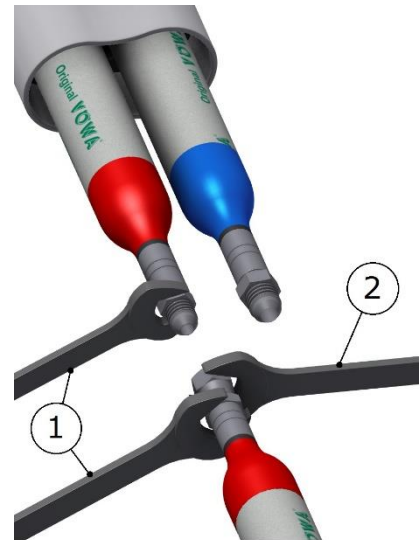
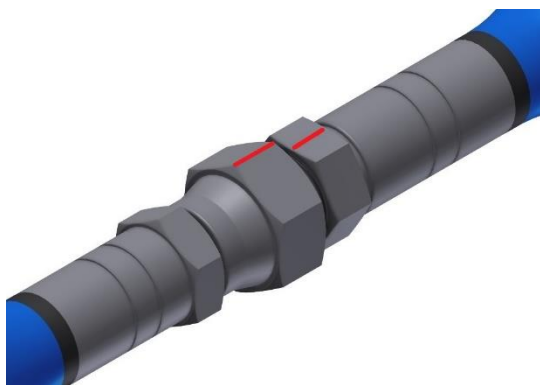

Table 7. Tightening Threaded Joints		
THREAD SIZE	TORQUE Nm	FFWR
1/2"-20	23	2 (or 120°)
9/16"-18	30	1-1/2 (or 90°)

NOTE: 1 FFWR corresponds to one complete shear of a flat marked with red between swivel and fitting or else 60°.





COMPONENT IDENTIFICATION

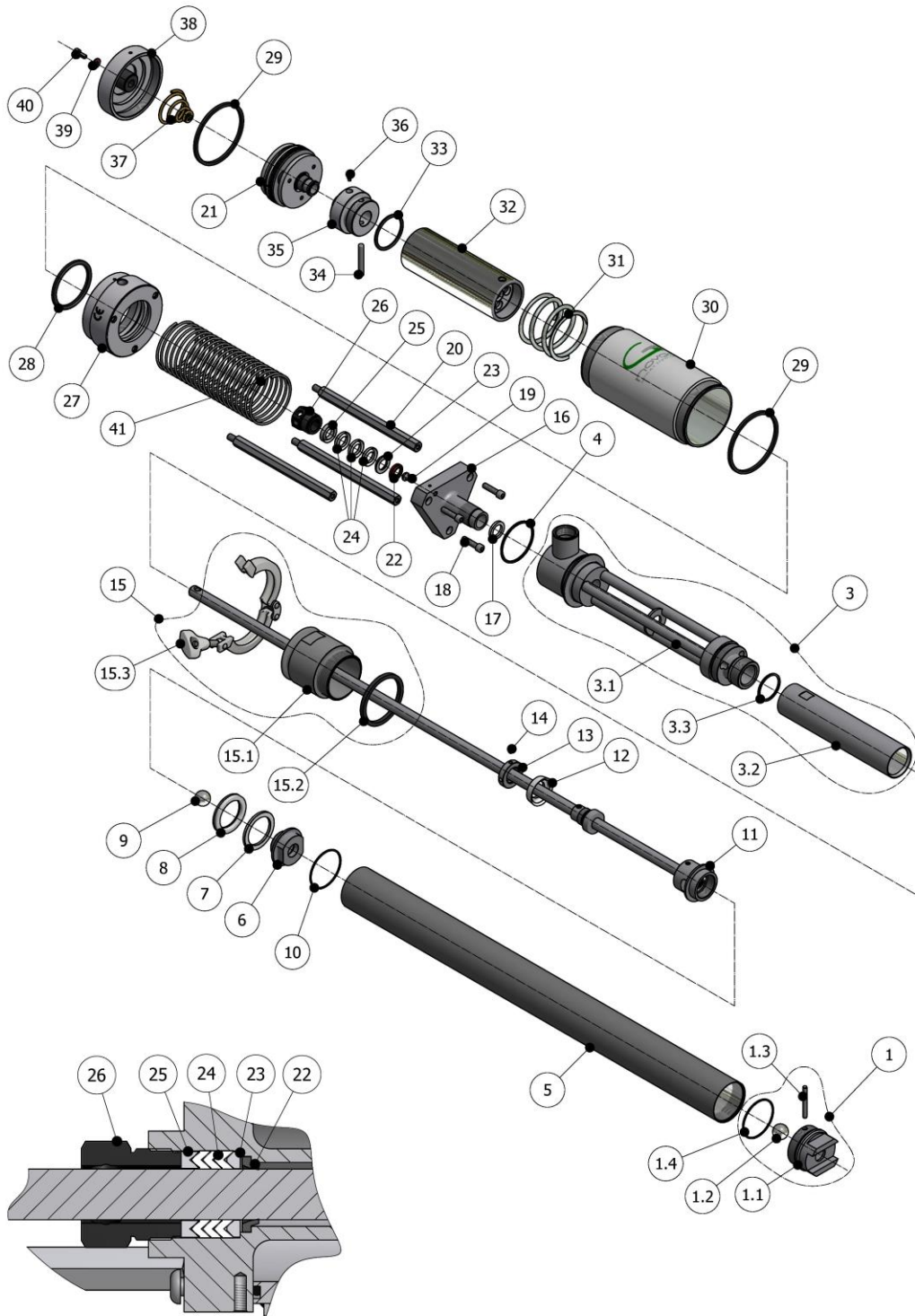

Figure 4. General Diagram.

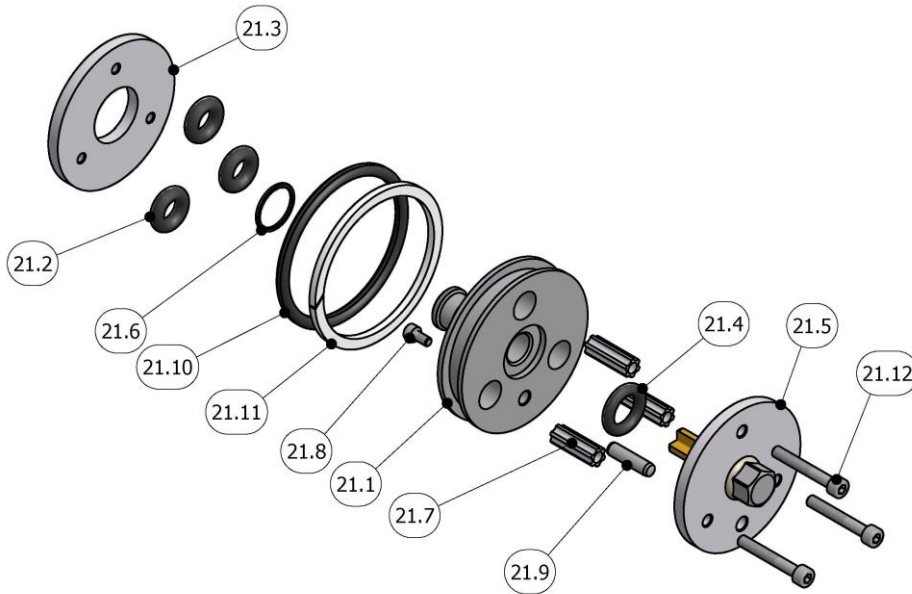

Figure 5. Details of Diagram of Upper Plunger (Pneumatic).

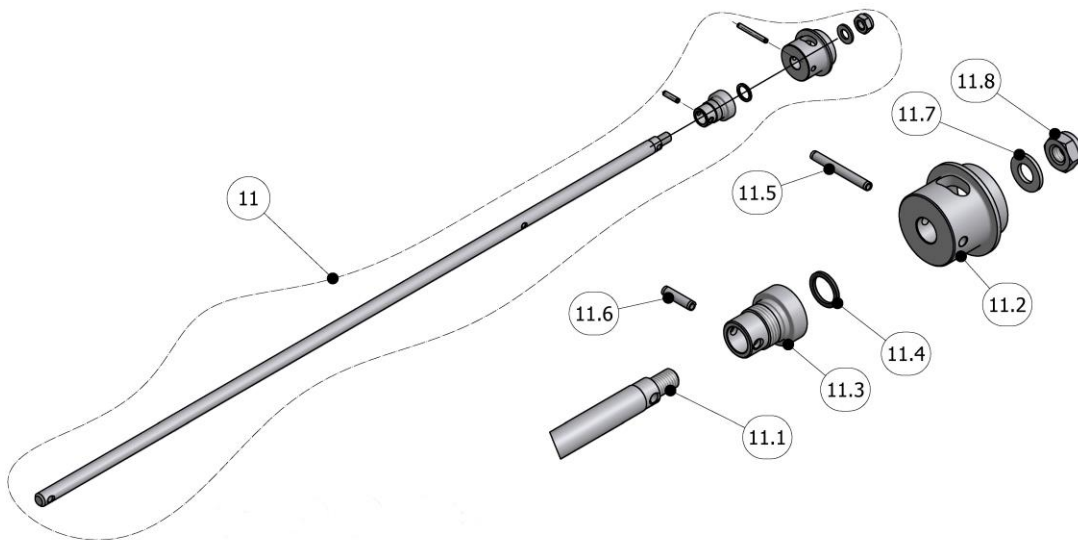

Figure 6. Details of Diagram of Lower Plunger.



Table 8. List of Components

Pos.	Description	Reference	Qty.
1	Suction Valve Unit (includes Pos.1.1 to 1.4)	PU-04002-009	1
1.1	Valve Body	PU-04002-010	1
1.2	Ball	PU-04000-090	1
1.3	Pin	TN-00308	1
1.4	O-ring (*)	OR-00107	1
2			
3	Pump Body Unit (includes Pos.3.1 and 3.2)	See Table 9	1
3.1	Pump Body	See Table 9	1
3.2	Pump Body Interior Sleeve	PU-04002-008	1
3.3	O-ring (*)	OR-00150	1
4	O-ring (*)	OR-00009	1
5	Pump Suction Sleeve	See Table 9	1
6	Pump Plunger Cover	PU-04000-053	1
7	Pump Lower Plunger Guide (*)	PU04000-067	1
8	Lower Pump U-Cup Seal (*)	PU-04000-070	1
9	Ball	PU-04000-090	1
10	O-ring (*)	OR-00107	1
11	Pump Body Unit (includes Pos.11.1 to 11.8)	See Table 9	1
11.1	Pump Rod	See Table 9	1
11.2	Lower Plunger Head	PU-04002-033	1
11.3	Pump Upper Stop Valve Plunger	PU-04002-034	1
11.4	O-ring (*)	OR-00114	1
11.5	Pin	TN-00302	1
11.6	Pin	TN-00303	1
11.7	Washer	TN-00145	1
11.8	Lock Nut	TN-00165	1
12	Pump Upper Plunger Lip Seal (*)	PU-04000-069	1
13	Stop Valve Nut	PU-04000-059	1
14	Trap	TN-00304	1

Transfer Pump 2.25:1



Components & Service Manual

Pos.	Description	Reference	Qty.
15	Pump Clamp Unit (includes Pos.15.1 to 15.3)	See Table 10	1
15.1	Pump Coupling Body	See Table 10	1
15.2	Pump Base seal (*)	PU-04000-040	1
15.3	Pump clamp	TN-00497	1
16	Pump Outlet Body Cover	PU-04002-012	1
17	Test Seat Seal	PU-04000-068	1
18	Bolt	TN-00306	3
19	Bolt	TN-00248	1
20	Air Cylinder Stay	PU-04000-063	3
21	Pneumatic Plunger Unit (includes Pos.21.1 to 21.12)	PU-04002-018	1
21.1	Pneumatic Plunger Body	PU-04002-019	1
21.2	O-ring (*)	OR-00108	3
21.3	Plunger Lower Disk	PU-04002-020	1
21.4	O-ring (*)	OR-00109	1
21.5	Upper Plunger Disk Unit (includes Pos. 21.5.1 to 21.5.4)	PU-04002-021	1
21.5.1	Upper Disk (#)	PU-04002-022	1
21.5.2	Plunger Interior Core (#)	PU-04002-023	1
21.5.3	Upper Plunger Stop (#)	PU-04002-024	1
21.5.4	Sealing Resin (#)	-	1
21.6	O-ring (*)	OR-00110	1
21.7	Pneumatic Plunger Spacer	PU-04002-025	3
21.8	Allen Bolt	TN-00018	1
21.9	Pin	TN-00307	1
21.10	O-ring (*)	OR-00111	1
21.11	Plunger Guide (*)	PU-04002-026	1
21.12	Allen Bolt	TN-00298	3
22	Lip Seal (*)	PU-04002-013	1
23	Stop Valve Lower Support	PU-04002-014	1
24	Stop Valve Segment (*)	PU-04002-015	3
25	Stop Valve Upper Support	PU-04002-016	1
26	Stop Valve Nut	PU-04000-061	1



Pos.	Description	Reference	Qty.
27	Air Cylinder Base	PU-04002-017	1
28	O-ring (*)	OR-00112	1
29	Cylinder Base Seal (*)	PU-04000-081	2
30	Pneumatic Cylinder Sleeve	NPU-04000-062	1
31	Lower Spring	PU-04000-073	1
32	Pneumatic Plunger Shaft Unit (include Pos.32.1 to 32.2)	PU-04002-028	1
32.1	Air Plunger Shaft (#)	PU-04002-029	1
32.2	Guide Insert (#)	PU-04002-030	1
33	O-ring (*)	OR-00113	1
34	Pin	TN-00301	1
35	Pneumatic Rod Head	PU-04002-027	1
36	Trap	TN-00299	1
37	Cylinder Pan Conic Spring	PU-04000-072	1
38	Cylinder Pan Unit (includes Pos.38.1 to 38.2)	PU-04002-035	1
38.1	Air Cylinder Pan (#)	PU-04002-036	1
38.2	Elastic Stopper (#)	PU-04002-037	1
39	Air Purge Bolt Seal (*)	PU-04000-077	1
40	Air Purge Bolt	PU-04000-057	1
41	Spring	SP-00046	1
42			

All parts marked with () can be supplied separately or as part of a kit.*

All parts marked with (#) cannot be supplied separately.

Table 9. Variants depending on pump size

Size	Pos.5	Pos.3	Pos.3.1	Pos.11	Pos.11.1
Pump 54" NPU-04002	PU-04002-011	PU-04002-067	PU-04002-066	PU-04002-031	PU-04002-032
Pump 46" NPU-04003	PU-04002-041	PU-04002-067	PU-04002-066	PU-04002-031	PU-04002-032
Pump 40" NPU-04006	PU-04002-041	PU-04002-084	PU-04002-085	PU-04002-087	PU-04002-088
Pump 38" NPU-04004	PU-04002-041	PU-04002-068	PU-04002-064	PU-04002-061	PU-04002-060

N.B.: *All pumps contain the same parts, except for that indicated in Table 9.*



Table 10. Pump Flange Unit

Adapter Unit POS.15	Body Adapter POS.15.1	PUMP	Minimal High of Tank (*)
PU-04002-069	PU-04002-065	PU-04002/5 (54")	858 mm
		PU-04003 (46")	655 mm
		PU-04006 (40")	574 mm
		PU-04004 (38")	450 mm
PU-04002-069A	PU-04002-065A	PU-04002/5 (54")	843 mm
		PU-04003 (46")	640 mm
		PU-04006 (40")	559 mm
		PU-04004 (38")	434 mm
PU-04002-069B	PU-04002-065B	PU-04002/5 (54")	793 mm
		PU-04003 (46")	590 mm
		PU-04006 (40")	509 mm
		PU-04004 (38")	384 mm
PU-04002-069C	PU-04002-065C	PU-04002/5 (54")	748 mm
		PU-04003 (46")	545 mm
		PU-04006 (40")	464 mm
		PU-04004 (38")	339 mm
PU-04002-069D	PU-04002-065D	PU-04002/5 (54")	688 mm
		PU-04003 (46")	485 mm
		PU-04006 (40")	404 mm
		PU-04004 (38")	279 mm

N.B.:

Both for the 54" pump and for the 46", 40" and 38" Pumps, the adapter supplied as standard is the PU-04002-069. For the rest of the models, consult the delivery time with the Marketing department.

() The dimensions of the tank can change ± 5 mm*

**Table 11. KT-00097 (Pneumatic Plunger Seal Kit)**

Pos.	Description	Reference	Qty.
21.2	O-ring (*)	OR-00108	3
21.4	O-ring (*)	OR-00109	1
21.6	O-ring (*)	OR-00110	1
21.10	O-ring (*)	OR-00111	1
21.11	Plunger Guide (*)	PU-04002-026	1

Table 12. KT-00098 (Upper Stop Valve Kit)

Pos.	Description	Reference	Qty.
22	Lip Seal (*)	PU-04002-013	1
24	Stop Valve Segment (*)	PU-04002-015	3

Table 13. KT-00099 (Pump Lower Plunger Kit)

Pos.	Description	Reference	Qty.
7	Pump Lower Plunger Guide (*)	PU04000-067	1
8	Lower Plunger U-Cup Seal (*)	PU-04000-070	1

Table 14. KT-00100 (Pump Upper Plunger Kit)

Pos.	Description	Reference	Qty.
11.4	O-ring (*)	OR-00114	1
12	Pump Upper Plunger Lip Seal (*)	PU-04000-069	1

**Table 15. KT-00101 (Transfer Pump Seal Complete Kit)**

Pos.	Description	Reference	Qty.
1.4 (10)	O-ring (*)	OR-00107	2
15.2	Pump Base seal (*)	PU-04000-040	1
3.3	O-ring (*)	OR-00150	1
4	O-ring (*)	OR-00009	1
7	Pump Lower Plunger Guide (*)	PU04000-067	1
8	Lower Plunger U-Cup Seal (*)	PU-04000-070	1
11.4	O-ring (*)	OR-00114	1
12	Pump Upper Plunger Lip Seal (*)	PU-04000-069	1
17	Test Seat Seal	PU-04000-068	1
21.2	O-ring (*)	OR-00108	3
21.4	O-ring (*)	OR-00109	1
21.6	O-ring (*)	OR-00110	1
21.10	O-ring (*)	OR-00111	1
21.11	Plunger Guide (*)	PU-04002-026	1
22	Lip Seal (*)	PU-04002-013	1
24	Stop Valve Segment (*)	PU-04002-015	3
28	O-ring (*)	OR-00112	1
29	Cylinder Base Seal (*)	PU-04000-081	2
33	O-ring (*)	OR-00113	1
39	Air Purge Bolt Seal (*)	PU-04000-077	1

Table 16. List of Complements

Description	Reference	Qty.
Tin of Grease 397 g	BI-00008	1
Tin of Grease 49 g	BI-00009	1
Teflon Sealing Paste 50 ml	BI-00016	1



ASPIRATION VALVE PROLONGED (OPTIONAL)

A supplement prolonged 120mm valve pump 54 "with a length of 960 mm is available.

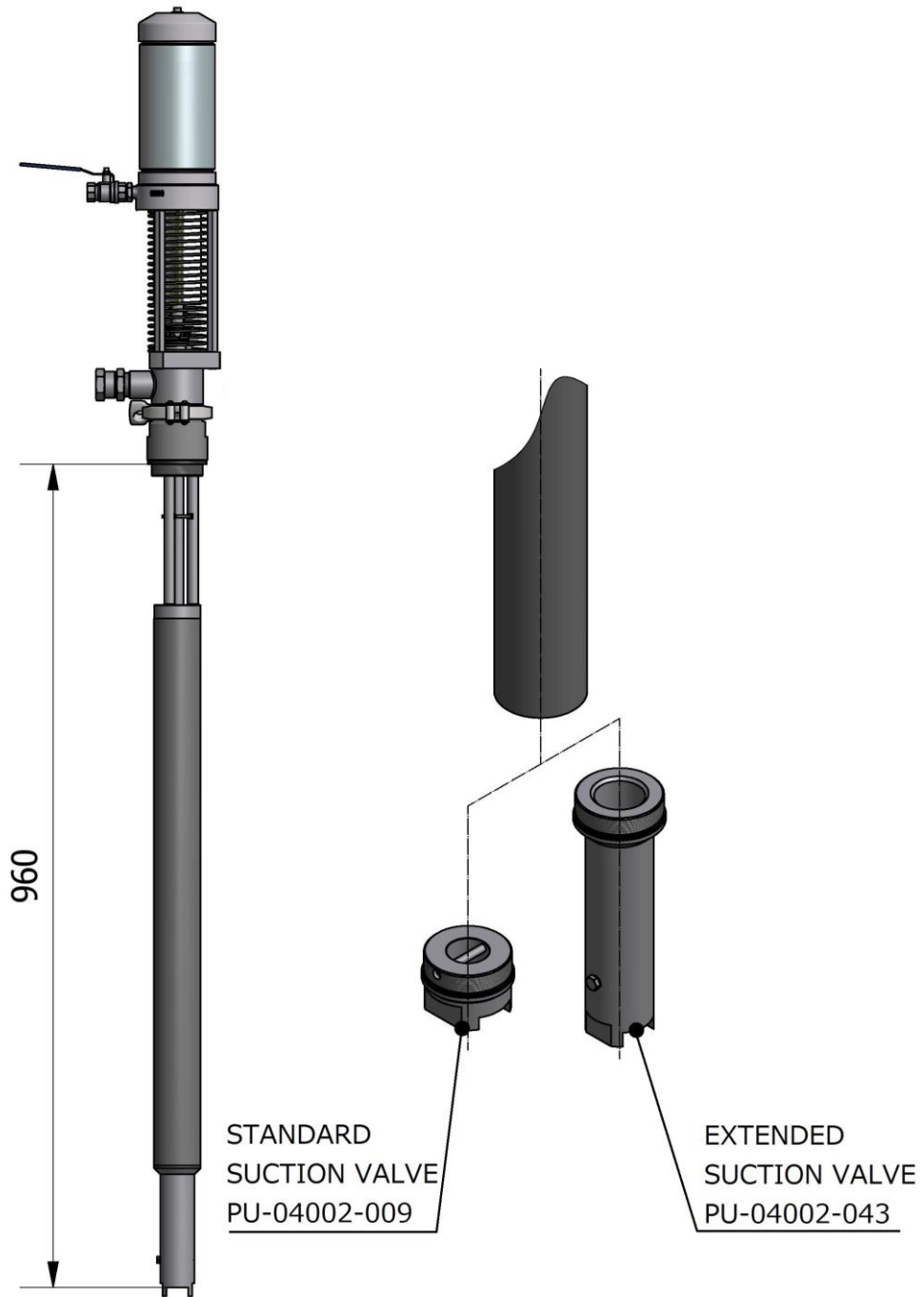
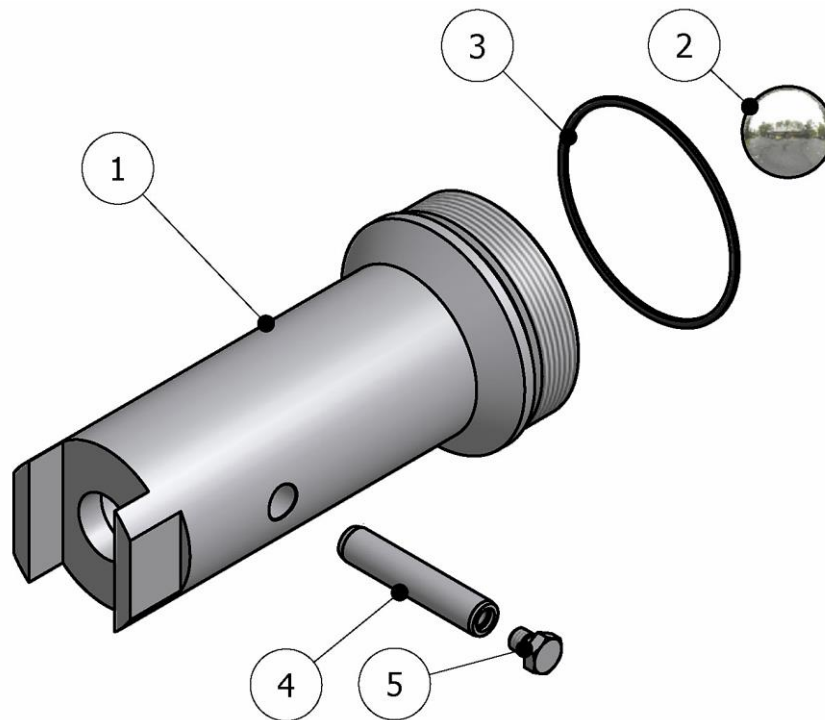

Figure 7. Assembly On 54" Standard Pump.



COMPONENTS OF ASPIRATION VALVE PROLONGED (OPTIONAL)



PU-04002-043

Figure 8. Detail Aspiration Valve Prolonged.

Table 17. Components Aspiration Valve Prolonged, Parts List.

Item.	Description	Part Number	Qty.
1	Aspiration Valve Body	PU-04002-044	1
2	Ball	PU-04000-090	1
3	O-Ring	OR-00107	1
4	Pin	TN-00390	1
5	Hex. Screw	TN-00391	1



54" PUMP WITH FLEXIBLE EXTENSION

To work in spaces with reduced heights, Hi-Tech offers a pump design with a flexible termination (NPU-04005), in order to be able to insert and extract this element in height restricted spaces.

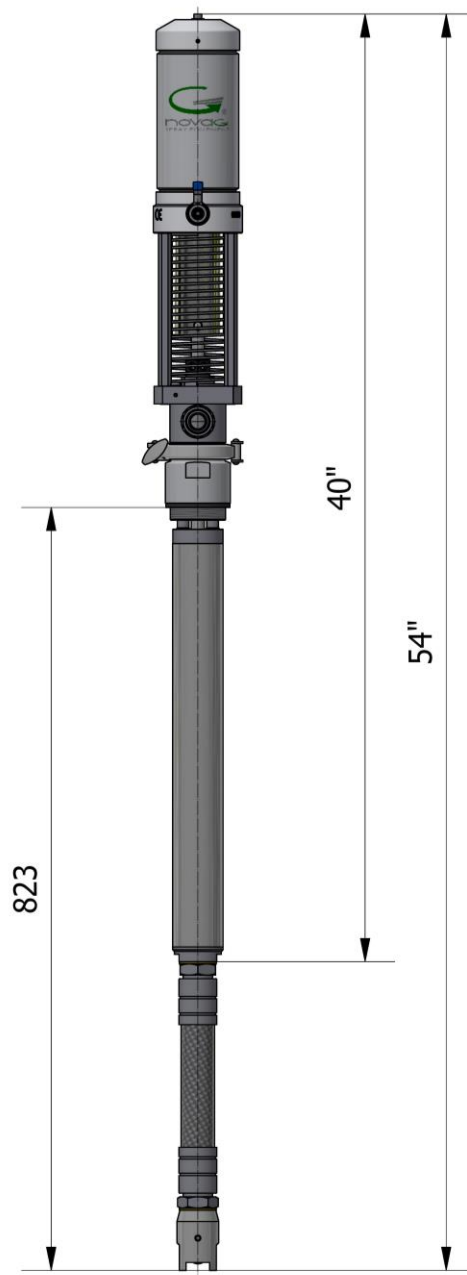
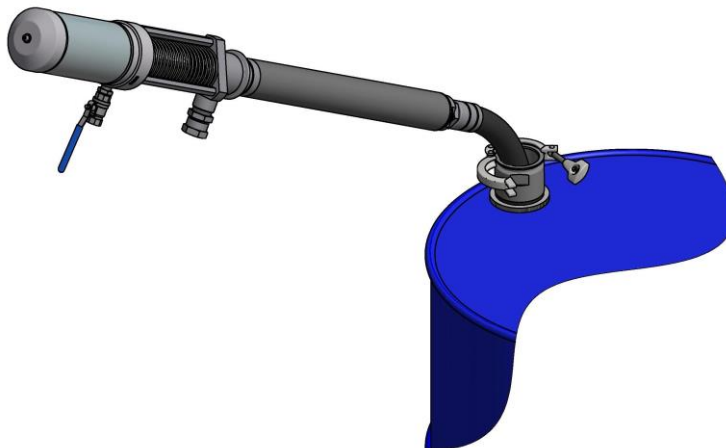
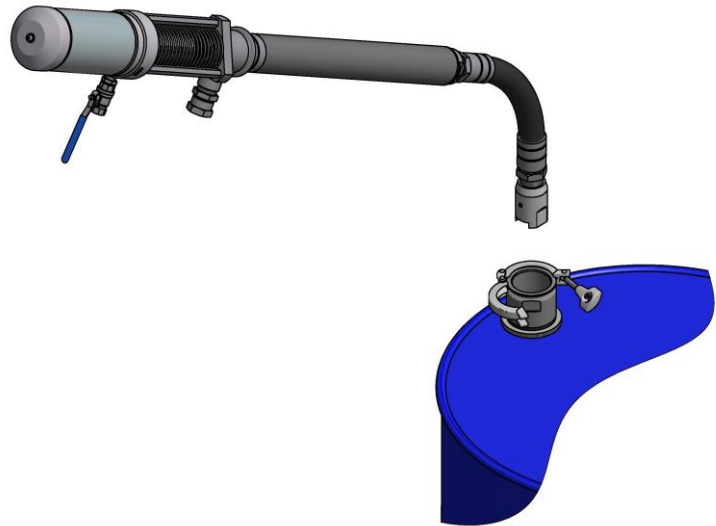

Figure 9. Pump dimensions 54" with flexible extension.



54" pump installation method with flexible extension

- a) Thread the transfer pump adapter into the drum. Make sure that it includes the gasket and the corresponding flange.
- b) Approach the transfer pump as vertically as the ceiling allows.
- c) Insert the suction tip into the tank adapter.
- d) Progressively move the pump. As it enters the tank, straighten the pump until it is in a vertical position and finish inserting it into the tank.
- e) Finally, secure it by closing the fastening flange.



NOTE: To remove the pump from the tank, follow the reverse procedure.



Exploded view of pump 54" with flexible extension

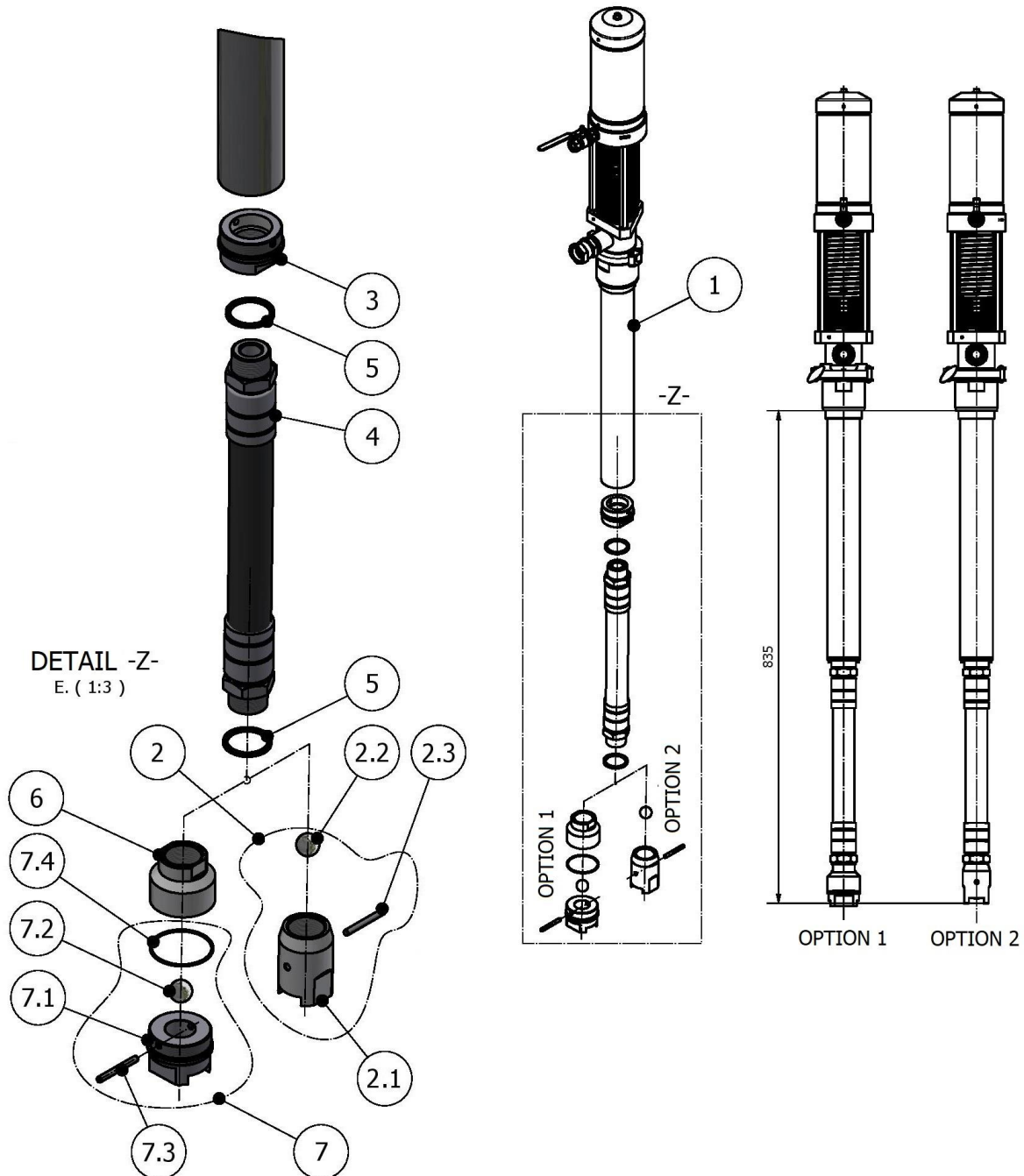

Option 1; For mounting as an extension accessory for existing pumps, from item 3 to item 6.

Option 2; For factory assembly as complete pump assembly NPU-04005, from item 1 (excluding item 7 PU-04002-009) to item 5.

Figure 10. Generic Explosion pump 54" with flexible extension.



Table 18. List of components 54" pump with flexible extension

item	Description	Reference	Qty.
1	40" pump assembly (except PU-04002-009)	PU-04006	1
2	Suction Valve Assy	PU-04002-083	1
2.1	Body Valve	PU-04002-082	1
2.2	Ball 3/4"	PU-04000-090	1
2.3	Dowel Pin	TN-00308	1
3	Adapter	PU-04002-050B	1
4	Hose	MA-00222	1
5	Metal O-Ring	OR-00061	2
6	Adapter (Option 2 Assy)	PU-04002-063	1
7	Suction Valve Assy (Option 1 Assy)	PU-04002-009	1
7.1	Body Valve (Included in item 7)	PU-04002-010	1
7.2	Ball Valve (Included in item 7)	PU-04000-090	1
7.3	Pin (Included in item 7)	TN-00308	1
7.4	O-Ring (included in item 7)	OR-00107	1

Option 1 (see page 40); For mounting as an extension accessory for existing pumps, from item 3 to item 6.

Option 2 (see page 40); For factory assembly as complete pump assembly NPU-04005, from item 1 (excluding item 7 PU-04002-009) to item 5.



CONTENT

Guarantee	2
Safety and Handling	3
Typical Installation	6
Description	7
Operation Diagram	8
Pneumatic Motor Operation	9
Pumping Mechanism Operation	9
Technical Specifications	10
Kits List of Transfer Pumps	11
Transfer Pumps Kits	12
Installation	17
Stopping method	20
Cleaning	20
Dismantling and Maintenance	22
troubleshooting	26
Method of Threaded Union of the Hoses	27
Component Identification	28
Aspiration Valve Prolonged (Optional)	36
Components of Aspiration Valve Prolonged (Optional)	37
54" PUMP WITH FLEXIBLE EXTENSION	38
<i>54" pump installation method with flexible extension</i>	39
<i>Exploded view of pump 54" with flexible extension</i>	40
Content	42
Illustrations List	43
List of Tables	44



ILLUSTRATIONS LIST

Figure 1. Typical Installation in a hydraulic unit with recirculation.	6
Figure 2. Operation Diagram	8
Figure 3. General Dimensions	10
Figure 4. General Diagram.	28
Figure 5. Details of Diagram of Upper Plunger (Pneumatic).	29
Figure 6. Details of Diagram of Lower Plunger.	29
Figure 7. Assembly On 54" Standard Pump.	36
Figure 8. Detail Aspiration Valve Prolonged.	37
Figure 9. Pump dimensions 54" with flexible extension.	38
Figure 10. Generic Explosion pump 54" with flexible extension.	40



LIST OF TABLES

Table 1. Kits List of Transfer Pumps _____	11
Table 2. Transfer Pump Kit NE-00072, Parts List _____	12
Table 3. Transfer Pump Kit NE-00072-01, Parts List _____	13
Table 4. Transfer Pump Kit NE-00080, Parts List _____	14
Table 5. Transfer Pump Kit NE-00073, Parts List _____	15
Table 6. Transfer Pump Kit NE-, Parts List _____	16
Table 7. Tightening Threaded Joints _____	27
Table 8. List of Components _____	30
Table 9. Variants depending on pump size _____	32
Table 10. Pump Flange Unit _____	33
Table 11. KT-00097 (Pneumatic Plunger Seal Kit) _____	34
Table 12. KT-00098 (Upper Stop Valve Kit) _____	34
Table 13. KT-00099 (Pump Lower Plunger Kit) _____	34
Table 14. KT-00100 (Pump Upper Plunger Kit) _____	34
Table 15. KT-00101 (Transfer Pump Seal Complete Kit) _____	35
Table 16. List of Complements _____	35
Table 17. Components Aspiration Valve Prolonged, Parts List. _____	37
Table 18. List of components 54" pump with flexible extension _____	41