



Parts Manual

Proportioning Unit

novaG III PLUS

Issue 2.5 - 01/09/2020
Ref. NR-00003-ENG



Before installing the unit and starting it up, carefully read all the technical and safety documentation included in this manual. Pay special attention to the information to know and understand the handling and the conditions of use of the unit. All of the information is aimed at enhancing User Safety and avoiding possible breakdowns derived from the incorrect use of the unit.



WARRANTY

HI-TECH SPRAY EQUIPMENT (hereinafter "HI-TECH") provides this **LIMITED WARRANTY** (hereinafter "Warranty") to the original purchaser (hereinafter "Customer") covering this equipment and the original HI-TECH manufactured accessories delivered with the equipment (hereinafter "Product") against defects in material or workmanship of the Product (hereinafter "Defect" or "Defective") for a period of two (2) years from the date of first purchase as shown on the original HI-TECH invoice (hereinafter "Warranty Period").

If during the Warranty Period under normal use, the Product is suspected by Customer to be Defective in material or workmanship, it is Customer's responsibility to contact HI-TECH and return the Product to HI-TECH as directed by HI-TECH, freight prepaid. If HI-TECH determines that the Product is Defective and that such Defect is covered by this Warranty, HI-TECH will credit Customer for the reasonable freight charges incurred by Customer in returning the Defective Product to HI-TECH, and HI-TECH (or its authorized agent) will, at HI-TECH's option, repair or replace the Product, subject to the following:

Original Invoice: The original invoice must be kept as proof of the date of first sale and the Product serial number. The Warranty does not cover any Product if the Original Invoice appears to have been modified or altered, or when the serial number on the Product appears to have been altered or defaced.

Product Maintenance: It is the Customer's responsibility to maintain the Product properly. See your maintenance schedule and owner's manual for details. The Warranty does not cover an improperly maintained Product.

Non-HI-TECH Components and Accessories: Non-HI-TECH manufactured components and accessories that are used in the operation of the Product are not covered by this Warranty. Such components and accessories shall be subject to the warranty offered to the Customer, if any, by the original manufacturer of such component or accessory.

Other Warranty Exclusions: The Warranty does not cover any Product that HI-TECH determines has been damaged or fails to operate properly due to misuse, negligence, abuse, carelessness, neglect, or accident. By way of example only, this includes:

- Normal wear and tear.
- Improper or unauthorized installation, repair, alteration, adjustment or modification of the Product.
- Use of heating devices, pumping equipment, dispensers, or other parts or accessories with the Product that have not been approved or manufactured by HI-TECH.
- Failure to follow the operating instructions and recommendations provided by HI-TECH.
- Cosmetic damage.
- Fire, flood, "acts of God," or other contingencies beyond the control of HI-TECH.

THE WARRANTY DESCRIBED HEREIN IS THE EXCLUSIVE REMEDY FOR THE CUSTOMER AND IS IN LIEU OF ALL OTHER WARRANTIES, EXPRESS, IMPLIED, STATUTORY OR OTHERWISE, AND THE IMPLIED WARRANTIES OF MERCHANTABILITY AND FITNESS FOR A PARTICULAR PURPOSE AND ALL OTHER WARRANTIES ARE HEREBY DISCLAIMED. TO THE FULLEST EXTENT PERMITTED BY LAW, HI-TECH SHALL NOT BE RESPONSIBLE, WHETHER BASED IN CONTRACT, TORT (INCLUDING, WITHOUT LIMITATION, NEGLIGENCE), WARRANTY OR ANY OTHER LEGAL OR EQUITABLE GROUNDS, FOR ANY CONSEQUENTIAL, INDIRECT, INCIDENTAL, LOST PROFITS, SPECIAL, PUNITIVE OR EXEMPLARY DAMAGES, WHETHER TO PERSON OR PROPERTY, ARISING FROM OR RELATING TO THE PRODUCT, EVEN IF HI-TECH HAS BEEN ADVISED OF THE POSSIBILITY OF SUCH LOSSES OR DAMAGES.

Non-Warranty Service by HI-TECH: If HI-TECH determines that the suspected Defect of the Product is not covered by this Warranty, disposition of the Product will be made pursuant to the terms and conditions of HI-TECH's written estimate on a time and materials basis.

Continuing Warranty for Products Repaired or Replaced under Warranty: Following the repair or replacement of a Product covered by this Warranty, such Product will continue to be subject to the original Warranty for the remainder of original Warranty Period or for three (3) months from the repair or replacement date, whichever is longer.

No Rights Implied: Nothing in the sale, lease or rental of any Product by HI-TECH shall be construed to grant any right, interest or license in or under any patent, trademark, copyright, trade secret or other proprietary right or material owned by anyone; nor does HI-TECH encourage the infringement of same.

Exclusive Warranty: This writing is the final, complete, and exclusive expression of the Warranty covering the Product. Any statements made by HI-TECH, its employees or agents that differ from the terms of this Warranty shall have no effect. It is expressly understood that Customer's acceptance of this Warranty, by performance or otherwise, is upon and subject solely to the terms and conditions hereof, and any additional or different terms and conditions proposed or expressed by Customer or anyone, whether in writing or otherwise, are null and void unless specifically agreed to in writing by an Officer of HI-TECH.



PROPORTIONING UNIT NOVAG III PLUS MODEL

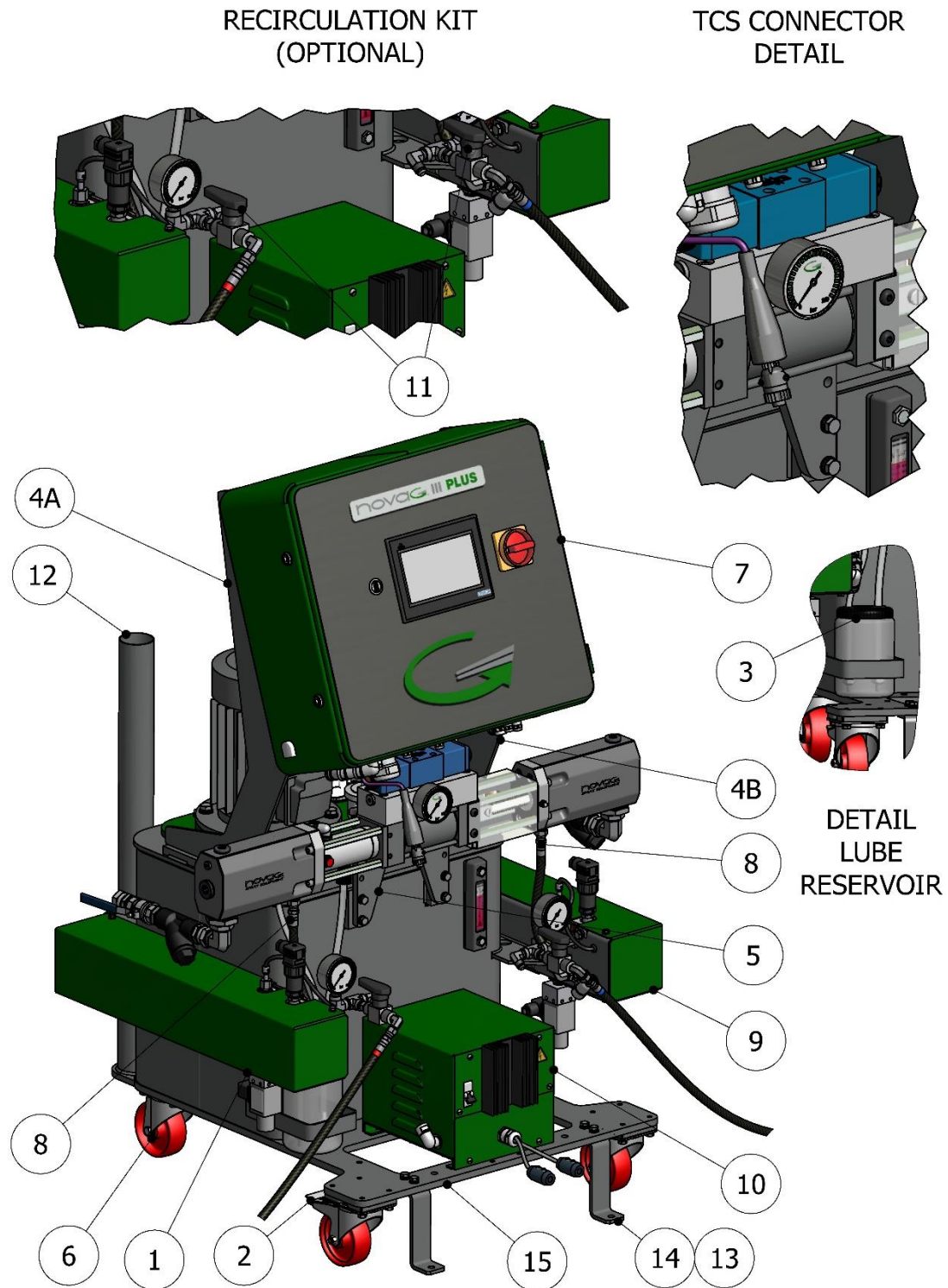

Figure 1. Proportioning Unit novaG III PLUS Model



Table 1. Proportioning Unit novaG III PLUS Model, Parts List

Item	Description	Part Number	Qty.
1	A Primary Heater	See Table 3	1
2	Front Wheel With Brake	MQ-01002	2
3	Lube Reservoir	MQ-01009-01	1
4A	Electrical Console LH Support	MQ-03003-00	1
4B	Electrical Console RH Support	MQ-03004-00	1
5	Pump Line Support	MQ-03000-00	1
6	Back Wheel	MQ-01016	2
7	Electrical Console Assy.	See Table 5	1
8	Hose Pump/Heater	MA-00180	2
9	R Primary Heater	See Table 4	1
10	Hose Transformer	See Table 2	1
11	Recirculation KIT (optional)	KT-00038	1
12	Transfer Pump Bracket (optional)	NMQ-01015-00	2
13	“Z” Bracket without Transfer Pump Bracket (optional)	NMQ-01017	2
14	“Z” Bracket with Transfer Pump Bracket (optional)	NMQ-02014	2
15	Plate	MQ-01001-05	1

Table 2. Hose Transformer Reference List

Part Number	Description
NEL-00127-24	Hose Transformer 3PE~400V Version
NEL-00127-23	Hose Transformer 3PE~230V Version



Table 3. A-Primary Heater Reference List

Part Number		Description
NCL-03101-00GT	400V	A Heater 6000 W with Transducer for 200 bar (standard)
NCL-03101-00IT		A Heater 5000 W with Transducer for 200 bar (optional)
NCL-03101-00HT		A Heater 6000 W with Transducer for 300 bar (optional)
NCL-03101-00BT	230V	A Heater 6000 W with Transducer for 200 bar (standard)
NCL-03101-00DT		A Heater 6000 W with Transducer for 300 bar (optional)

Table 4. R-Primary Heater Reference List

Part Number		Description
NCL-03102-00GT	400V	R Heater 6000 W with Transducer for 200 bar (standard)
NCL-03102-00IT		R Heater 5000 W with Transducer for 200 bar (optional)
NCL-03102-00HT		R Heater 6000 W with Transducer for 300 bar (optional)
NCL-03102-00BT	230V	R Heater 6000 W with Transducer for 200 bar (standard)
NCL-03102-00DT		R Heater 6000 W with Transducer for 300 bar (optional)

Table 5. Electrical Console Reference List

Part Number	Description
NEL-	Electrical Console Assy. (3PE~400V, with III phases Motor & Logger)
NEL-	Electrical Console Assy. (3PE~230V, with III phases Motor & Logger)



ELECTRICAL CONSOLE

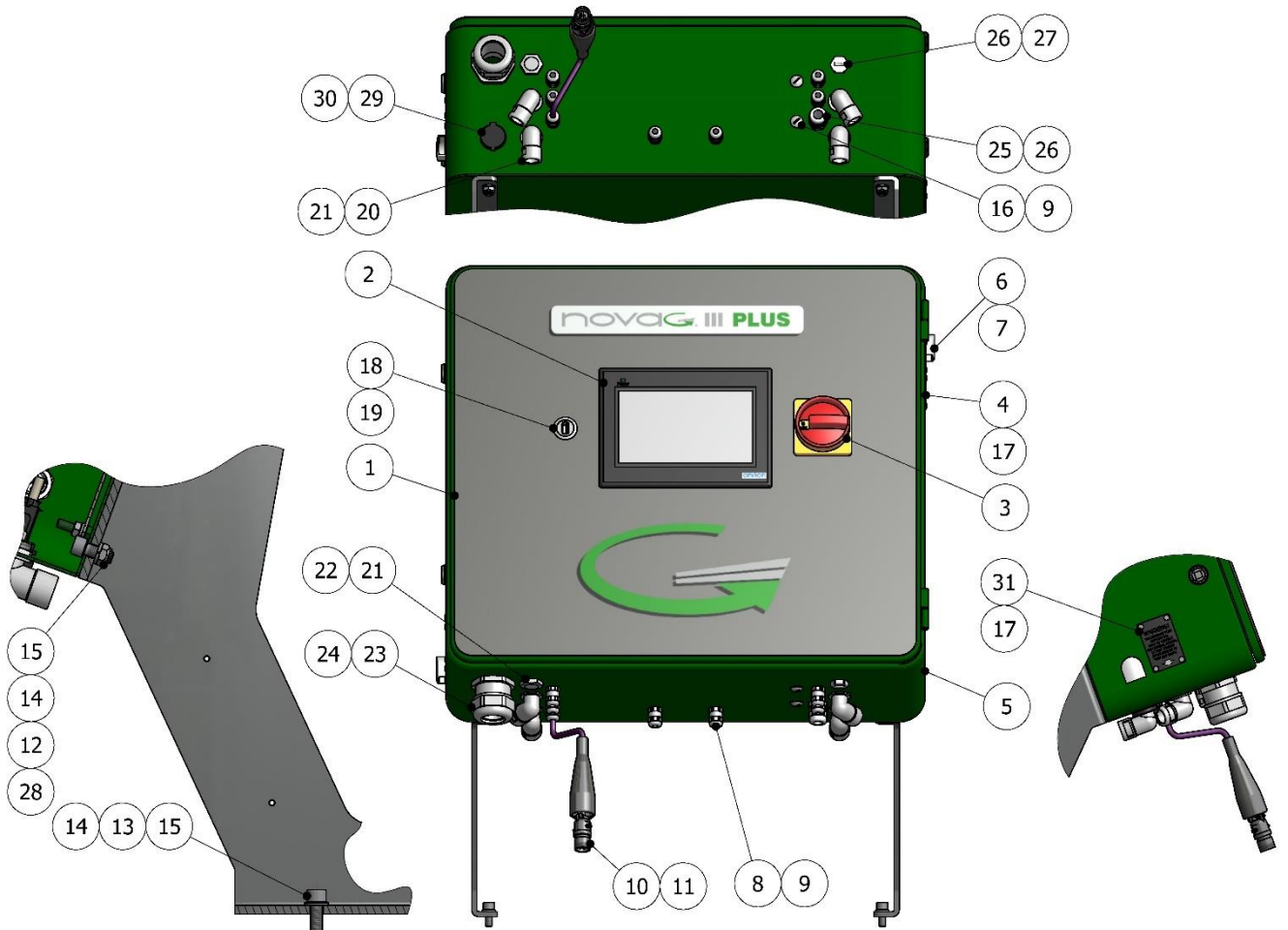

Figure 1. Electrical Console novaG III PLUS



Table 6. Electrical Console novaG III PLUS Model, Parts List

Item	Description	Part Number	Qty.
1	Bezel & Electronic Circuit	EL-00249-01	1
2	Touch Screen	EL-00171-02	1
3	Main Switch 3PE~400V version	EL-00107-07	1
	Main Switch 3PE~230V version	EL-00107-08	
3A	Command Switch (common for all versions)	EL-00107-06	1
4	Specs Plate	MQ-01010	1
5	Electrical Console	EL-00246	1
6,7	Air Vent with Nut	EL-00158-05	2
8	Connector	EL-00088-00	7
9	Nut	EL-00090-00	9
10	Connector Sensor Cover	EL-00096-21	1
11	Connector Sensor Male	EL-00096-19	1
12	Lock Nut	TN-00283	4
13	Washer	TN-00119	4
14	AET Washer	TN-00038	8
15	Screw	TN-00176	8
16	Plug	EL-00183	2
17	Rivet	TN-00240	8
18	USB Port	EL-00078-04	1
19	Mass. Storage 4 GB (#)	NEL-00078-05	1
20	Elbow	EL-00087-01	4
21	Nut	EL-00090-01	5
22	Plug	EL-00088-03	1
23	Connector	EL-00088-04	1
24	Nut	EL-00090-05	1
25	Connector	EL-00088-05	1
26	Nut	EL-00090-06	2
27	Plug	EL-00088-08	1
28	Lock Washer	TN-00028	4
29,30	Female Connector with Cap and Cable 0.5m with Nut	EL-00078-10	1
31	Warning Label	EM-00094	1

Notes: (#) Parts not show in draw.



HYDRAULIC MANIFOLD WITH MOTOR 3PE~400V/230V 50/60Hz (hyd. Pump 18 cc.)

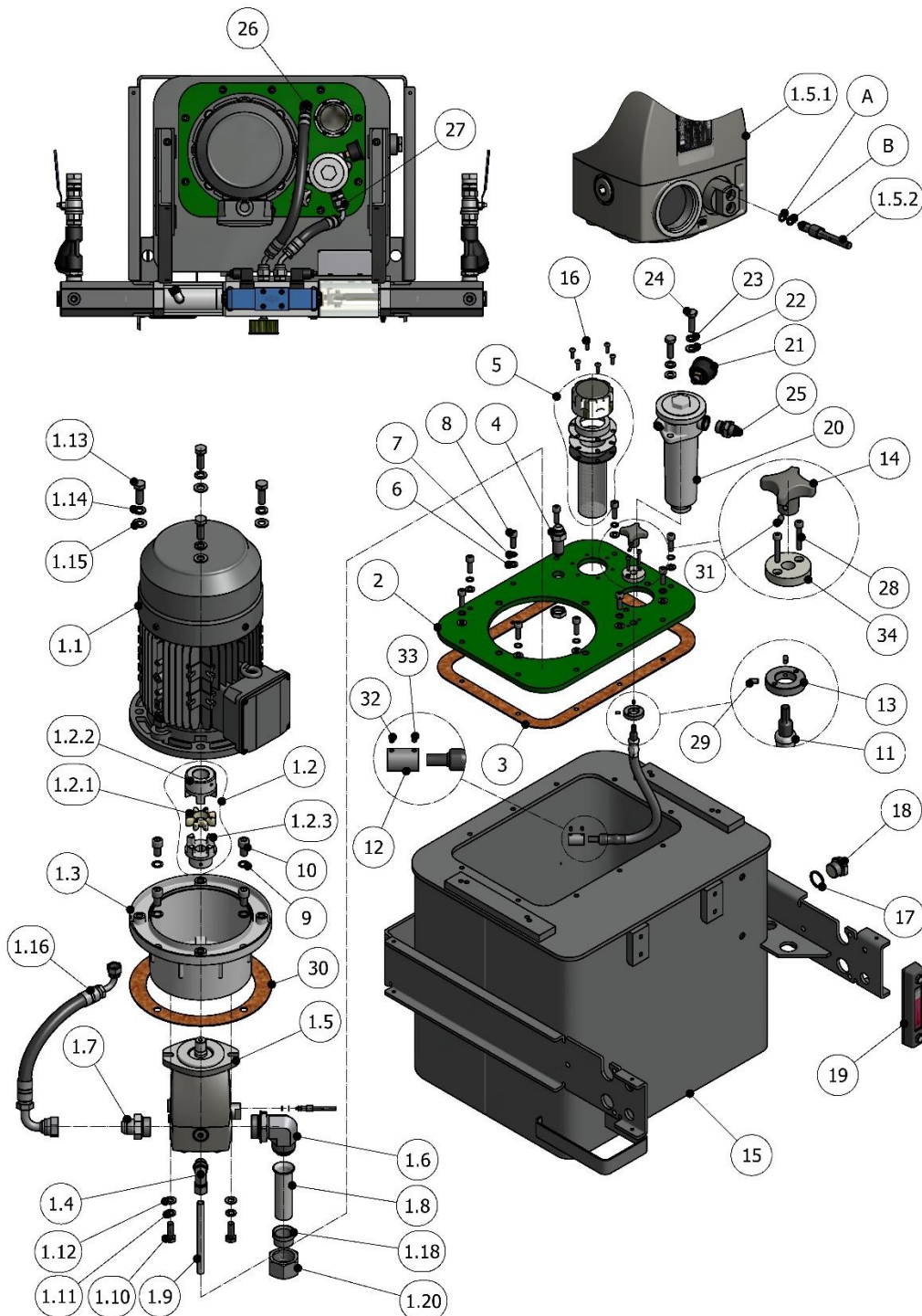

**Figure 2. Hydraulic Manifold 3PE~400V/230V 50/60Hz (hyd. Pump 18 cc),
Exploded View**



**HYDRAULIC MANIFOLD WITH MOTOR 3PE~400V/230V
50/60Hz (hyd. Pump 20 cc.)**

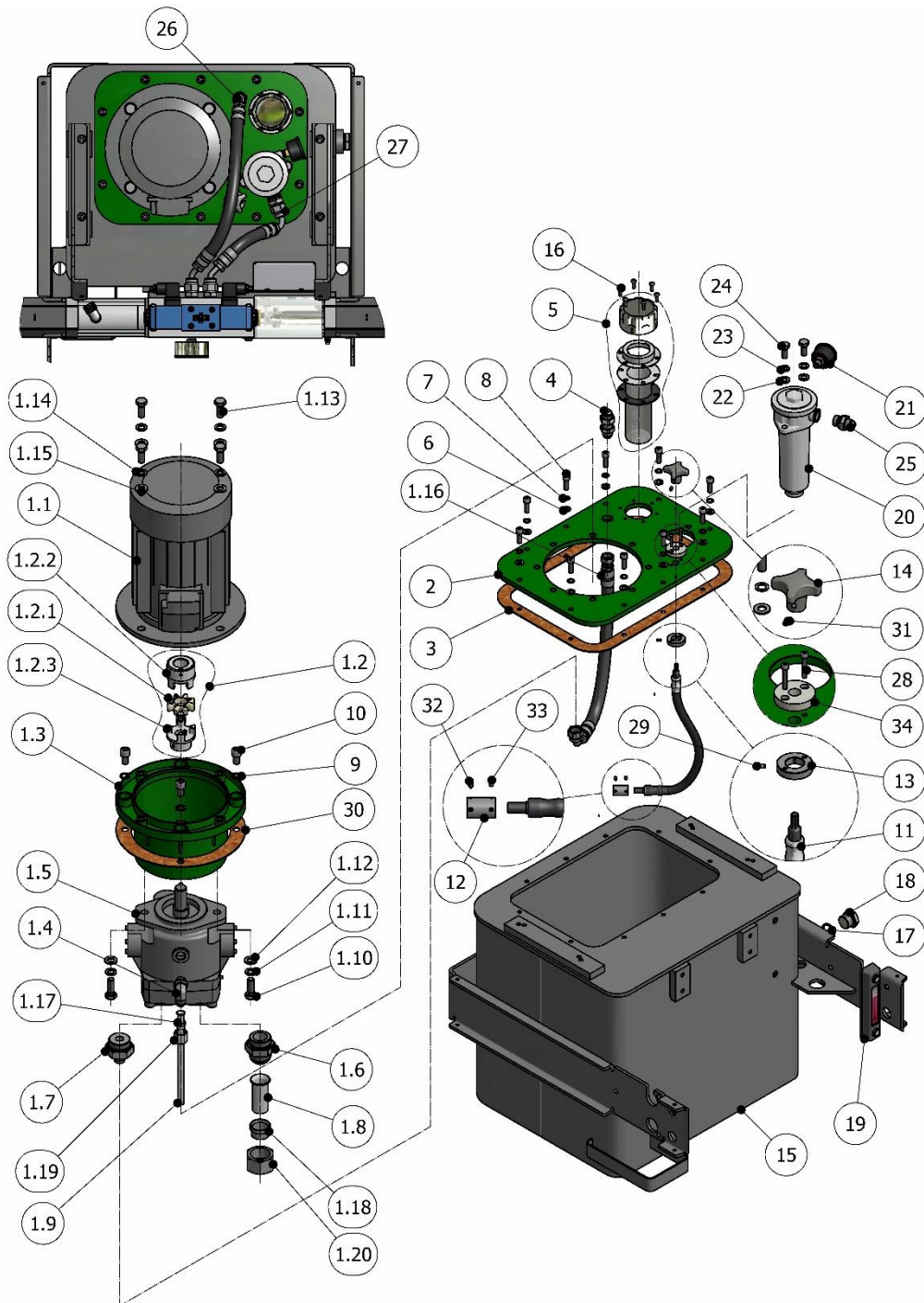

**Figure 3. Hydraulic Manifold 3PE~400V/230V 50/60Hz (hyd. Pump 20 cc),
Exploded View**



Table 7. Hydraulic Manifold with Motor 3PE~400V/230V 50/60Hz, Parts List

Item.	Description	Part Number	Qty.
1	Motor/Pump Line Assembly	-	1
1.1	Electric Motor 4kW 50/60Hz	NEL-00138-04	1
1.2	Coupler Assembly (18 cc)	HI-00046-00	1
	Coupler Assembly (20 cc)	HI-00006-00	
1.2.1	Alignment Spider (18 cc) & (20 cc)	HI-00006-01	1
1.2.2	Motor Shaft Coupling (18 cc) & (20 cc)	HI-00006-02	1
1.2.3	Pump Shaft Coupling (18 cc)	HI-00046-01	1
	Pump Shaft Coupling (20 cc)	HI-00006-03	
1.3	Bell Housing for 18 cc Pump	HI-00139-00	1
	Bell Housing for 20 cc Pump	HI-00005	
1.4	Elbow (18 cc)	RA-00494	1
	Elbow (20 cc)	-	
1.5	HYD Pump Assembly 18 cc. (items 1.5.1 & 1.5.2)	HI-00190-NIII	1
	HYD Pump Assembly 20 cc. (items 1.5.1 , 1.5.2 & 1.5.3)	HI-00038-NIII	
1.5.1	HYD Pump 18 cc (included in item 1.5)	HI-00190-00	1
	"A" Anti Extrusion Ring	OR-	1
	"B" O-Ring	OR	1
	HYD Pump 20 cc (included in item 1.5)	HI-00038-00	1
	O-Ring	OR-00025	1
1.5.2	18 cc Regulating rod (included in item 1.5)	HI-00149-01	1
	20 cc Regulating rod (included in item 1.5)	HI-00042	1
1.5.3	Stopper Nut (included in item 1.5), only for 20 cc	HI-00043	1
1.6	Elbow (18 cc)	RA-00027	1
	Ferrule (18 cc)	RA-00029	
	Nut (18 cc)	RA-00028	
	Nipple (20 cc)	-	
1.7	Nipple (18 cc)	RA-00500	1
	Nipple (20 cc)	RA-00069	
1.8	Suction Pipe (18 cc)	HI-00194	1
	Suction Pipe (20 cc)	-	



Item.	Description	Part Number	Qty.
1.9	Drain Pump Pipe (18 cc)	HI-00156	1
	Drain Pump Pipe (20 cc)	-	
1.10	Hex. Cap Screw (18 cc)	TN-00129	2
	Hex. Cap Screw (20 cc)	TN-00199	
1.11	Lock Washer (18 cc)	TN-00087	2
	Lock Washer (20 cc)	TN-00039	
1.12	Washer (18 cc)	TN-00162	2
	Washer (20 cc)	TN-00040	
1.13	Hex. Cap Screw	TN-00199	4
1.14	Lock Washer	TN-00039	4
1.15	Washer	TN-00040	4
1.16	Pressure Hose (18 cc)	HI-00157	1
	Pressure Hose (20 cc)		
1.17	Ferule (20 cc)	RA-00173	1
1.18	Ferule (18 cc - 20 cc)	RA-00029	1
1.19	Nut (20 cc)	RA-00174	1
1.20	Nut (18 cc - 20 cc)	RA-00028	1
2	Reservoir Cover Plate	HI-00163-00	1
3	Reservoir Cover Plate Gasket	HI-00164	1
4	Bulkhead Union	RA-00172	1
5	HYD-Oil Filler	HI-00002	1
6	Washer	TN-00119	10
7	Lock Washer	TN-00038	10
8	Screw	TN-00027	10
9	AET Washer	TN-00015	4
10	Screw	TN-00177	4
11	Flexible Extension	RA-00473	1
12	Coupler Extension to Pump	RA-00474	1
13	Support Extension to Cover	RA-00475	1
14	Handle	HI-00044-01	1
15	Hydraulic Tank	HI-00166-00	1
16	ULS Screw	TN-00166	6



Item.	Description	Part Number	Qty.
17	Metal O-Ring	OR-00082	1
18	Hex.Cap Plug	RA-00022	1
19	Thermometer and Fluid Level Gauge	HI-00001	1
20	Hydraulic Filter	HI-00123-00	1
21	Pressure Gauge (included in item 20)	HI-00123-03	1
22	Washer	TN-00162	2
23	Lock Washer	TN-00087	2
24	Hex. Cap Screw	TN-00163	2
25	Nipple	RA-00316	1
26	Hyd. Pressure Hose	HI-00158	1
27	Hyd. Return Hose	HI-00159	1
28	Allen Screw	TN-00117	2
29	Screw	TN-00436	2
30	Bell Gasket	HI-00160	1
31	Screw	TN-00437	1
32	Screw	TN-00099	2
33	Screw	TN-00246	2
34	Extension Guide	RA-00475-01	1



REVERSING SWITCH & PUMP LINE SUPPORT

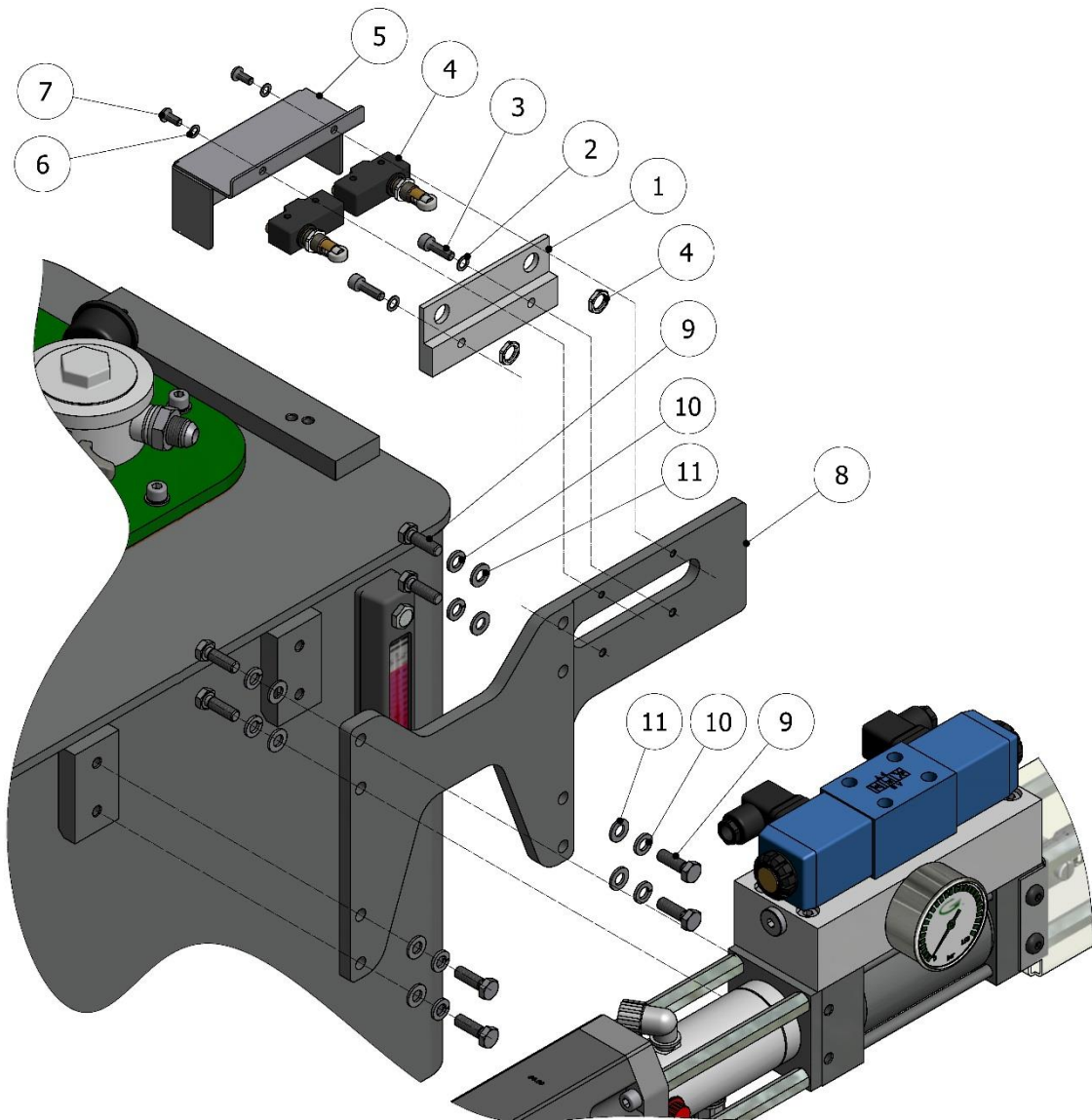

Figure 4. Reversing Switch & Pump Line Support, Exploded View



Table 8. Reversing Switch & Pump Line Support, Parts List

Item	Description	Part Number	Qty.
1	Reversing Switch Support	MQ-01005	1
2	AET Washer	TN-00048	2
3	Socket Head Cap Screw	TN-00026	2
4	Pump Reversing Switch (with 2 nuts)	EL-00020	2
5	Reversing Switch Cover	MQ-01006	1
6	AET Washer	TN-00017	2
7	ULS Screw	TN-00159	2
8	Pump Line Support	MQ-03000-00	1
9	Hex Head Cap Screw	TN-00146	4+4
10	Lock Washer	TN-00028	4+4
11	Washer	TN-00119	4+4



LUBE RESERVOIR HOSE ASSEMBLY

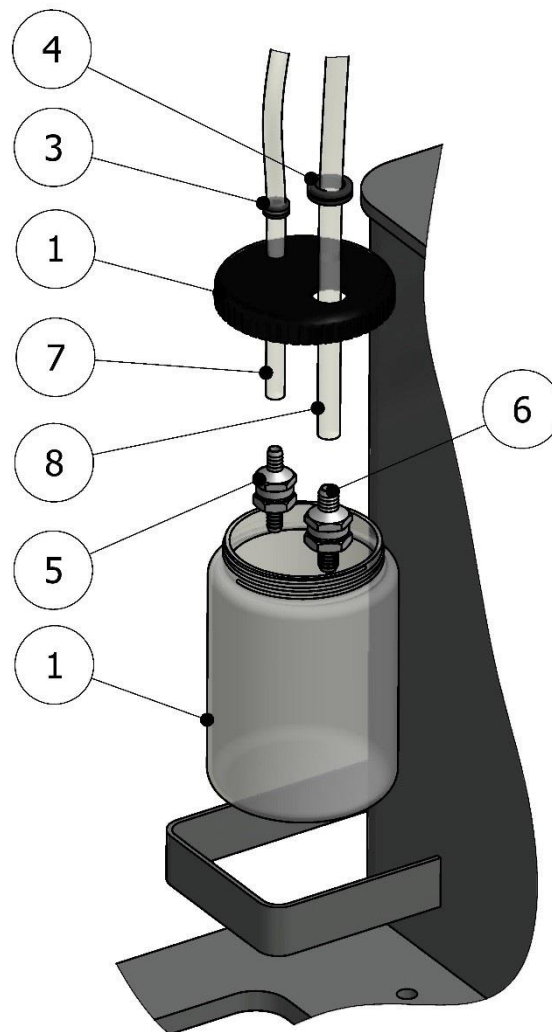

Figure 5. Lube Reservoir Hose Assembly, Exploded View



Table 9. Lube Reservoir Hose Assembly, Parts List

Item	Description	Part Number	Qty.
1	Lube Reservoir Bottle with Drilled Cap	MQ-01009-01	1
2			
3	Rubber Grommet	EL-00095-01	1
4	Rubber Grommet	EL-00095-03	1
5	Lube Reservoir Check Valve for Pipe 10x1	RA-00283	1
6	Lube Reservoir Check Valve for Pipe 12x1	RA-00068	1
7	Return Line	MA-00024	1
8	Supply Line	MA-00025	1



PUMP LINE ASSEMBLY

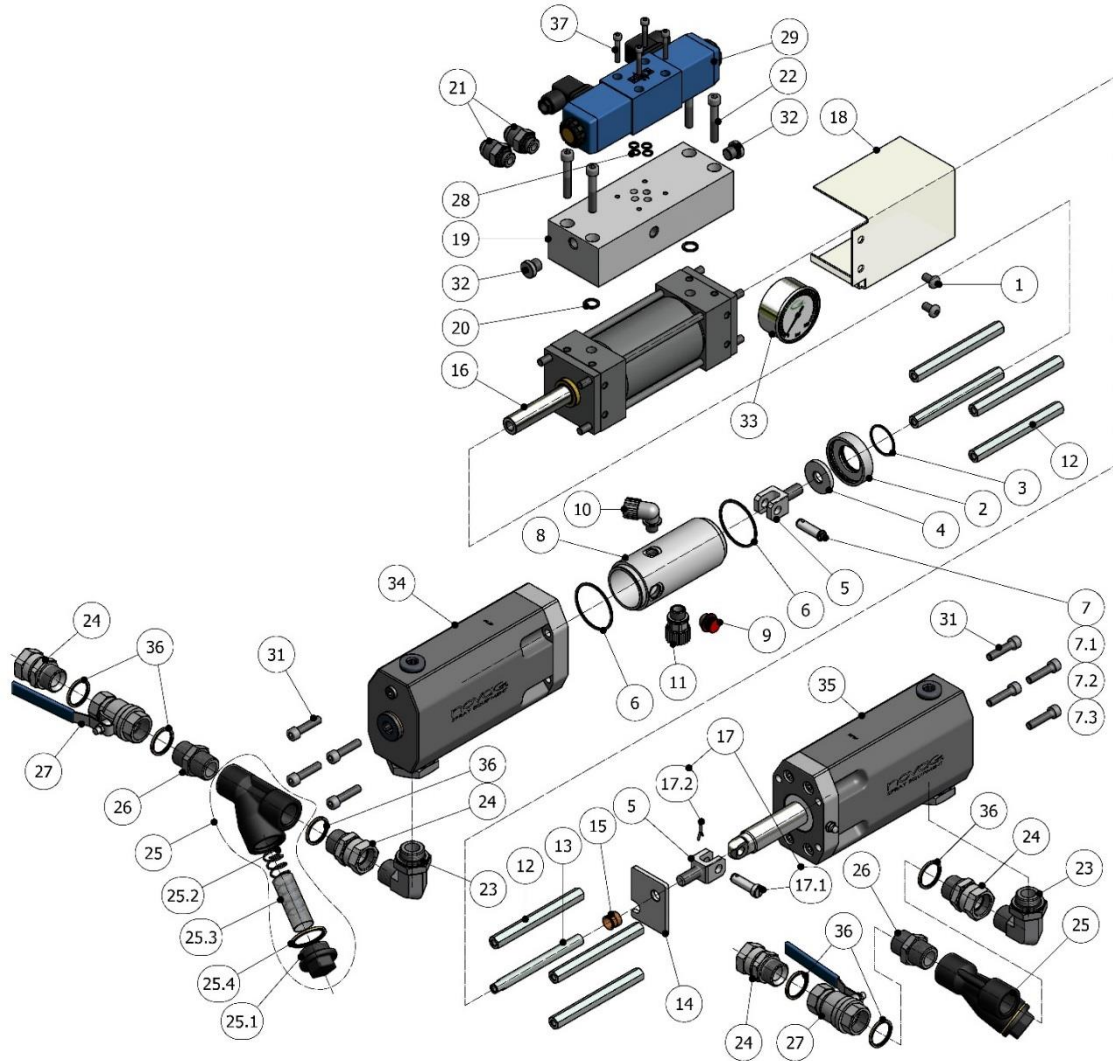

Figure 6. Pump Line Assembly, Exploded View



Table 10. Pump Line Assembly, Parts List

Item	Description	Part Number	Qty.
1	"ULS" Screw	TN-00135	2
2	Lube Cylinder Adapter Plate	PU-01021	1
3	O-Ring	OR-00021	1
4	Baffle	PU-01019	1
5	Hydraulic Cylinder Clevis	PU-01043	2
6	Lube Cylinder O-Ring	OR-00020	2
7	"A" Clevis Pin Assembly (Include item 7.1, 7.2 & 7.3)	PU-01044-00	1
7.1	Clevis Pin (included in item 7)	PU-01044-01M	1
7.2	Clevis Pin Clip (included in item 7)	TN-00136	1
7.3	Washer (included in item 7)	TN-00024	1
8	Lube Cylinder	PU-01018	1
9	Polyethylene Pipe Plug	RA-00116	1
10	Lube Cylinder Elbow	RA-00066	1
11	Lube Cylinder fitting	RA-00067	1
12	Proportioning Pump Spacer	PU-01025	7
13	Reversing Switch Pump Spacer	PU-01026	1
14	Reversing Switch Activate Plate	PU-01023	1
15	Bronze Bushing	PU-01022	1
16	Hydraulic Cylinder With Spacers	NHI-00101	1
17	"R" Clevis Pin Assembly (includes item 17.1 & 17.2)	PU-01045-00	1
17.1	"R" Clevis Pin	PU-01045-01	1
17.2	Pin	TN-00077	1
18	Activator Plate Cover	PU-01027	1
19	Hydraulic Manifold	MQ-01007	1
20	O-Ring	OR-00019	2
21	Hex nipple	RA-00062	2
22	Socket Head Cap Screw	TN-00090	4
23	Elbow	RA-00072	2
24	Swivel Union	RA-00073	4



Item	Description	Part Number	Qty.
25	Y-Strainer	RA-00074-00	2
25.1	Filter Plug	RA-00074-01	2
25.2	Filter Spring	SP-00017	2
25.3	Filter	RA-00074-03-30	2
25.4	Filter Gasket	OR-00061	2
26	Hex Nipple	RA-00143	2
27	Ball Valve	RA-00078	2
28	Junta Tórica	OR-00035	4
29	Directional valve	HI-00054	1
30			
31	Socket Head Cap Screw	TN-00245	8
32	Plug	RA-00013	2
33	Hydraulic Gauge	NHI-00078	1
34	"A" Proportioning Pump Assembly	See Table 11	1
35	"R" Proportioning Pump Assembly	See Table 11	1
36	Gasket	OR-00082	6
37	Screw	TN-00148	4

Table 11. Proportioning Pump Size, Parts

SIZE	Proportioning Pump Size	
	item 34 (ISO Pump)	item 35 (POL Pump)
1.20 (standard)	NPU-06101-012G	NPU-06102-012G
0.80 (optional)	NPU-06101-008G	NPU-06102-008G

Note: (*) The standard proportioning pump size is #1.20. Different sizes are available under order. For delivery time, please consult with marketing department.



HYDRAULIC CYLINDER WITH SPACERS

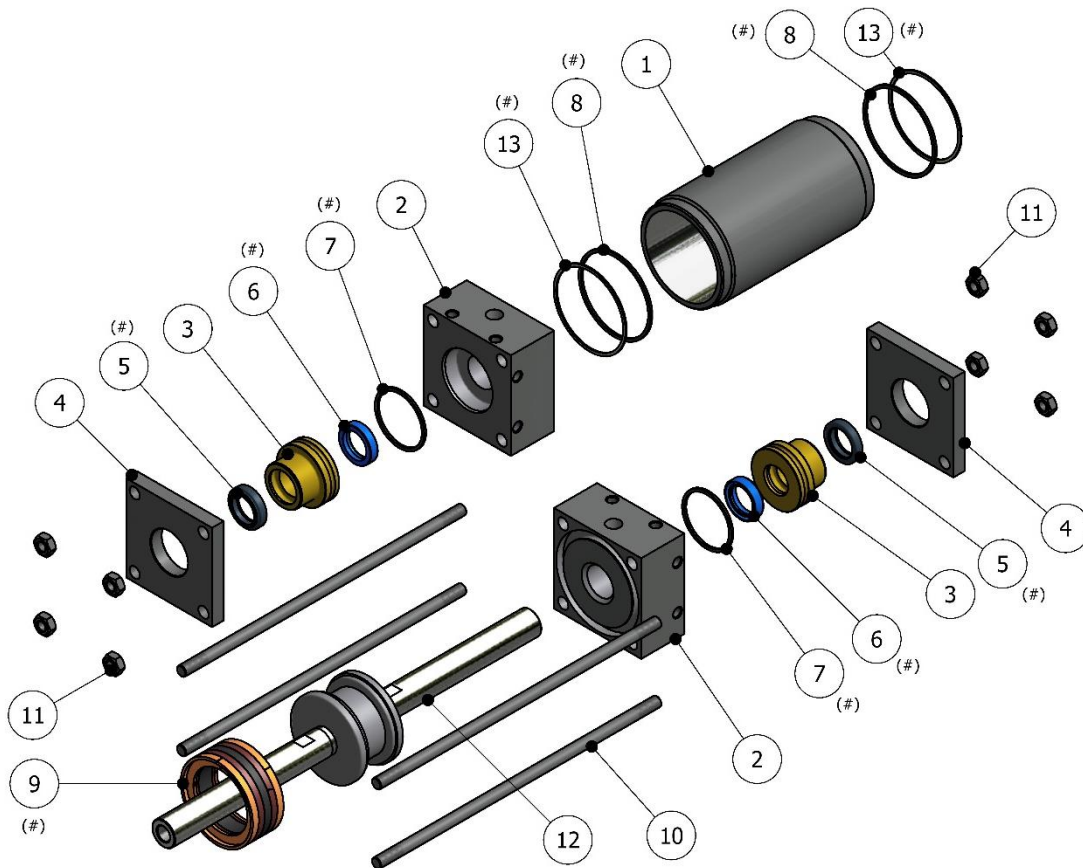

Figure 7. Hydraulic Cylinder with Spacers, Exploded View

N.B.: The indicated parts (#) are included in the repair seal kit KT-00010-01.



Table 12. Hydraulic Cylinder with Spacers, Parts List

Item	Description	Part Number	Qty.
1	Cylinder Body	NHI-00025-05	1
2	Port Block	NHI-00101-04	2
3	Rod Bushing	HI-00101-03	2
4	Front Plate	NHI-00025-02	2
5	Rod Wiper	OR-00095	2 (#)
6	Shaft Seal	OR-00096	2 (#)
7	O-Ring	OR-00039	2 (#)
8	O-Ring	OR-00040	2 (#)
9	Piston O-ring	OR-00041-00	1 (#)
10	Hydraulic Cylinder Tie Rod	NHI-00025-06	4
11	Nut (*)	TN-00029	8
12	Piston	HI-00101-01	1
13	O-Ring Anti Extrusion	OR-00063	2 (#)

() Only when the cylinder is supplied as a spare part. Not included in the Pump Line fitted in the machine.*

The indicated parts (#) are included in the repair seal kit KT-00010-01



“A” PROPORTIONING PUMP ASSEMBLY

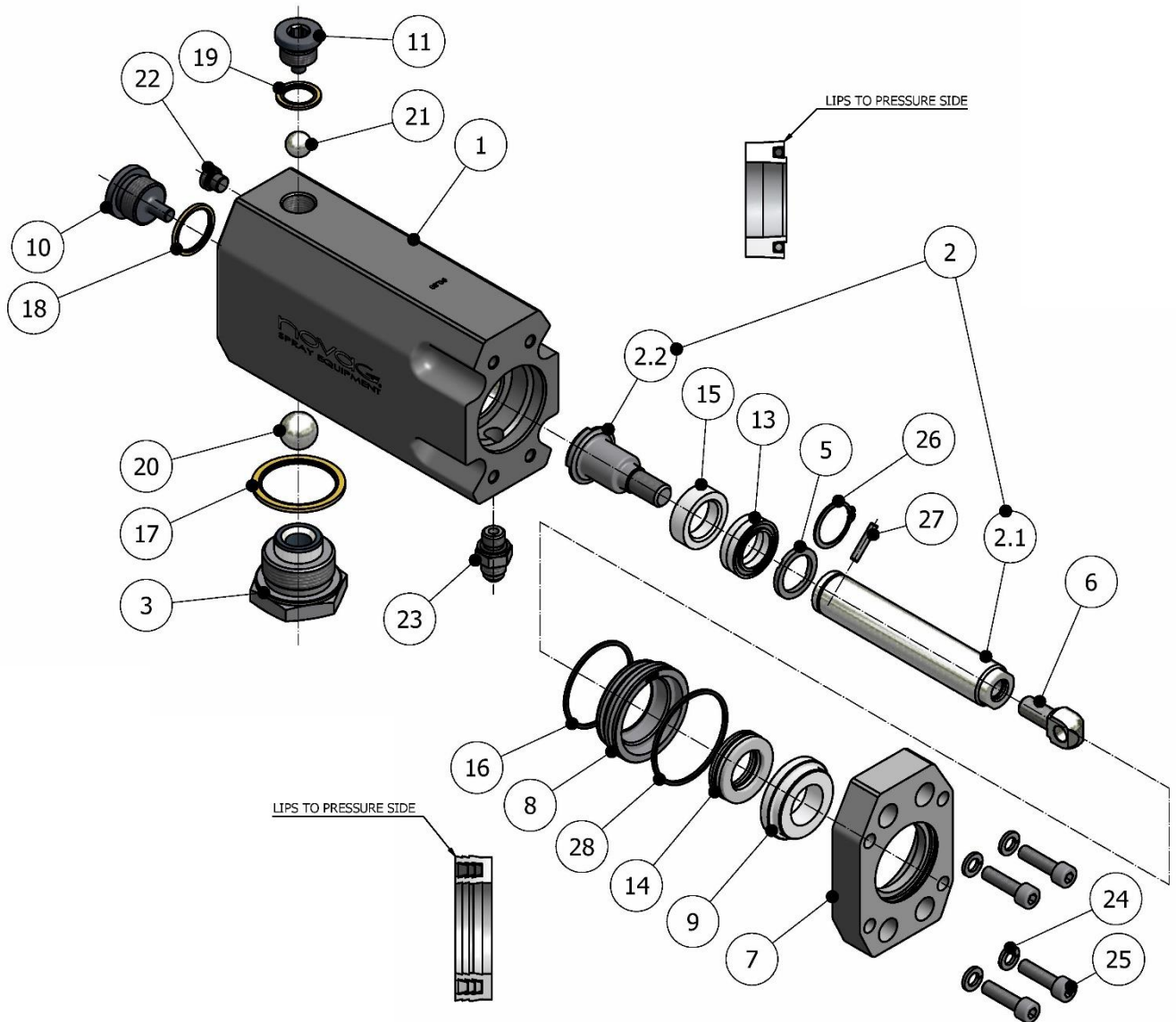

Figure 8. “A” Proportioning Pump Assembly, Exploded View

**Table 13. "A" Proportioning Pump Assembly, Parts List**

Item	Description	Part Number	Qty.
1	Body Pump with Check Valve Seat	See Table 14	1
2	Piston Rod Assembly (Only item. 2.1 y 2.2)	See Table 14	1
2.1	Piston Rod (Included in item 2)	See Table 14	1 (#)
2.2	Piston Head (Included in item 2)	See Table 14	1 (#)
3	Inlet Ball Seat Assembly	PU-01003-0J	1
4			
5	Piston Seal	See Table 14	1
6	Pump Clevis	PU-01042	1
7	Monobloc Flange Pump – ISO	NPU-06004	1
8	Seat Seal – ISO	See Table 14	1
9	Bearing ISO	See Table 15	1 (*)
10	Plug Side Pump	PU-01003-0E	1
11	Upper Plug Pump	PU-01003-0F	1
12			
13	Piston Seal	See Table 15	1 (*)
14	Cylinder Seal	See Table 15	1 (*)
15	Piston Guide	See Table 15	1 (*)
16	O-Ring	See Table 15	1 (*)
17	Metallic Ring	OR-00088	1
18	Metallic Ring	OR-00082	1
19	Metallic Ring	OR-00023	1
20	Lower Ball	TN-00013	1
21	Upper Ball	TN-00012	1
22	Plug	RA-00211	1
23	Output Elbow	RA-00145	1
24	Washer	TN-00028	4
25	Allen Screw	TN-00062	4
26	Seeger Ring	See Table 14	1
27	Pin	See Table 14	1
28	O-Ring	See Table 15	1 (*)

N.B.: The parts marked with (*), are included in the repair seal kit of "A" pump (see Table 16).

The parts marked with (#), are not supplied separately.



Table 14. "A" Proportioning Pump Assembly, Parts List

Pump	Item 1	Item 2 (2.1 + 2.2)	Item 2.1	Item 2.2
1.20 (#)	NPU-06001-012	PU-01006-012	PU-01007-012	PU-01008-012
0.80	NPU-06001-008	PU-01006-008	PU-01007-008	PU-01008-008

Pump	Item 5	Item 8	Item 26	Item 27
1.20 (#)	PU-01010-012	PU-06009-012G	TN-00070	TN-00086
0.80	PU-01010-008	PU-06009-008G	TN-00067	TN-00085

Table 15. Seals Monobloc "A" Pump

item	1.20 (#)	0.80
9	PU-06007-012	PU-06007-008
13	PU-01016-012A	PU-01016-008A
14	PU-01017-012G	PU-01017-008G
15	PU-01014-012A	PU-01014-008A
16	OR-00009	OR-00009
28	OR-00115	OR-00115

Table 16. Repair Seal Kit "A" Pump

Pump	Item
1.20 (#)	KT-00157
0.80	KT-00159

N.B :

(#) The standard proportioning pump sizes is #1.20. Different sizes are available under order. For delivery time, please consult with marketing department.

The Repair seal kit include the parts indicated (*) in the Table 13.



“R” PROPORTIONING PUMP ASSEMBLY

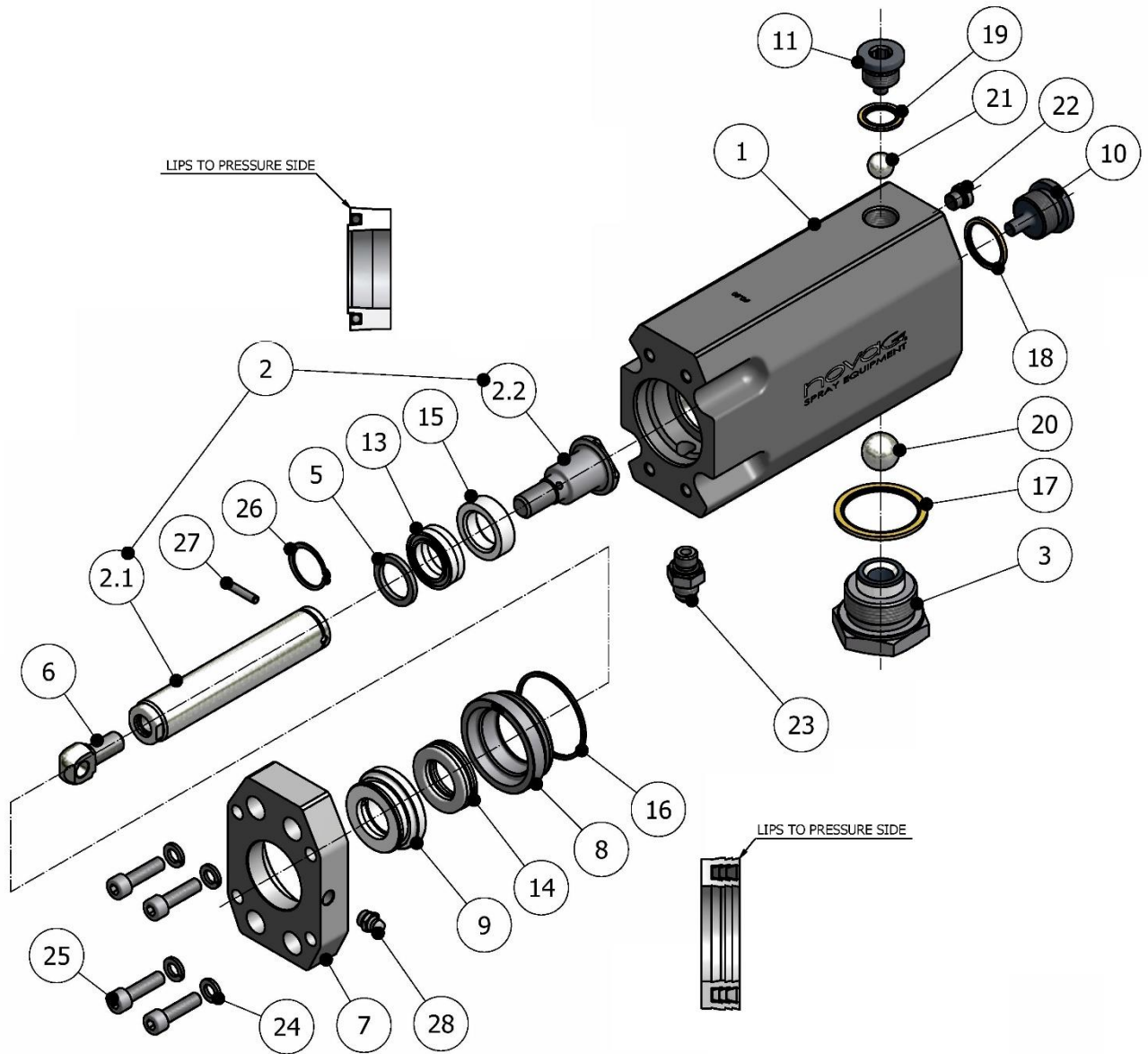

Figure 9. “R” Proportioning Pump Assembly, Exploded View



Table 17. “R” Proportioning Pump Assembly, Parts List

Item	Description	Part Number	Qty.
1	Body Pump with Check Valve Seat	See Table 18	1
2	Piston Rod Assembly (Only item. 2.1 y 2.2)	See Table 18	1
2.1	Piston Rod (Included in item 2)	See Table 18	1 (#)
2.2	Piston Head (Included in item 2)	See Table 18	1 (#)
3	Inlet Ball Seat Assembly	PU-01003-0J	1
4			
5	Piston Seal	See Table 18	1
6	Pump Clevis	PU-01042	1
7	Monobloc Flange Pump – POL	NPU-06005	1
8	Seat Seal – POL	See Table 18	1
9	Bearing ISO	See Table 19	1 (*)
10	Plug Side Pump	PU-01003-0E	1
11	Upper Plug Pump	PU-01003-0F	1
12			
13	Piston Seal	See Table 19	1 (*)
14	Cylinder Seal	See Table 19	1 (*)
15	Piston Guide	See Table 19	1 (*)
16	O-Ring	See Table 19	1 (*)
17	Metallic Ring	OR-00088	1
18	Metallic Ring	OR-00082	1
19	Metallic Ring	OR-00023	1
20	Lower Ball	TN-00013	1
21	Upper Ball	TN-00012	1
22	Plug	RA-00211	1
23	Exit Elbow	RA-00145	1
24	Washer	TN-00028	4
25	Allen Screw	TN-00062	4
26	Seeger Ring	See Table 18	1
27	Pin	See Table 18	1
28	Grease Fiting	TN-00073	1

N.B.: The parts marked with (*), are included in the repair seal kit of “R” pump (see Table 20).

The parts marked with (#), are not supplied separately.



Table 18. "R" Proportioning Pump Assembly, Parts List

Pump	Item 1	Item 2 (2.1 + 2.2)	Item 2.1	Item 2.2
1.20 (#)	NPU-06001-012	PU-01006-012	PU-01007-012	PU-01008-012
0.80	NPU-06001-008	PU-01006-008	PU-01007-008	PU-01008-008

Pump	Item 5	Item 8	Item 26	Item 27
1.20 (#)	PU-01010-012	PU-06006-012G	TN-00070	TN-00086
0.80	PU-01010-008	PU-06006-008G	TN-00067	TN-00085

Table 19. Seals Monobloc "R" Pump

Ítem	1.20 (#)	0.80
9	PU-06008-012	PU-06008-008
13	PU-01016-012A	PU-01016-008A
14	PU-01017-012G	PU-01017-008G
15	PU-01014-012A	PU-01014-008A
16	OR-00009	OR-00009

Table 20. Repair Seal Kit "R" Pump

Pump	Item
1.20 (#)	KT-00158
0.80	KT-00160

N.B :

(#) The standard proportioning pump size is #1.20. Different sizes are available under order. For delivery time, please consult with marketing department.

The Repair seal kit include the parts indicated (*) in the Table 17.



“A” STANDARD PRIMARY HEATER

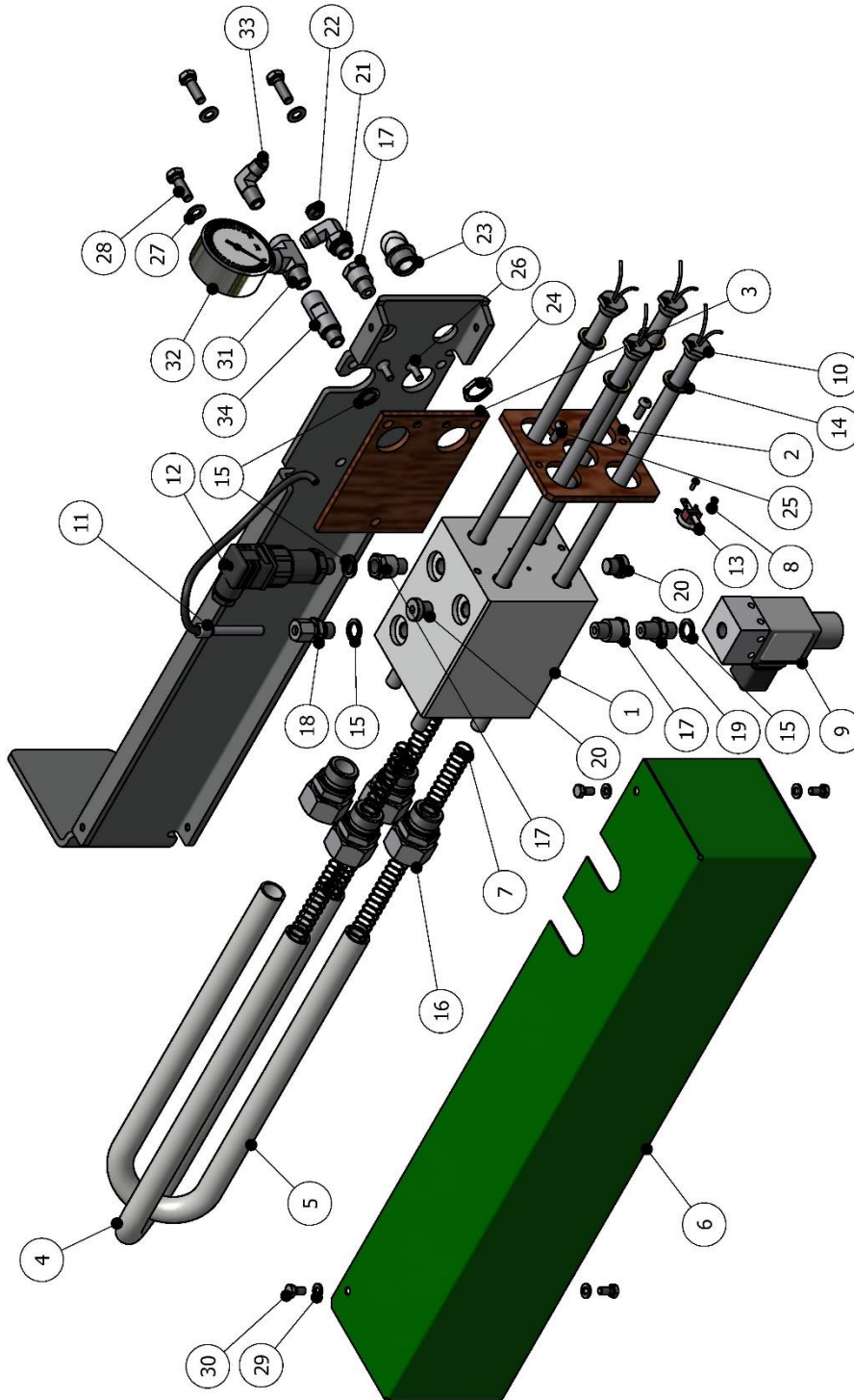

Figure 10. “A” Standard Primary Heater, Exploded View

**Table 21. "A" Standard Primary Heater, Parts List**

Item	Description	Part Number	Qty.
1	Heater Block	NCL-03001-02A	1
2	Front Insulate Plate	NCL-03001-03A	1
3	Side Insulate Plate	NCL-03001-04	1
4	Long Pipe	NCL-03001-05	1
5	Short Pipe	NCL-03001-06	1
6	Heater Cover	NCL-03001-07	1
7	Spring	SP-00030	3
8	Screw	TN-00128	2
9	Pressure Switch	HI-00021	1
10	Heat Resistance	See Table 22	4
11	Thermocouple	EL-00156-01	1
12	Transducer	HI-00033	1
13	Thermal Limit Switch	EL-00006	1
14	Metal O-Ring	OR-00018	4
15	Metal O-Ring	OR-00054	4
16	Male Connector	RA-00468	4
17	Extension Nipple	RA-00077	3
18	Male Connector for Thermocouple	RA-00231	1
19	Union	RA-00138	1
20	Plug	RA-00013	2
21	Elbow 90°	RA-00050	1
22	Grommet	EL-00095-00	1
23	Plastic Elbow	EL-00087-01	1
24	Nut	EL-00090-01	1
25	"ULS" Screw	TN-00424	2
26	Screw	TN-00322	2
27	Washer	TN-00119	3
28	Hex. Cap Screw	TN-00146	3



Item	Description	Part Number	Qty.
29	Washer	TN-00024	4
30	Hex. Cap Screw	TN-00438	4
31	"T" Adapter	RA-00018	1
32	Pressure Gauge	See Table 22	1
33	Elbow 90°	RA-00254	1
34	Extension Nipple	RA-00100	1

Table 22. "A" Heat Resistance & Press. Gauge Reference List

Item	Description	Part Number	Qty.
10	Heat Resistance 400v 1500w	EL-00179	4
	Heat Resistance 400v 1250w	EL-00197	4
	Heat Resistance 230v 1500w	EL-00035	4
32	Pressure Gauge for 200 bar	NHI-00019	1
	Pressure Gauge for 300 bar	NHI-00035	1



“R” STANDARD PRIMARY HEATER

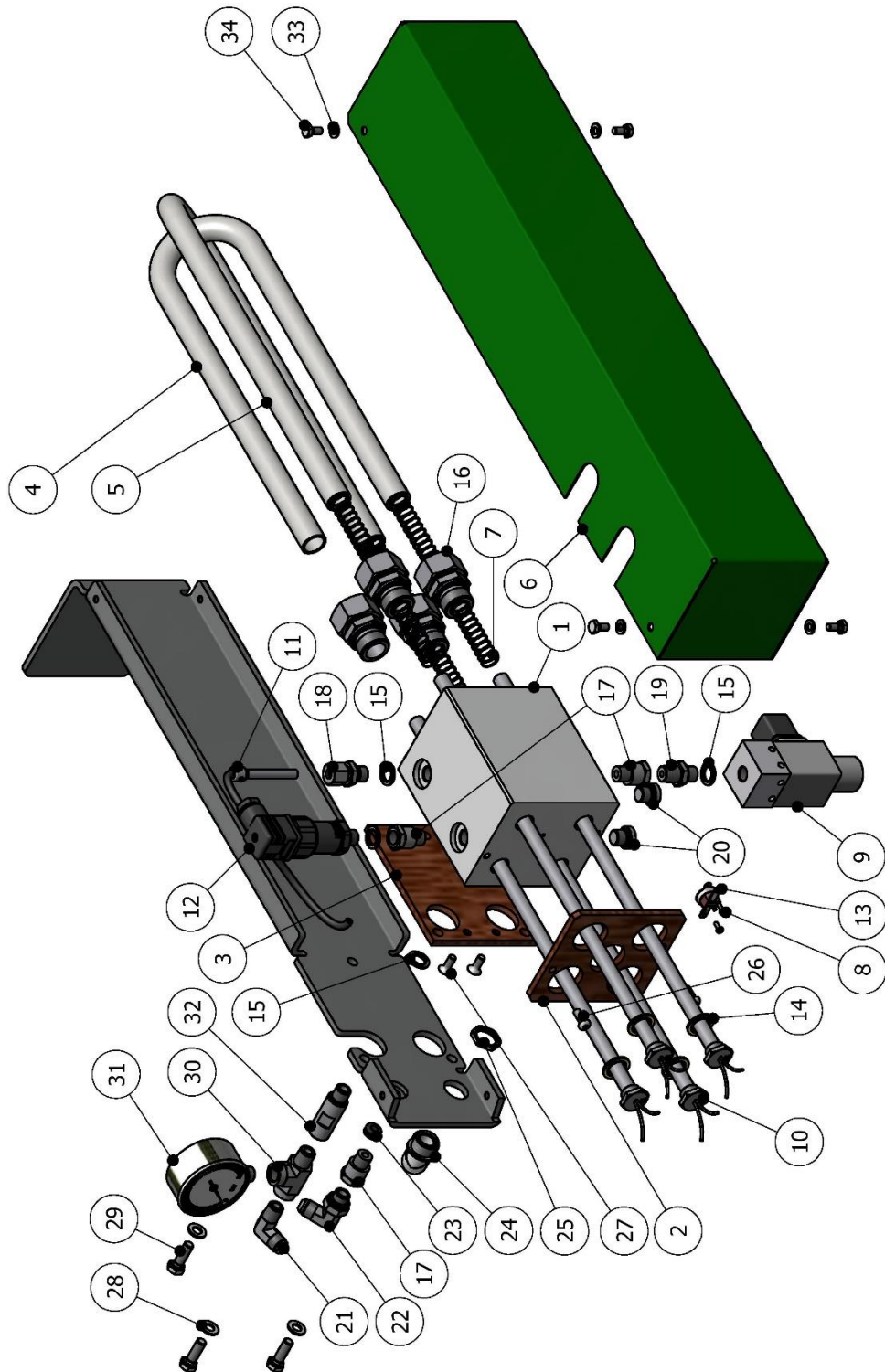

Figure 11. “R” Standard Primary Heater, Exploded View



Table 23. “R” Standard Primary Heater, Parts List

Item	Description	Part Number	Qty.
1	Heater Block	NCL-03001-02A	1
2	Front Insulate Plate	NCL-03001-03A	1
3	Side Insulate Plate	NCL-03001-04	1
4	Short Pipe	NCL-03001-06	1
5	Long Pipe	NCL-03001-05	1
6	Heater Cover	NCL-03002-07	1
7	Spring	SP-00030	3
8	Screw	TN-00128	2
9	Pressure Switch	HI-00021	1
10	Heat Resistance	See Table 24	4
11	Thermocouple	EL-00156-01	1
12	Transducer	HI-00033	1
13	Thermal Limit Switch	EL-00006	1
14	Metal O-Ring	OR-00018	4
15	Metal O-Ring	OR-00054	4
16	Male Connector	RA-00468	4
17	Extension Nipple	RA-00077	3
18	Male Connector for Thermocouple	RA-00231	1
19	Union	RA-00138	1
20	Plug	RA-00013	2
21	Elbow 90°	RA-00044	1
22	Elbow 90°	RA-00050	1
23	Grommet	EL-00095-00	1
24	Plastic Elbow	EL-00087-01	1
25	Nut	EL-00090-01	1
26	“ULS” Screw	TN-00424	2
27	Screw	TN-00322	2
28	Washer	TN-00119	3
29	Hex. Cap Screw	TN-00146	3



Item	Description	Part Number	Qty.
30	"T" Adapter	RA-00018	1
31	Pressure Gauge	See Table 24	1
32	Extension Nipple	RA-00100	1
33	Washer	TN-00024	4
34	Hex. Cap Screw	TN-00438	4

Table 24. "R" Heat Resistance & Press. Gauge Reference List

Item	Description	Part Number	Qty.
10	Heat Resistance 400v 1500w	EL-00179	4
	Heat Resistance 400v 1250w	EL-00197	4
	Heat Resistance 230v 1500w	EL-00035	4
31	Pressure Gauge for 200 bar	NHI-00019	1
	Pressure Gauge for 300 bar	NHI-00035	1



RECIRCULATION KIT P#: KT-00038

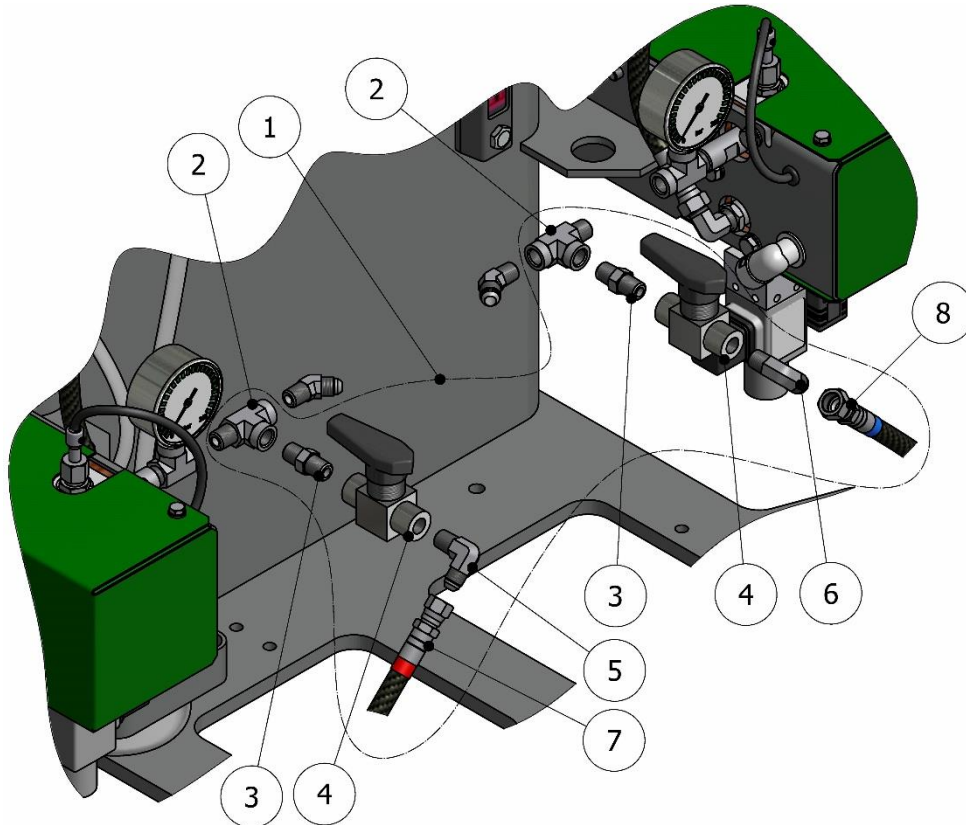

Figure 12. Recirculation Kit P#: KT-00038, Exploded View

Table 25. Standard Recirculation Kit, Parts List

Item	Description	Part Number	Qty.
1	Recirculation Kit	KT-00038	1
2	"T" Union	RA-00018	2
3	Male Union	RA-00188	2
4	Ball Valve	RA-00189	2
5	Elbow 90° ISO Side	RA-00254	1
6	Elbow 90° POL Side	RA-00044	1
7	A-Hose	MA-00050-01	1
8	R-Hose	MA-00050-00	1



RECIRCULATION KIT P#: KT-00038-01

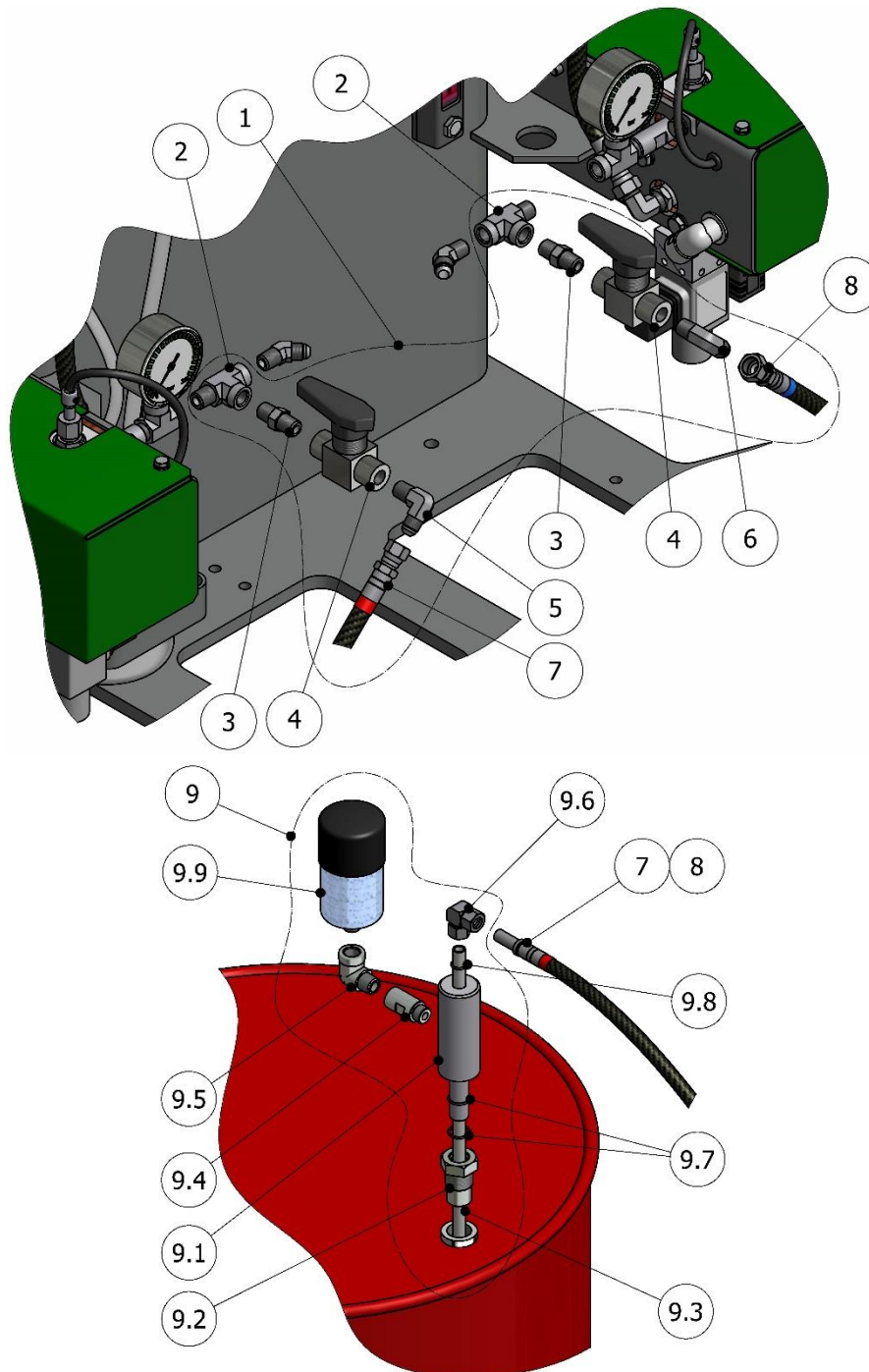

Figure 13. Recirculation Kit P#: KT-00038-01, Exploded View



Table 26. Recirculation Kit #KT-00038-01, Parts List

Item	Description	Part Number	Qty.
1	Recirculation Kit	KT-00038-01	1
2	"T" Union	RA-00018	2
3	Male Union	RA-00188	2
4	Ball Valve	RA-00189	2
5	Elbow 90° ISO Side	RA-00254	1
6	Elbow 90° POL Side	RA-00044	1
7	A-Hose	MA-00050-01	1
8	R-Hose	MA-00050-00	1
9	Assy. Connection to Tank with Filter	MQ-05009-00	2
9.1	Body Connection	MQ-05010	1 (*)
9.2	Connection Tank	MQ-05009	1 (*)
9.3	Pipe	HI-00075	1 (*)
9.4	Extension	RA-00256	1 (*)
9.5	Elbow	RA-00257	1 (*)
9.6	Elbow for Pipe	RA-00200	1 (*)
9.7	O-Ring	OR-00055	2(*)
9.8	O-Ring	OR-00011	1 (*)
9.9	Dehumidifier Filter	NE-00045	1 (*)

N.B.:

(*) Unitary Quantities included in 1 set of item.9



RECIRCULATION KIT P#: KT-00038-03

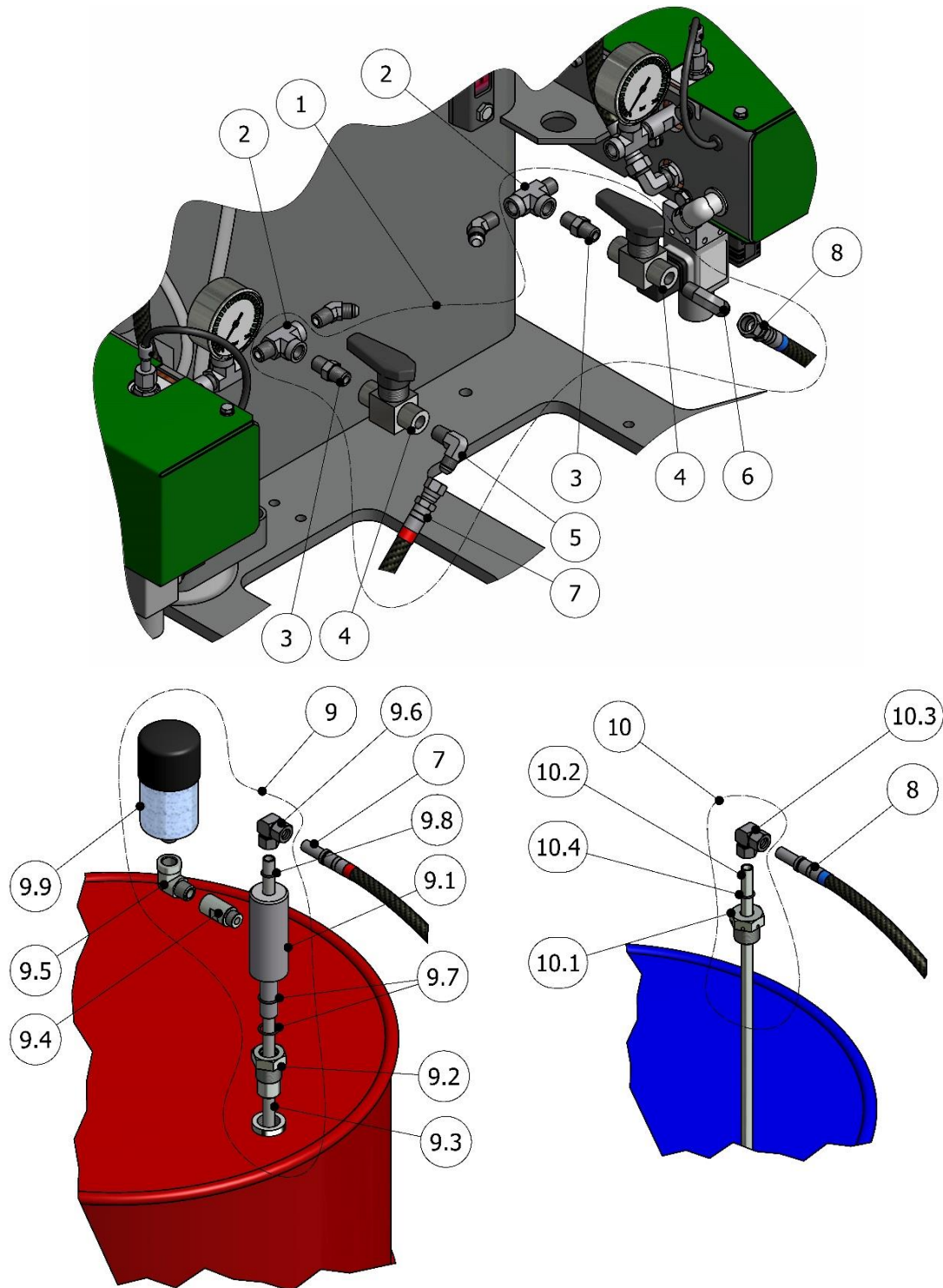

Figure 14. Recirculation Kit P#: KT-00038-03, Exploded View



Table 27. Recirculation Kit #KT-00038-03, Parts List

Item	Description	Part Number	Qty.
1	Recirculation Kit	KT-00038-03	1
2	"T" Union	RA-00018	2
3	Male Union	RA-00188	2
4	Ball Valve	RA-00189	2
5	Elbow 90° ISO Side	RA-00254	1
6	Elbow 90° POL Side	RA-00044	1
7	A-Hose	MA-00050-01	1
8	R-Hose	MA-00050-00	1
9	Assy. Connection to Tank with Filter	MQ-05009-00	1
9.1	Body Connection	MQ-05010	1
9.2	Connection Tank	MQ-05009	1
9.3	Pipe	HI-00075	1
9.4	Extension	RA-00256	1
9.5	Elbow	RA-00257	1
9.6	Elbow for Pipe	RA-00200	1
9.7	O-Ring	OR-00055	2
9.8	O-Ring	OR-00011	1
9.9	Dehumidifier Filter	NE-00045	1
10	Assy. Connection to Tank w/o Filter	MQ-05010-00	1
10.1	Connection Tank	MQ-05009-A	1
10.2	Pipe	HI-00075	1
10.3	Elbow for Pipe	RA-00200	1
10.4	O-ring	OR-00011	1



ELECTRICAL SCHEMATIC DIAGRAM 3PE~400V 50/60Hz

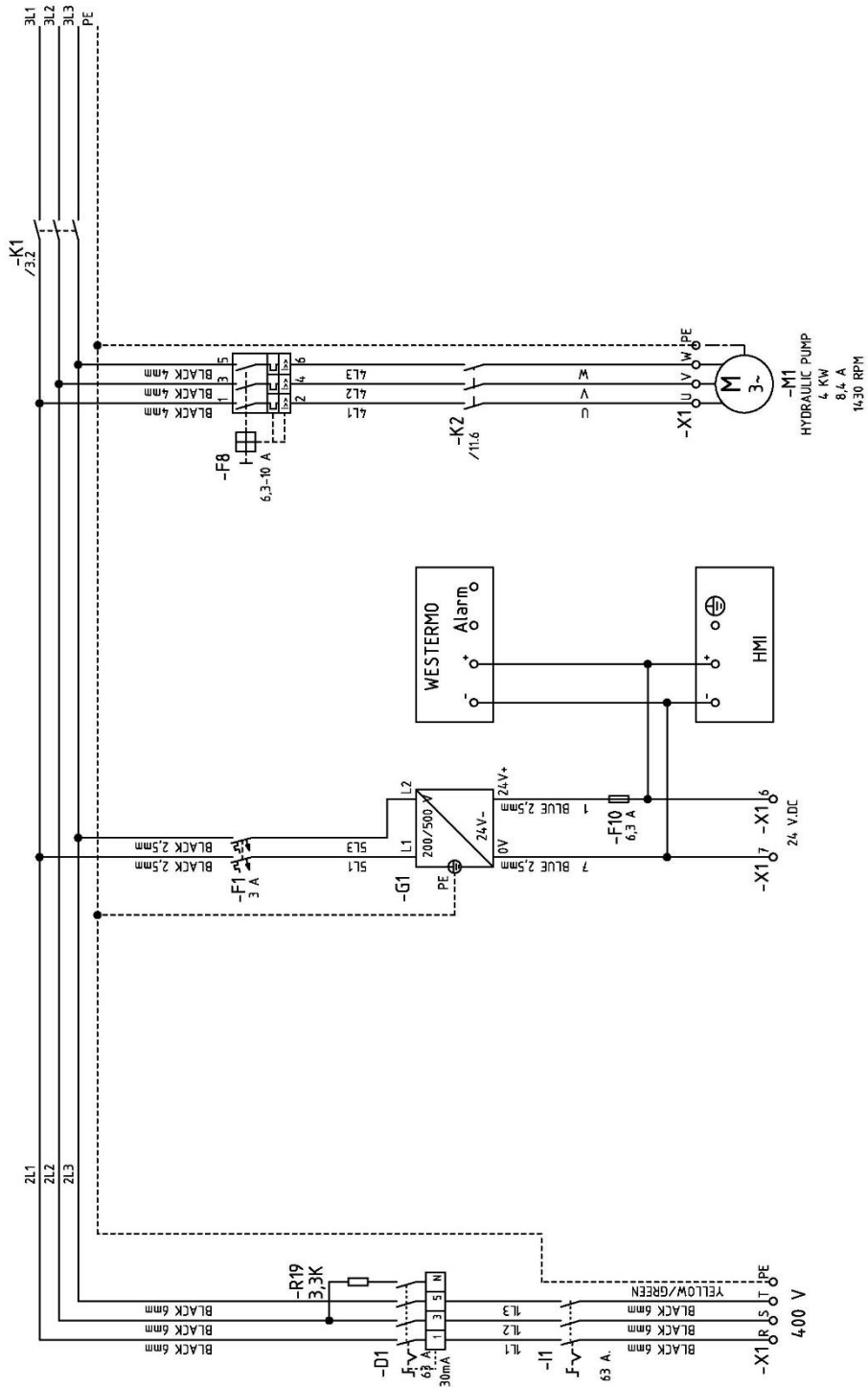

Figure 15. Elec. Schem. 3PE~400V 50/60Hz Standard Vers. (Sheet 1/12)

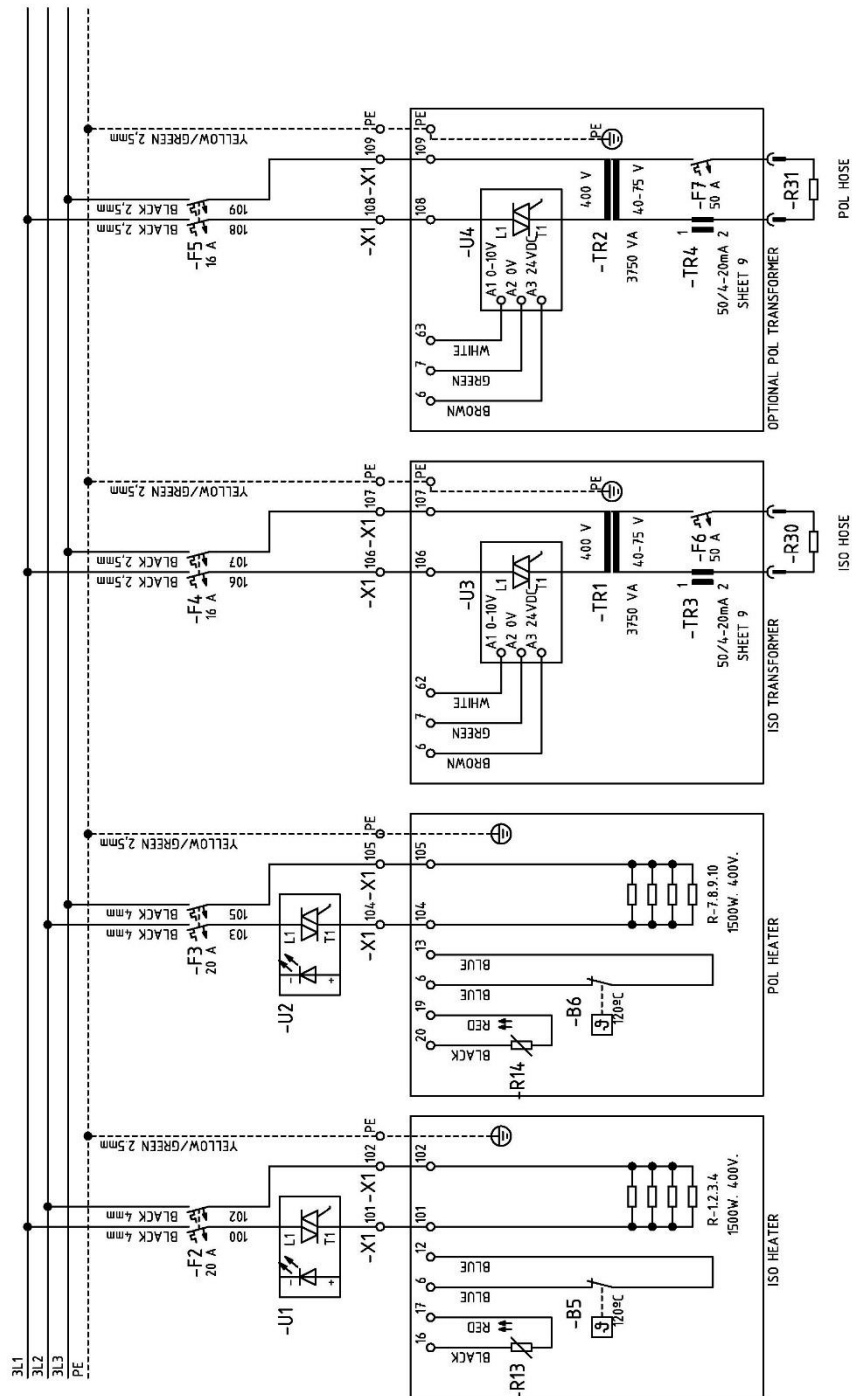

Figure 16. Elec. Schem. 3PE~400V 50/60Hz Standard Vers. (Sheet 2/12)

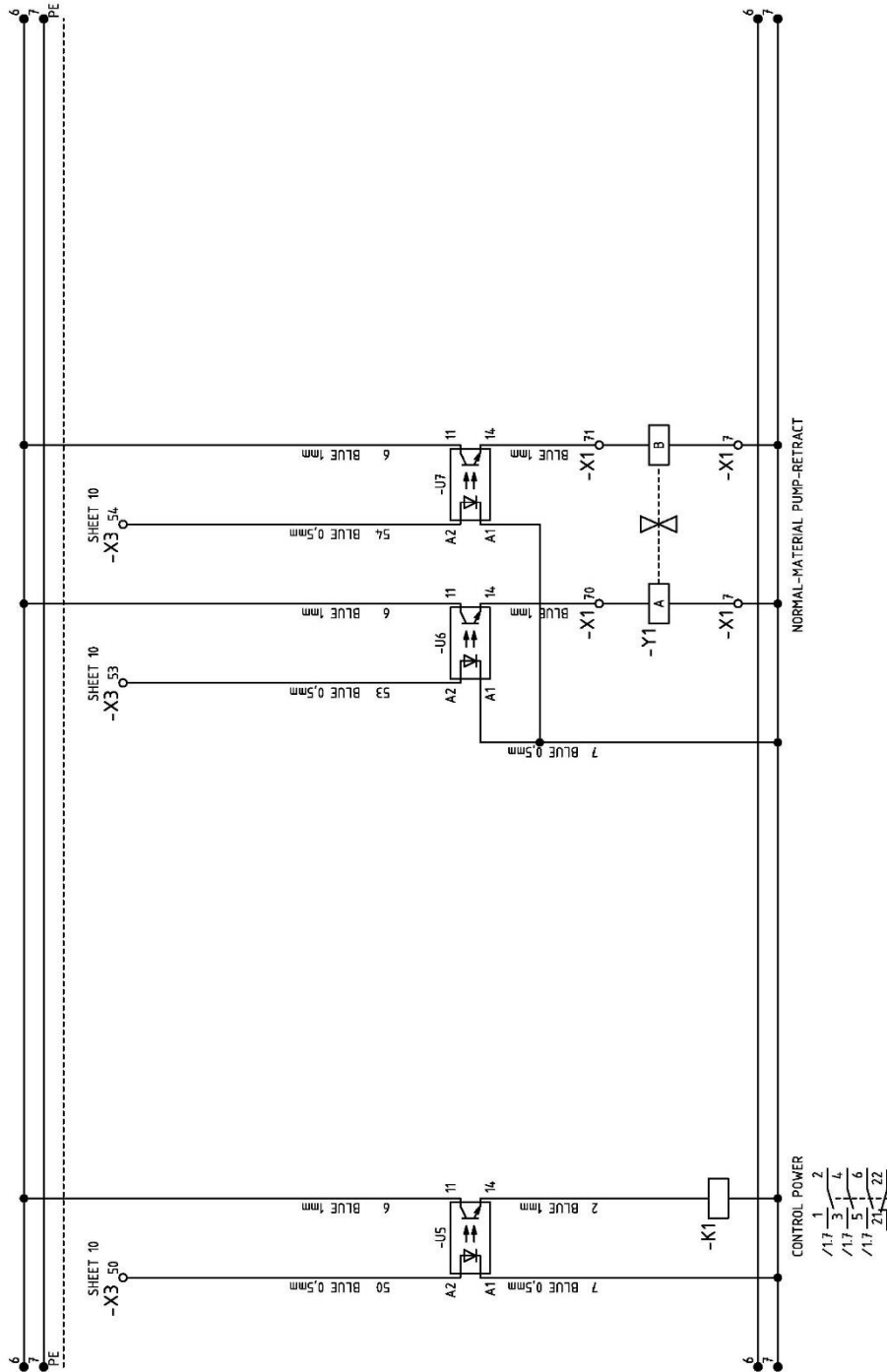

Figure 17. Elec. Schem. 3PE~400V 50/60Hz Standard Vers. (Sheet 3/12)

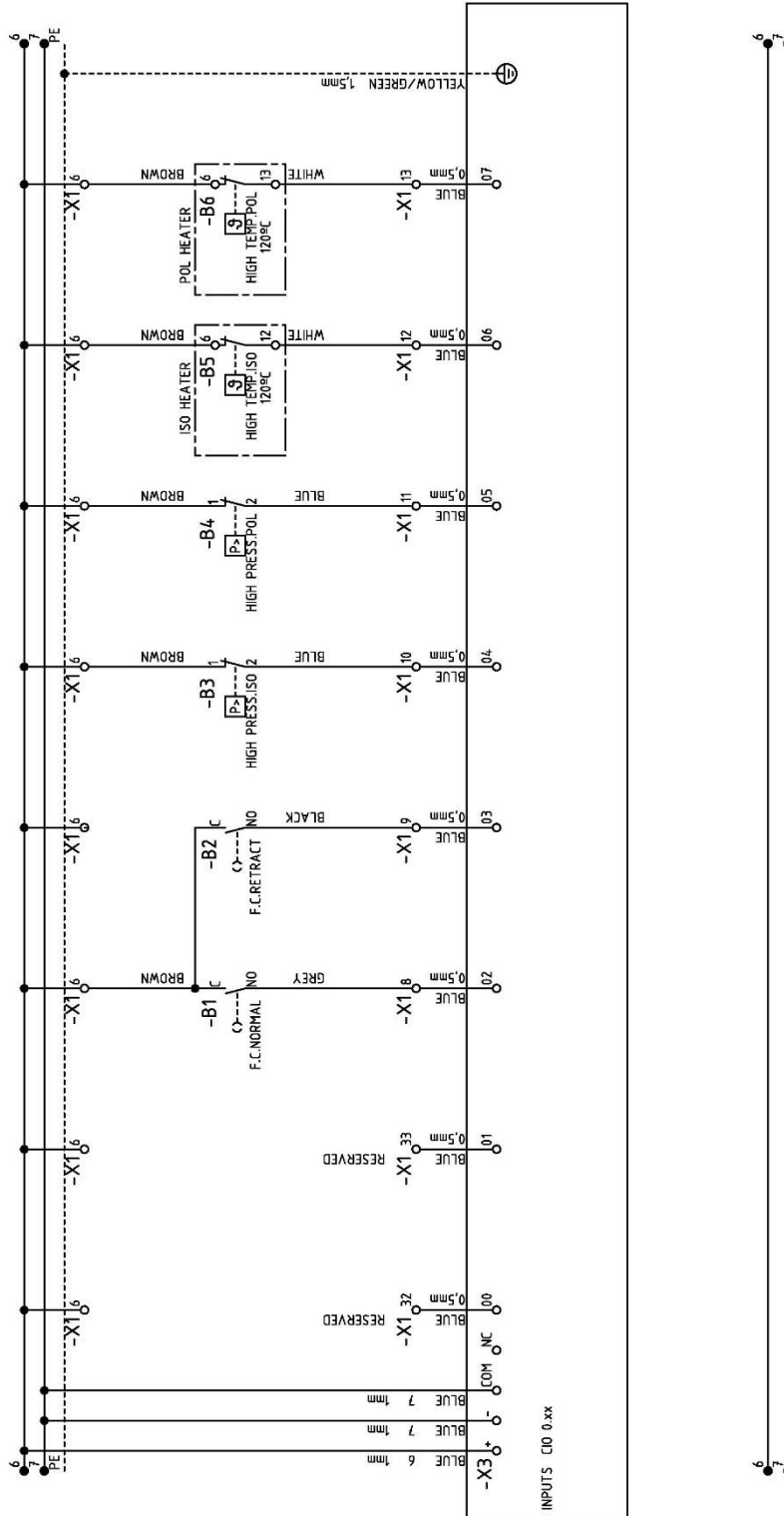

Figure 18. Elec. Schem. 3PE~400V 50/60Hz Standard Vers. (Sheet 4/12)

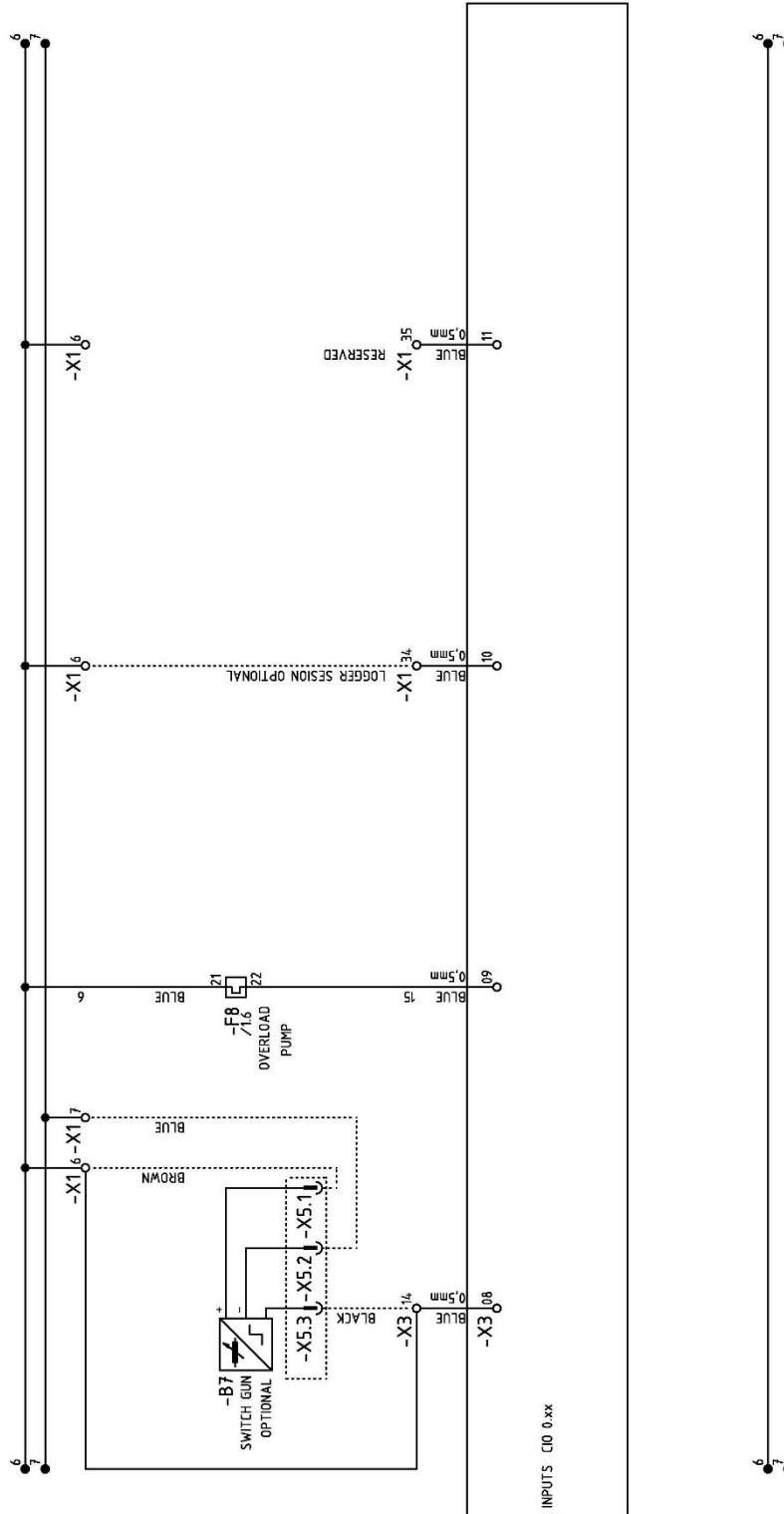

Figure 19. Elec. Schem. 3PE~400V 50/60Hz Standard Vers. (Sheet 5/12)

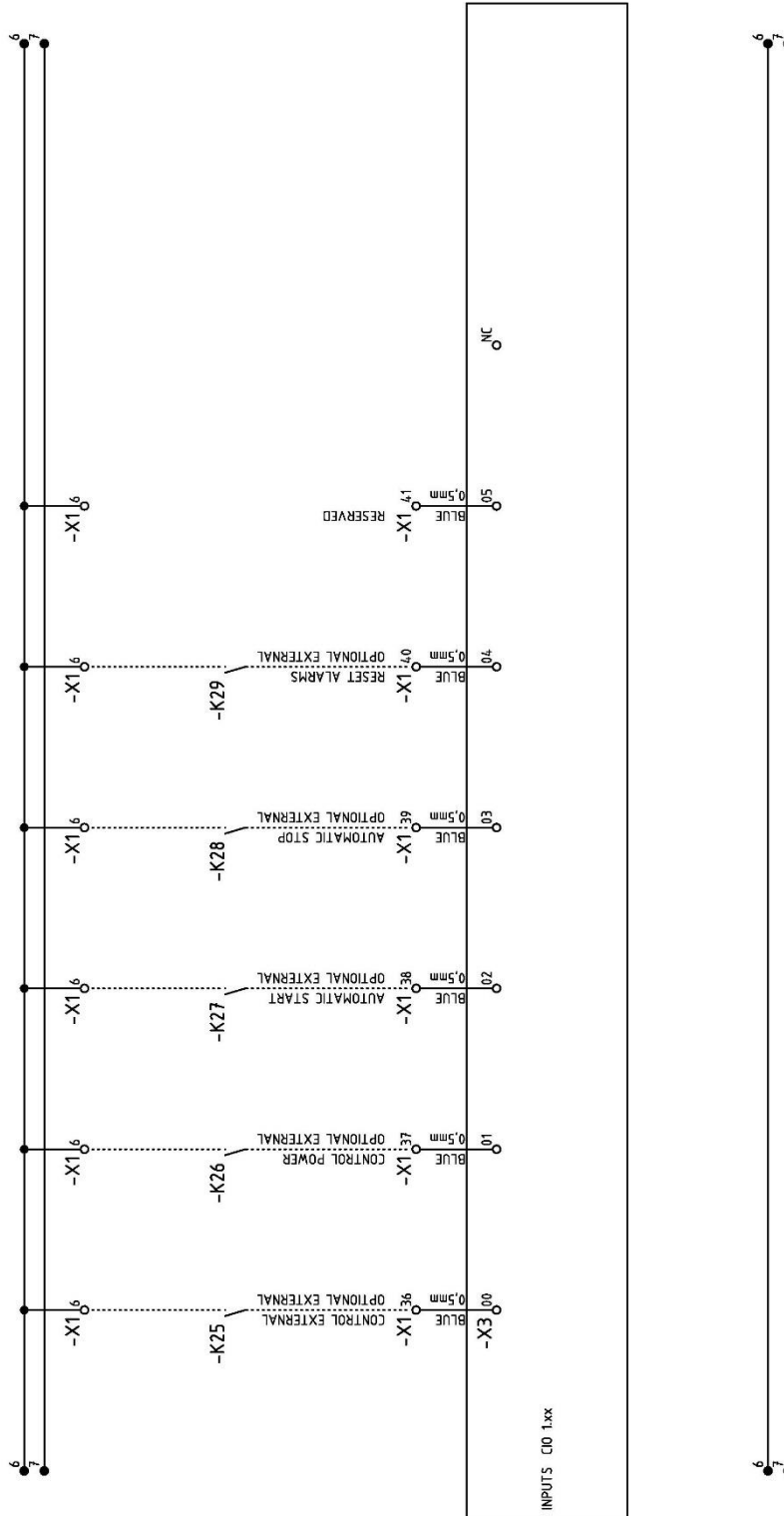

Figure 20. Elec. Schem. 3PE~400V 50/60Hz Standard Vers. (Sheet 6/12)

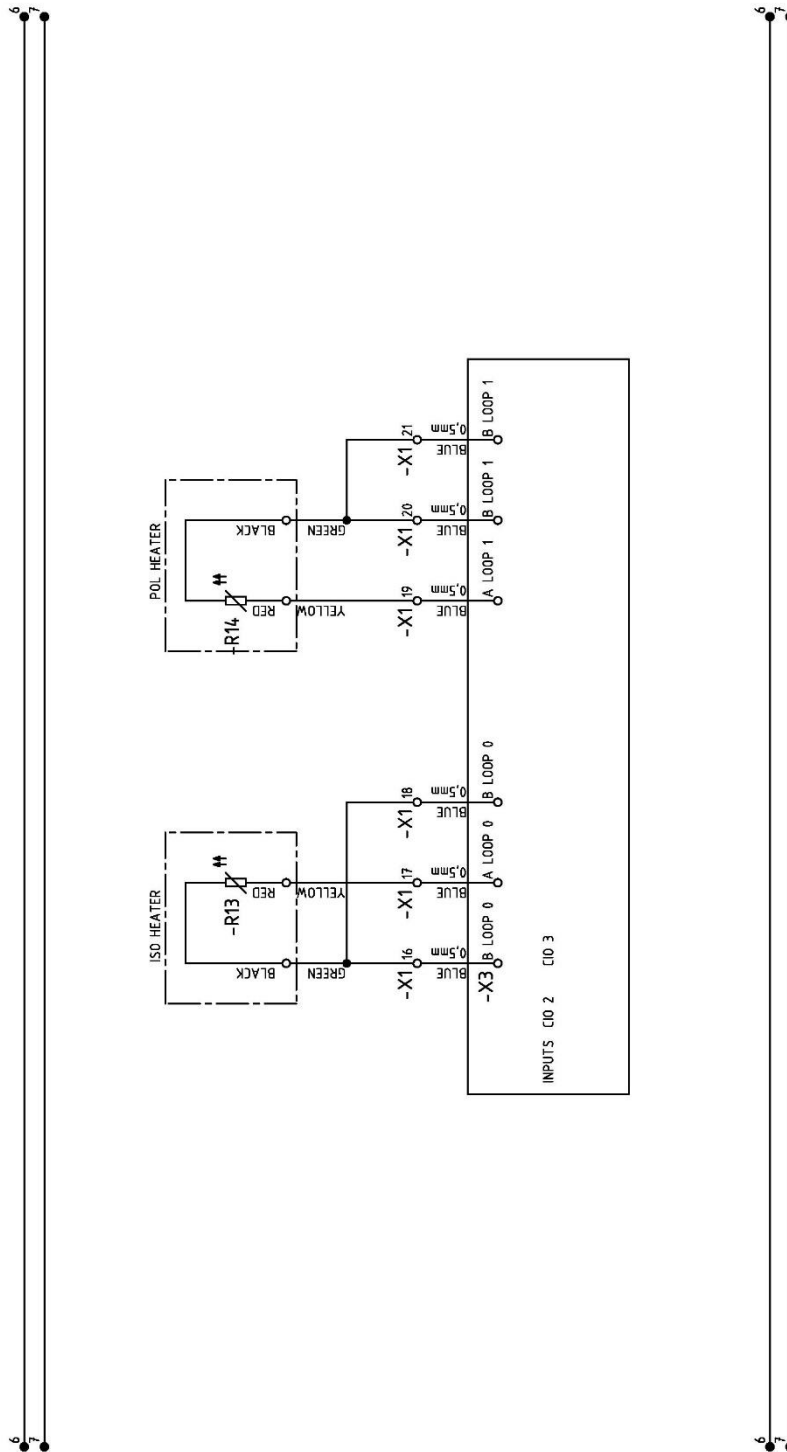

Figure 21. Elec. Schem. 3PE~400V 50/60Hz Standard Vers. (Sheet 7/12)

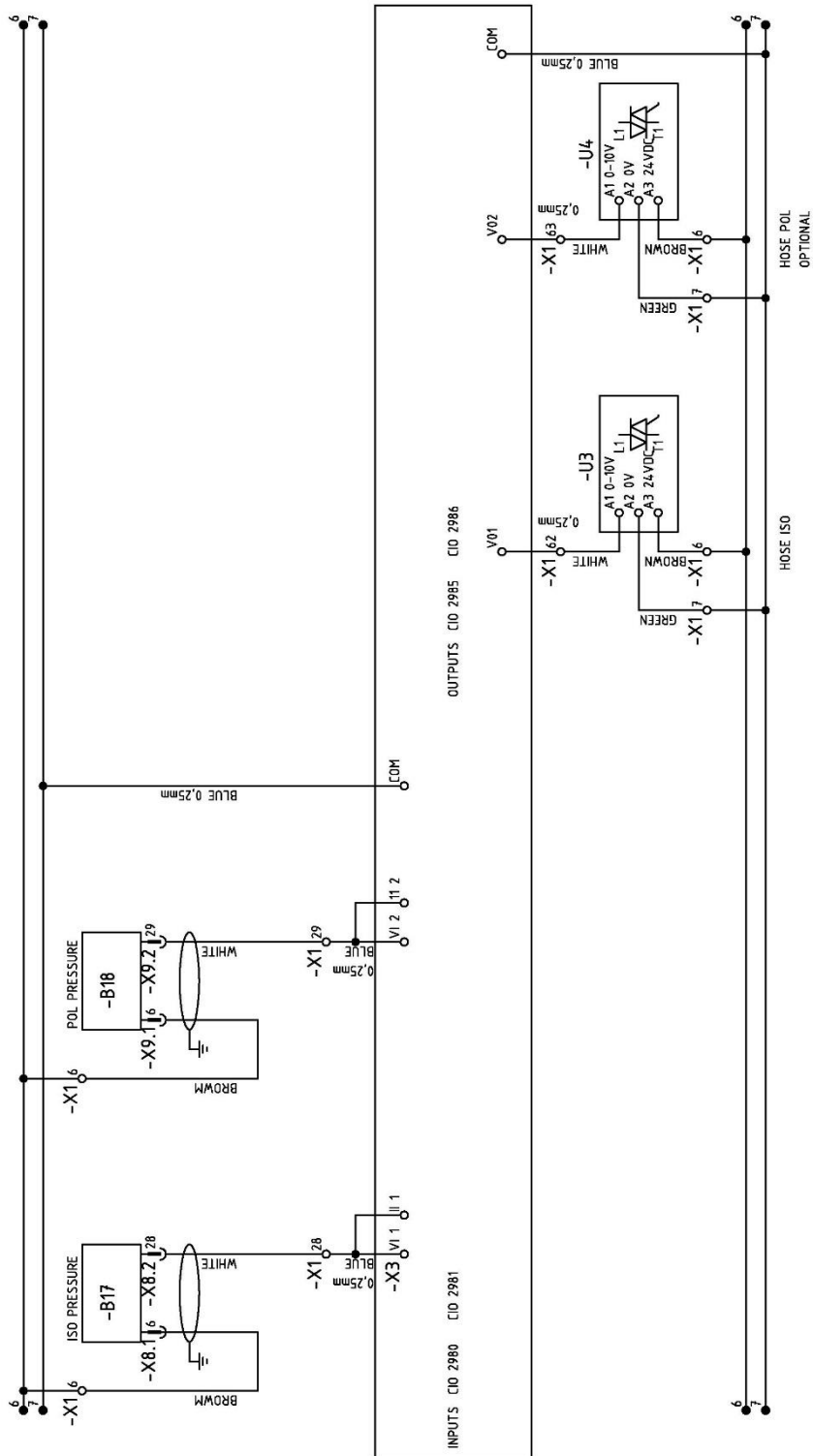

Figure 22. Elec. Schem. 3PE~400V 50/60Hz Standard Vers. (Sheet 8/12)

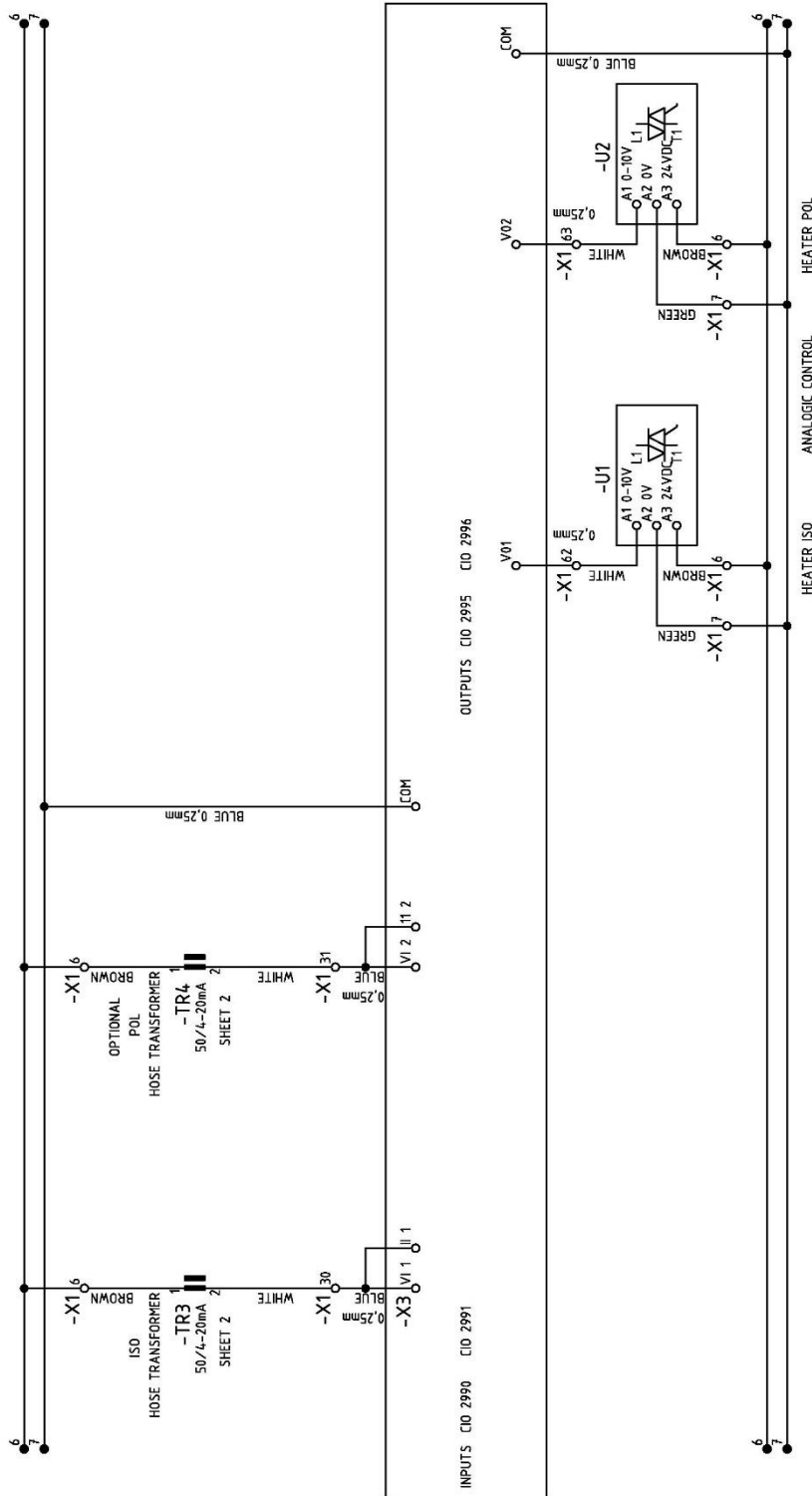

Figure 23. Elec. Schem. 3PE~400V 50/60Hz Standard Vers. (Sheet 9/12)

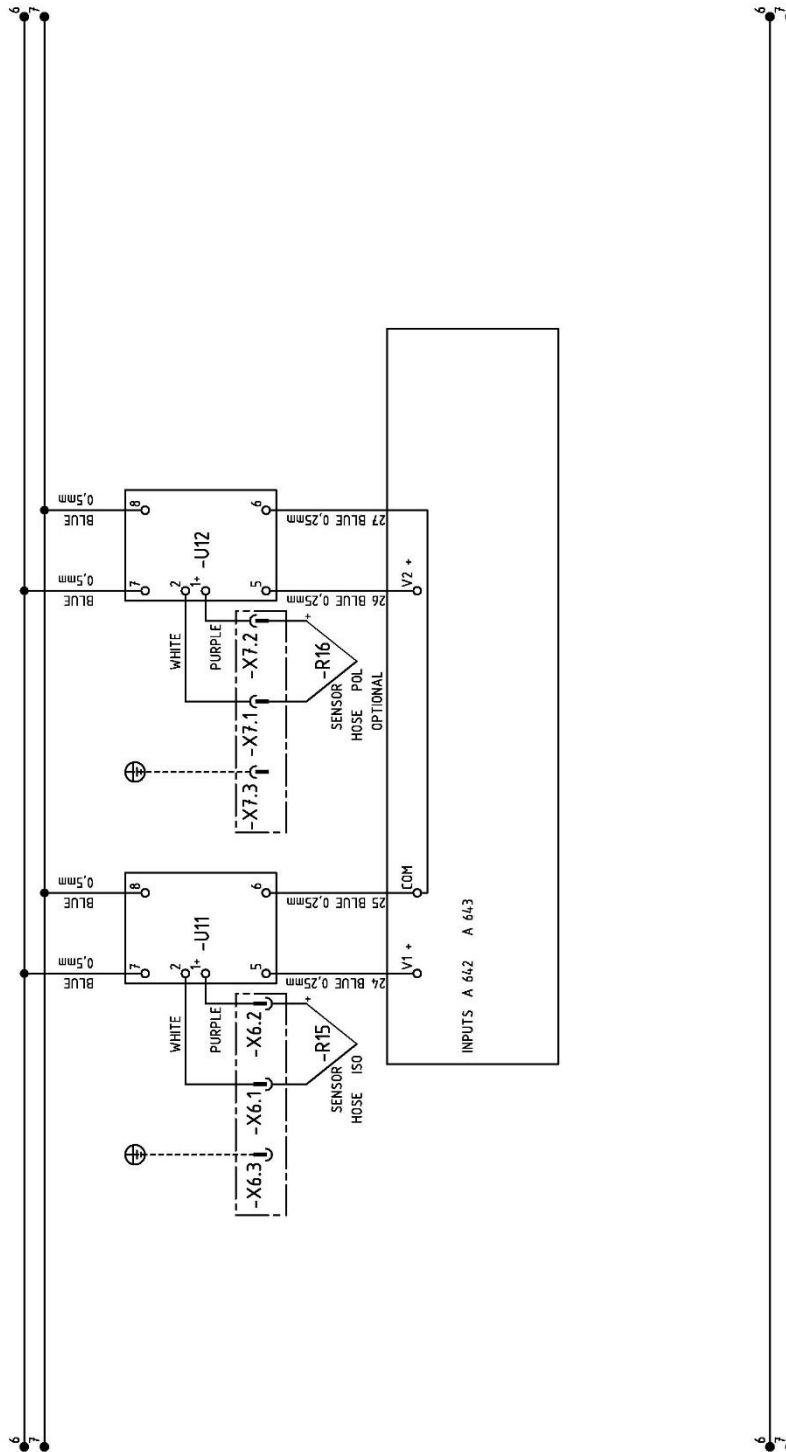

Figure 24. Elec. Schem. 3PE~400V 50/60Hz Standard Vers. (Sheet 10/12)

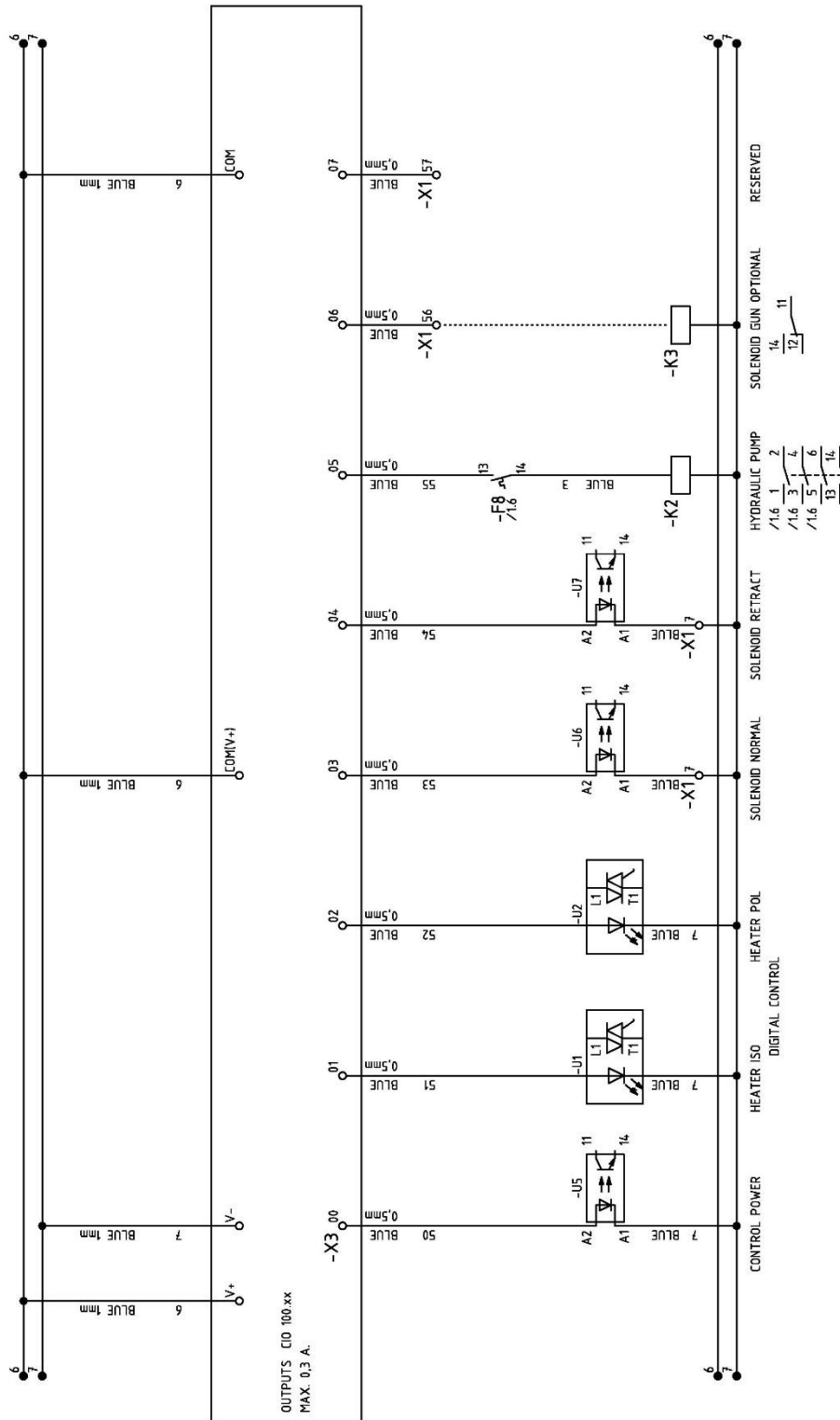

Figure 25. Elec. Schem. 3PE~400V 50/60Hz Standard Vers. (Sheet 11/12)

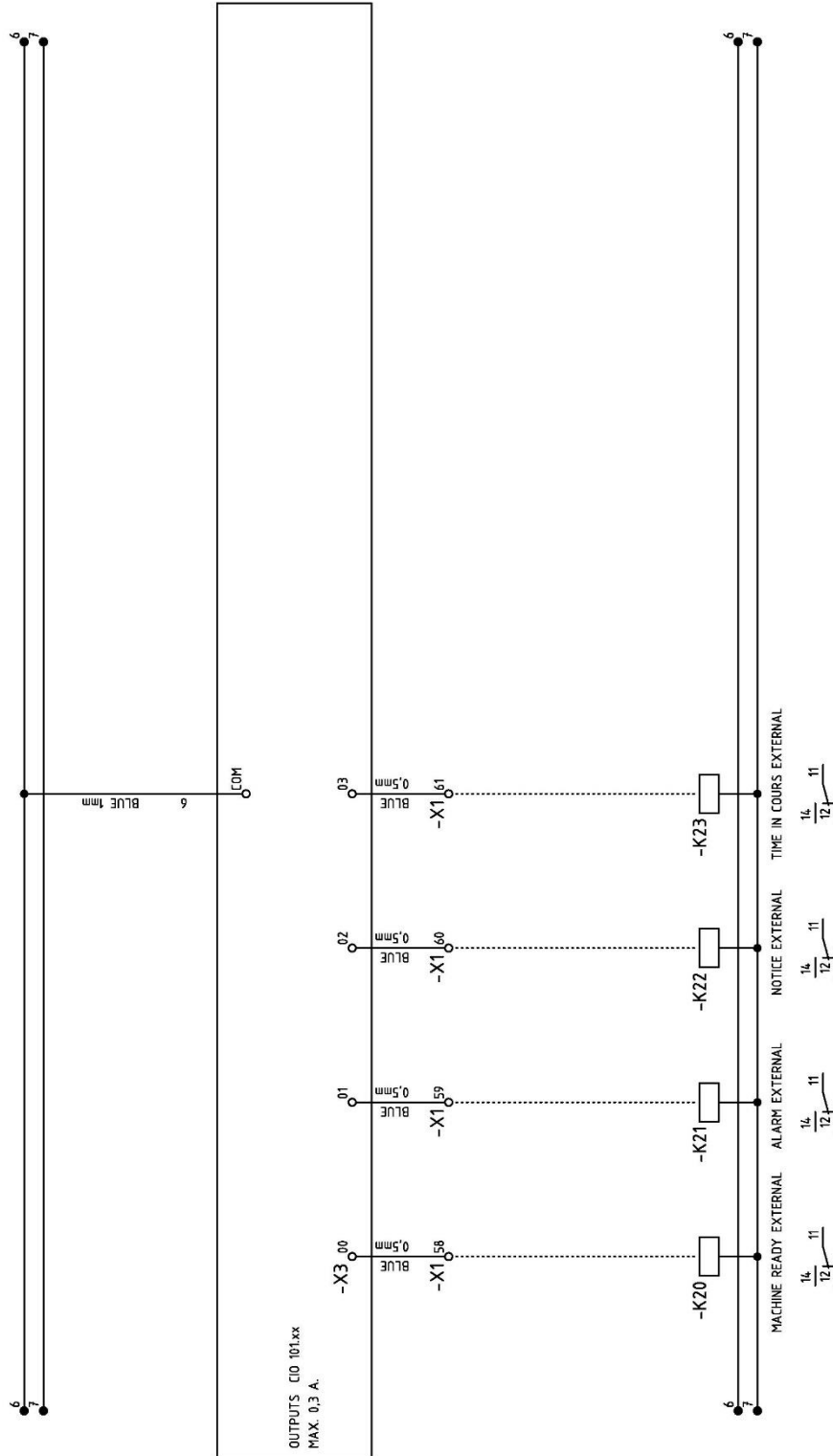

Figure 26. Elec. Schem. 3PE~400V 50/60Hz Standard Vers. (Sheet 12/12)

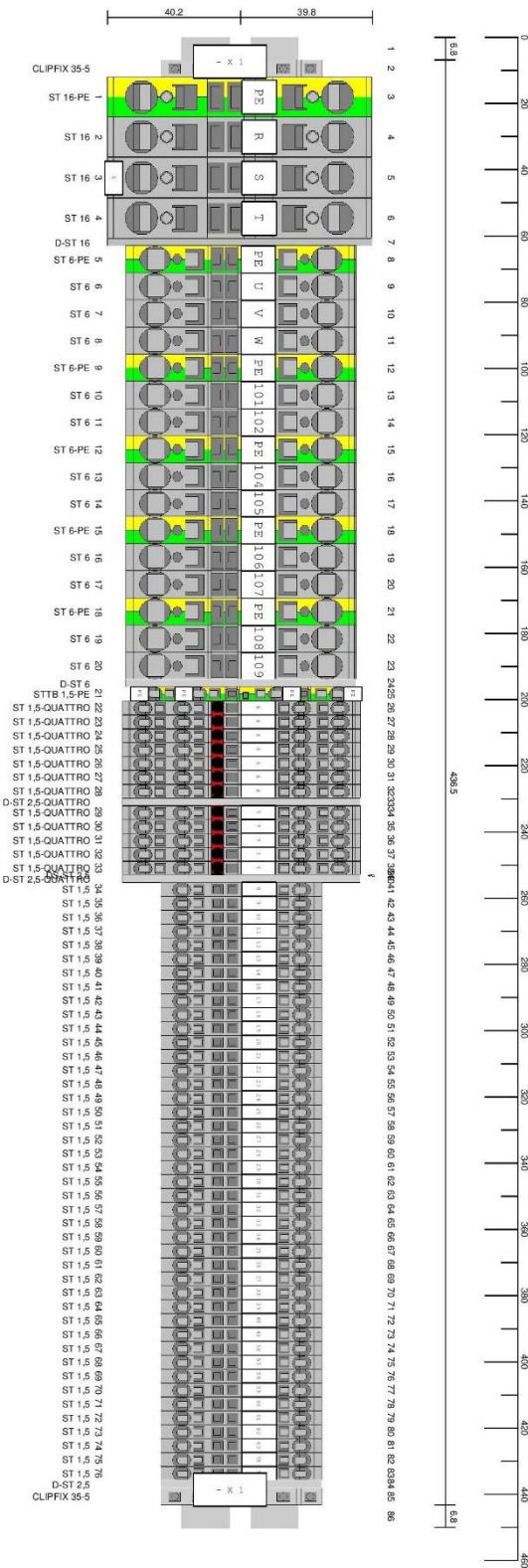
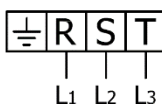

Figure 27. Distribution 3PE~400V 50/60Hz Standard Version



Table 28. Elec. Schem. 3PE~400V 50/60Hz Standard Vers. Parts List

Item	Description	Reference	Qty
F 10	FUSIBLE POINT	EL-00104-13	1
F 10	FUSE	EL-00128-03	2
I 1	SWITCH 63 A	EL-00107-07	1
I 1	CONTROL RED YELLOW	EL-00107-06	1
G1	POWER SUPPLY 400/24 5A	EL-00135-03	1
D1	DIFFERENTIAL SWITCH 0,03 63 A	EL-00108-04	1
F 2,3	CIRCUIT BREAKER	EL-00113-04	2
F 4	CIRCUIT BREAKER	EL-00112-04	1
F 1	CIRCUIT BREAKER	EL-00109-04	1
F 5	CIRCUIT BREAKER 6,3-10 A	EL-00119-04	1
F 5	AUXILIARY CONTACTOR	EL-00119-03	1
T 3	INTENSITY TRANSFORMER 50A 4/20mA	EL-00127-19	1
V 1,2	STATIC RELAY	EL-00126-03	2
V 3	TRIAC	EL-00126-11	1
V 3	CONNECTION TRIAC	EL-00126-12	1
K 1	CONTACTOR 24 VDC	EL-00123-02	1
K 2	CONTACTOR 24 VDC	EL-00121-02	1
	RESISTANCE	EL-00129-01	1
X 1	TERMINAL STRIP	EL-00105-13	1
	BASE STATIC RELAY	EL-00126-07	3
	STATIC RELAY	EL-00126-06	3
	CPU	EL-00171-03	1
	ANALOGIC MODULE 2E 2S	EL-00171-05	1
	ANALOGIC MODULE 2E	EL-00171-04	1
	EXPANSION MODULE 2EPt100	EL-00171-06	1
	SWITCH 5x ETHERNET	EL-00171-07	1
	TOUCH SCREEN 7"	EL-00171-02	1
	WIRE ETHERNET 1.5 MTS	EL-00171-09	1
	WIRE ETHERNET 0.2 MTS	EL-00171-11	1
	MINI MCR-TC-UI-NC	EL-00164-02	1
	USB PORT	EL-00078-06	1
	CONSOLE 500x500	EL-	1
	VENTILATION DEVICE	EL-00158-05	1



3PE~400V 50/60Hz



ELECTRICAL SCHEMATIC DIAGRAM 3PE~230V 60Hz

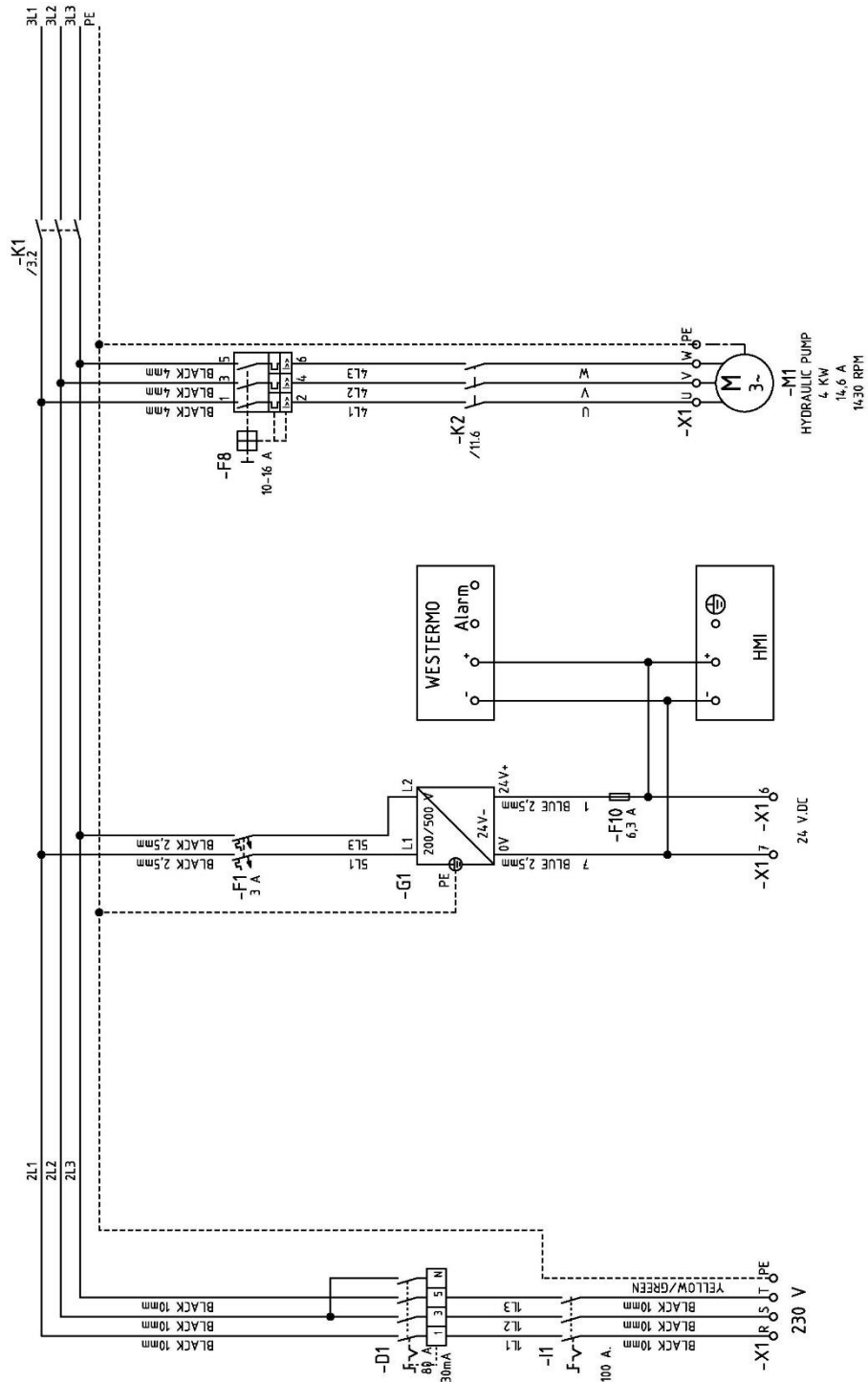

Figure 28. Elec. Schem. 3PE~230V 60Hz Standard Vers. (Sheet 1/12)

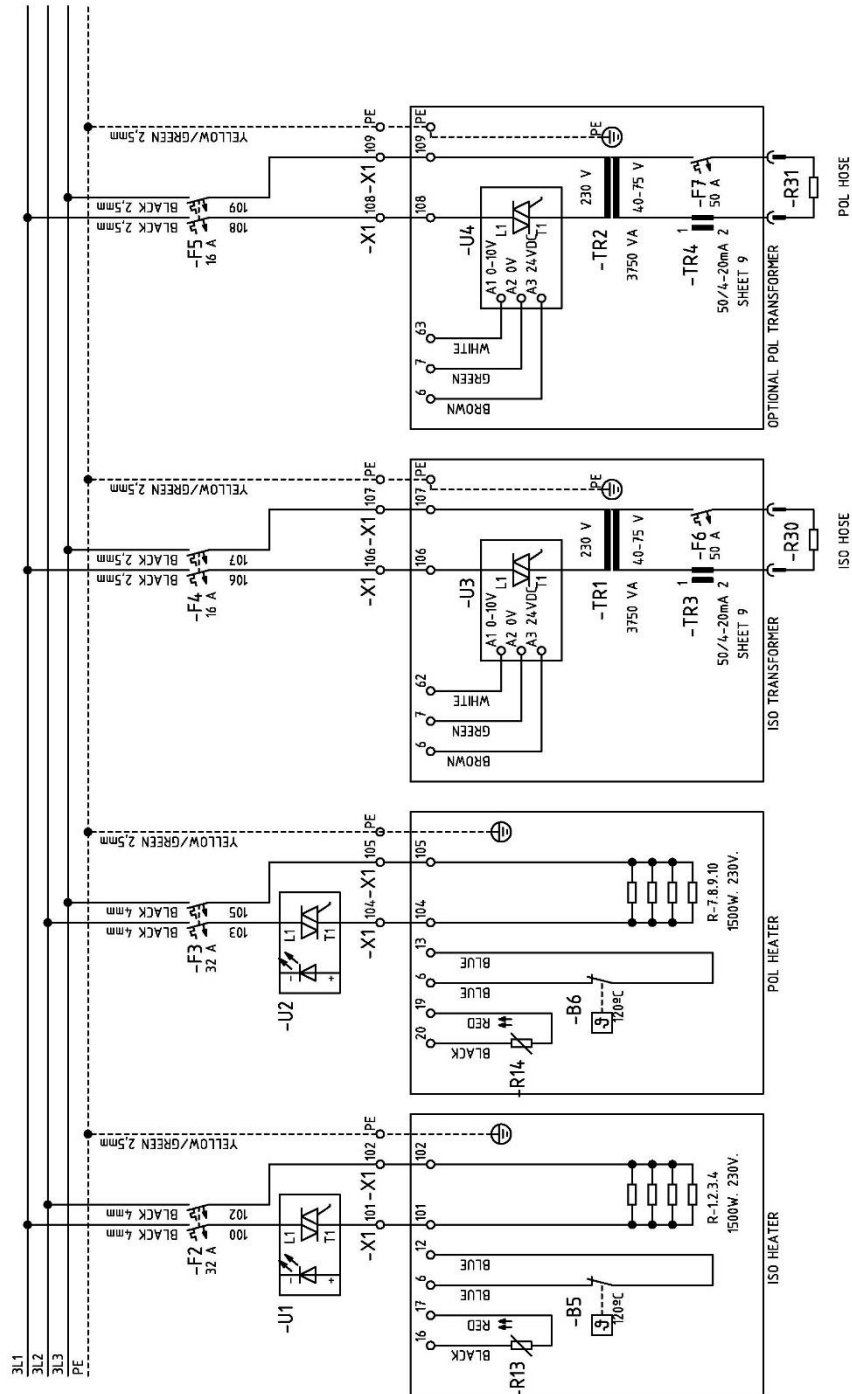

Figure 29. Elec. Schem. 3PE~230V 60Hz Standard Vers. (Sheet 2/12)

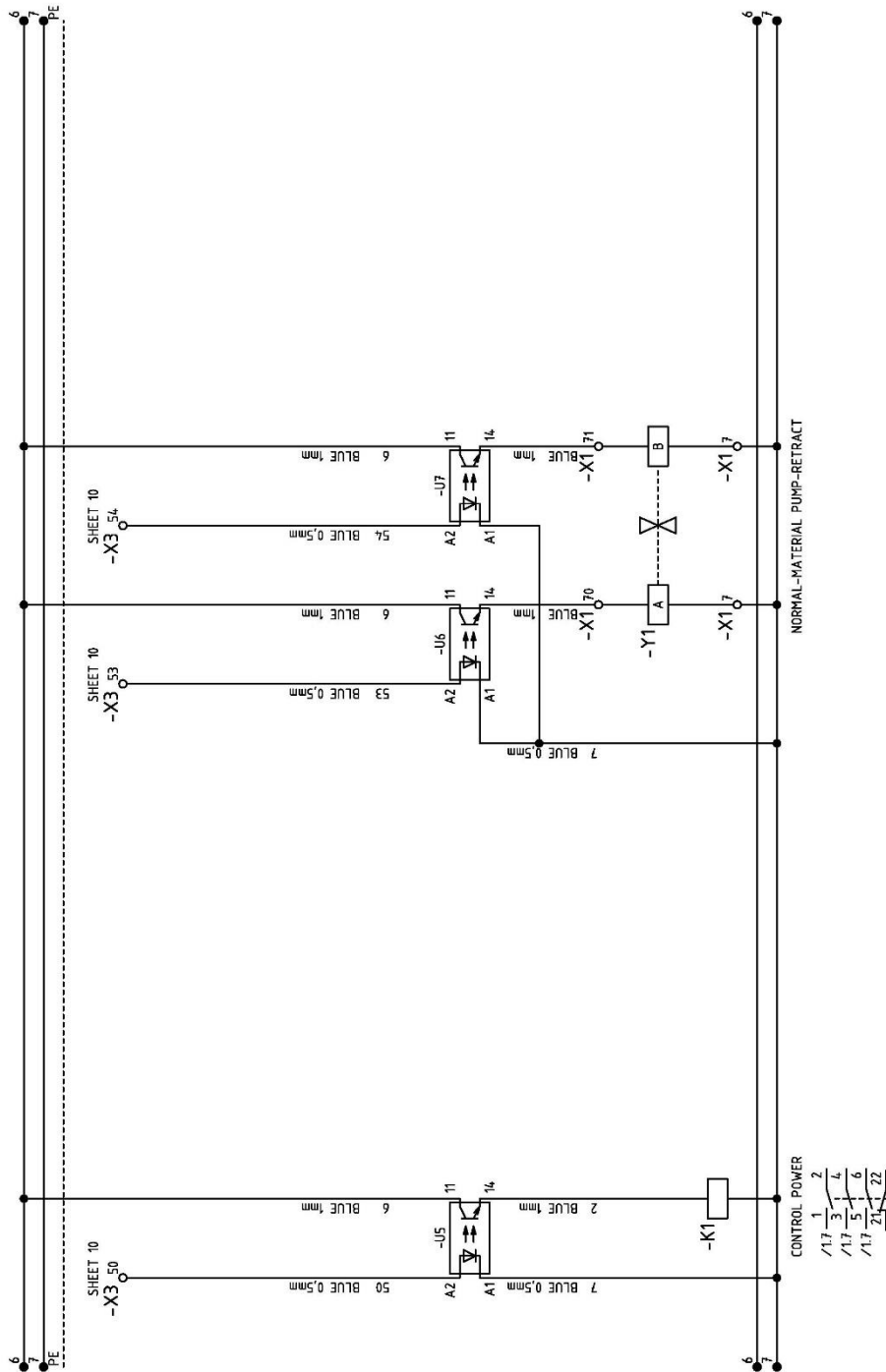

Figure 30. Elec. Schem. 3PE~230V 60Hz Standard Vers. (Sheet 3/12)

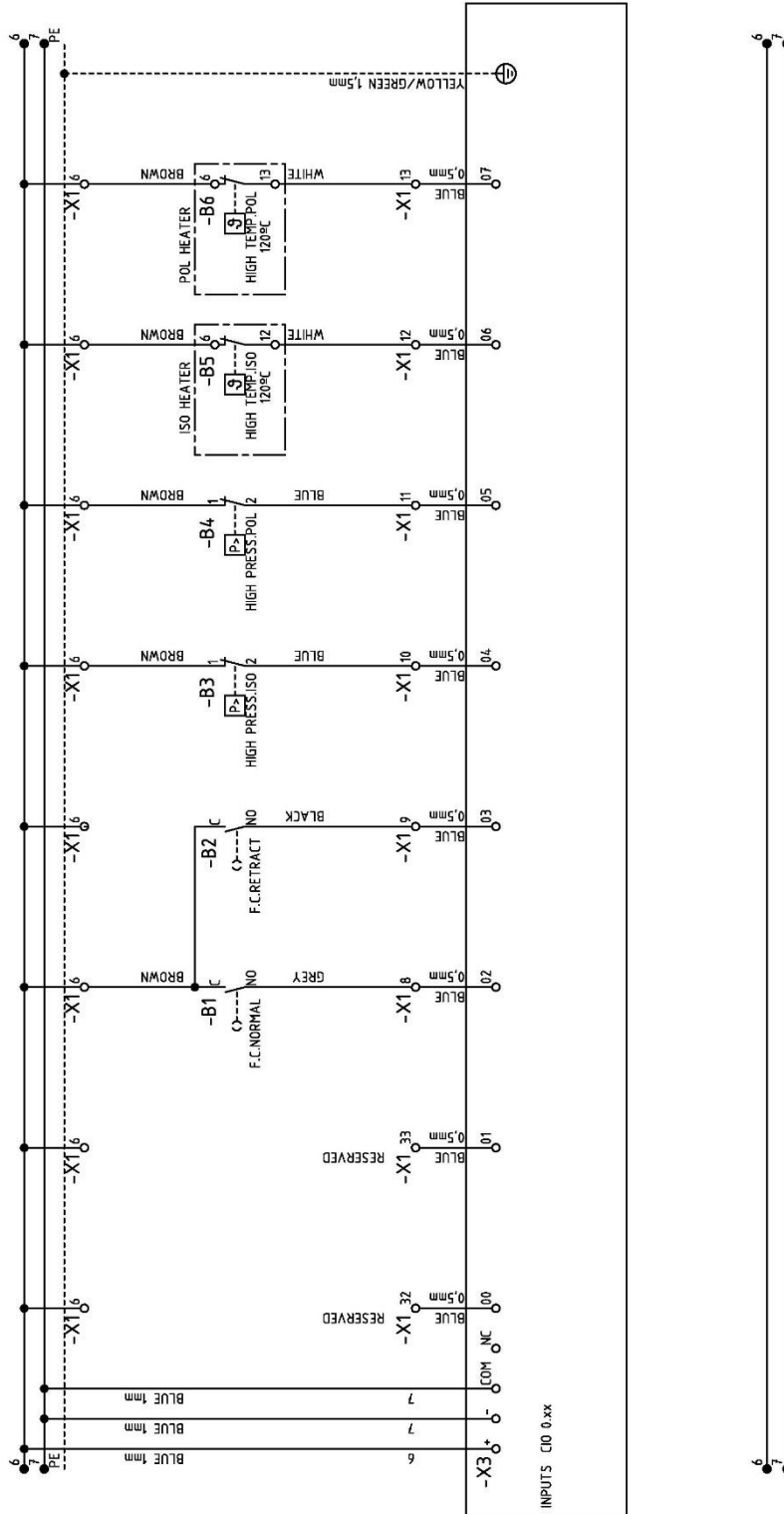

Figure 31. Elec. Schem. 3PE~230V 60Hz Standard Vers. (Sheet 4/12)

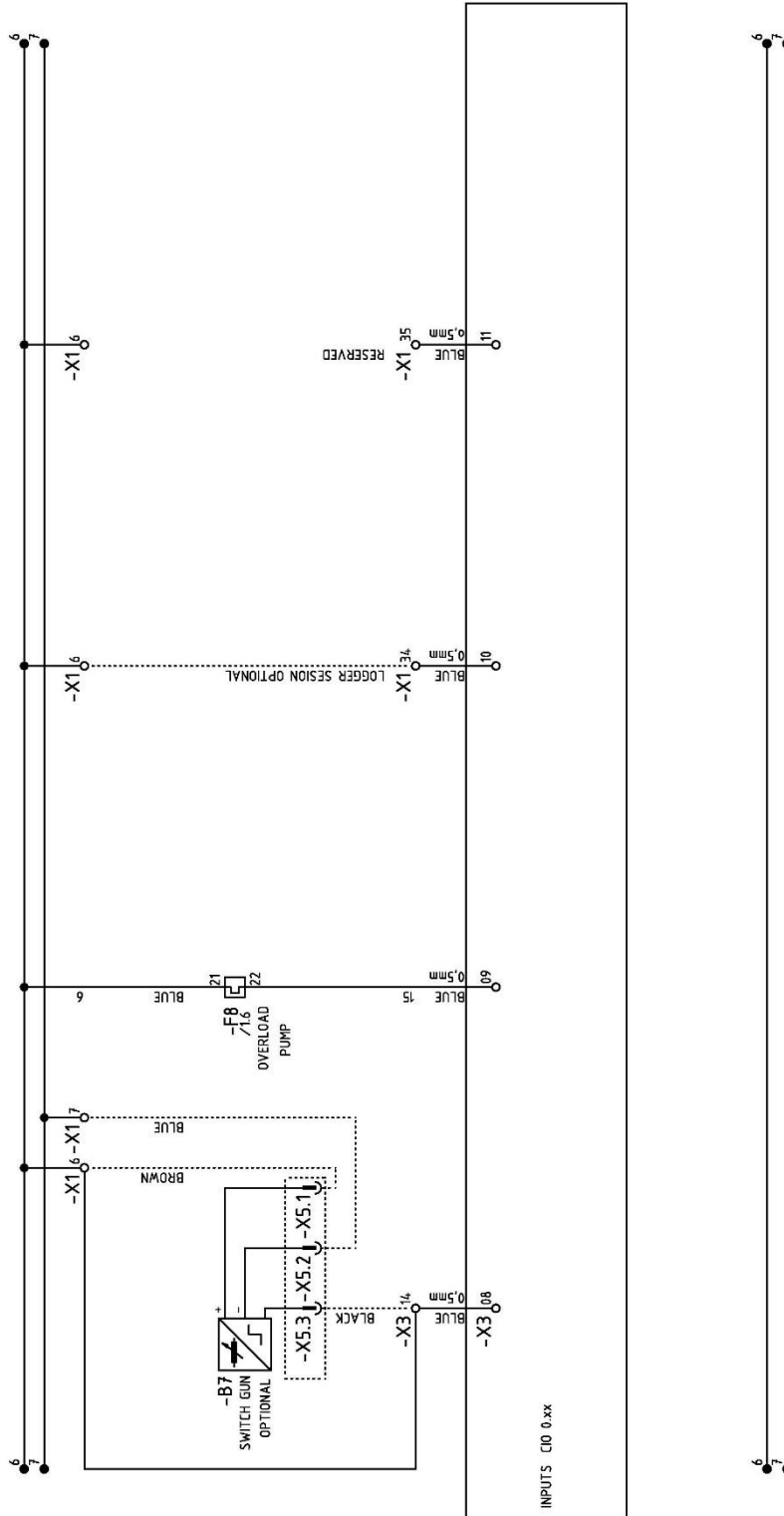

Figure 32. Elec. Schem. 3PE~230V 60Hz Standard Vers. (Sheet 5/12)

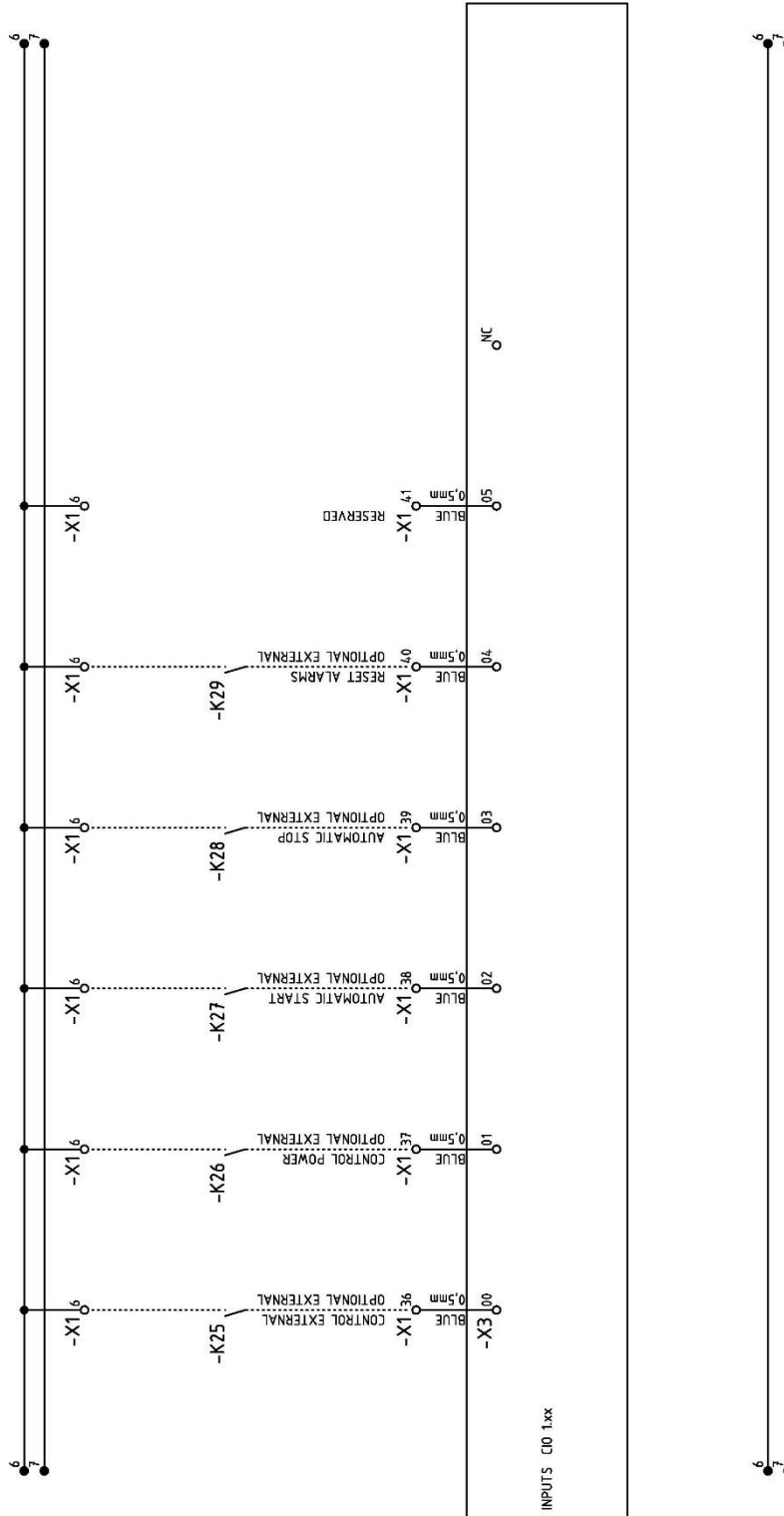

Figure 33. Elec. Schem. 3PE~230V 60Hz Standard Vers. (Sheet 6/12)

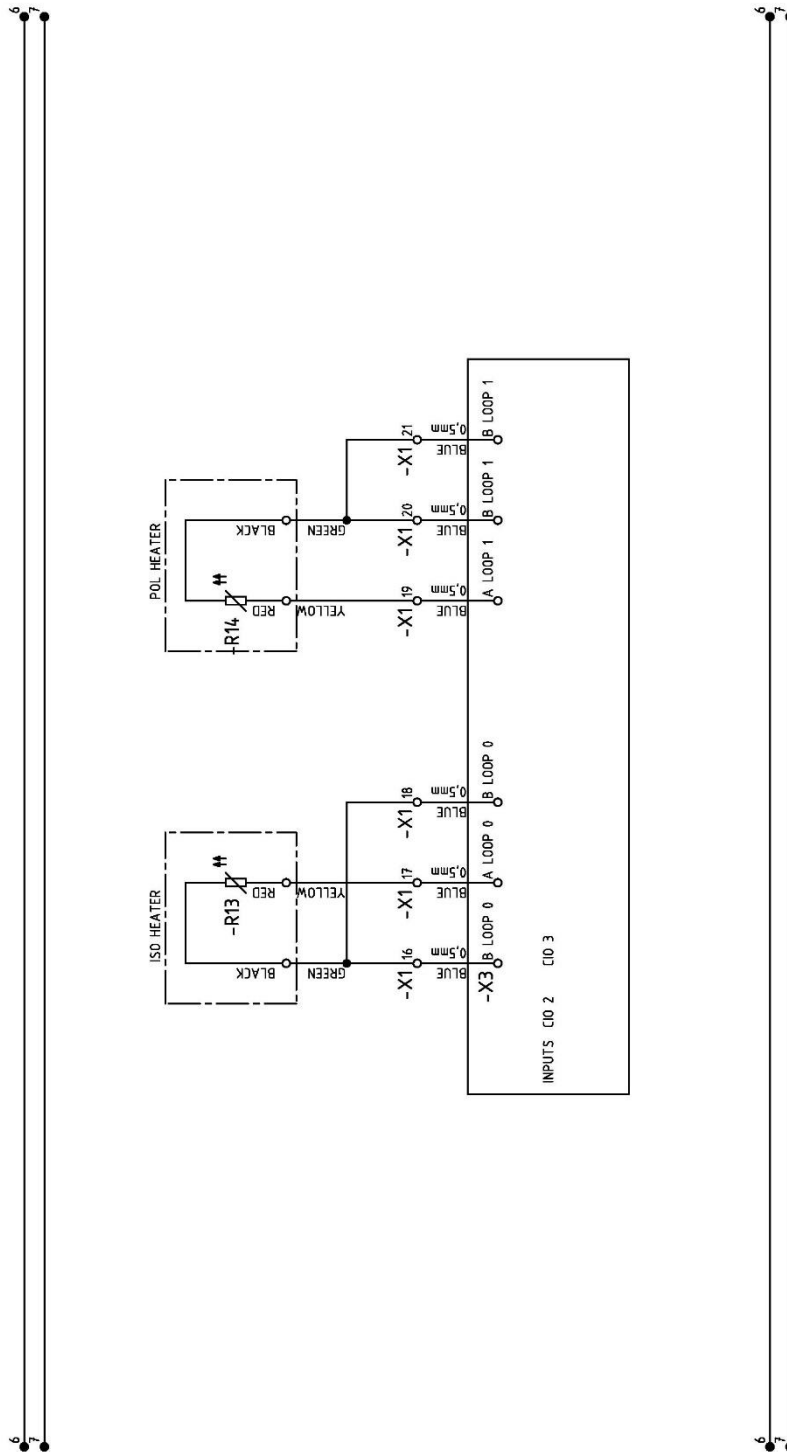

Figure 34. Elec. Schem. 3PE~230V 60Hz Standard Vers. (Sheet 7/12)

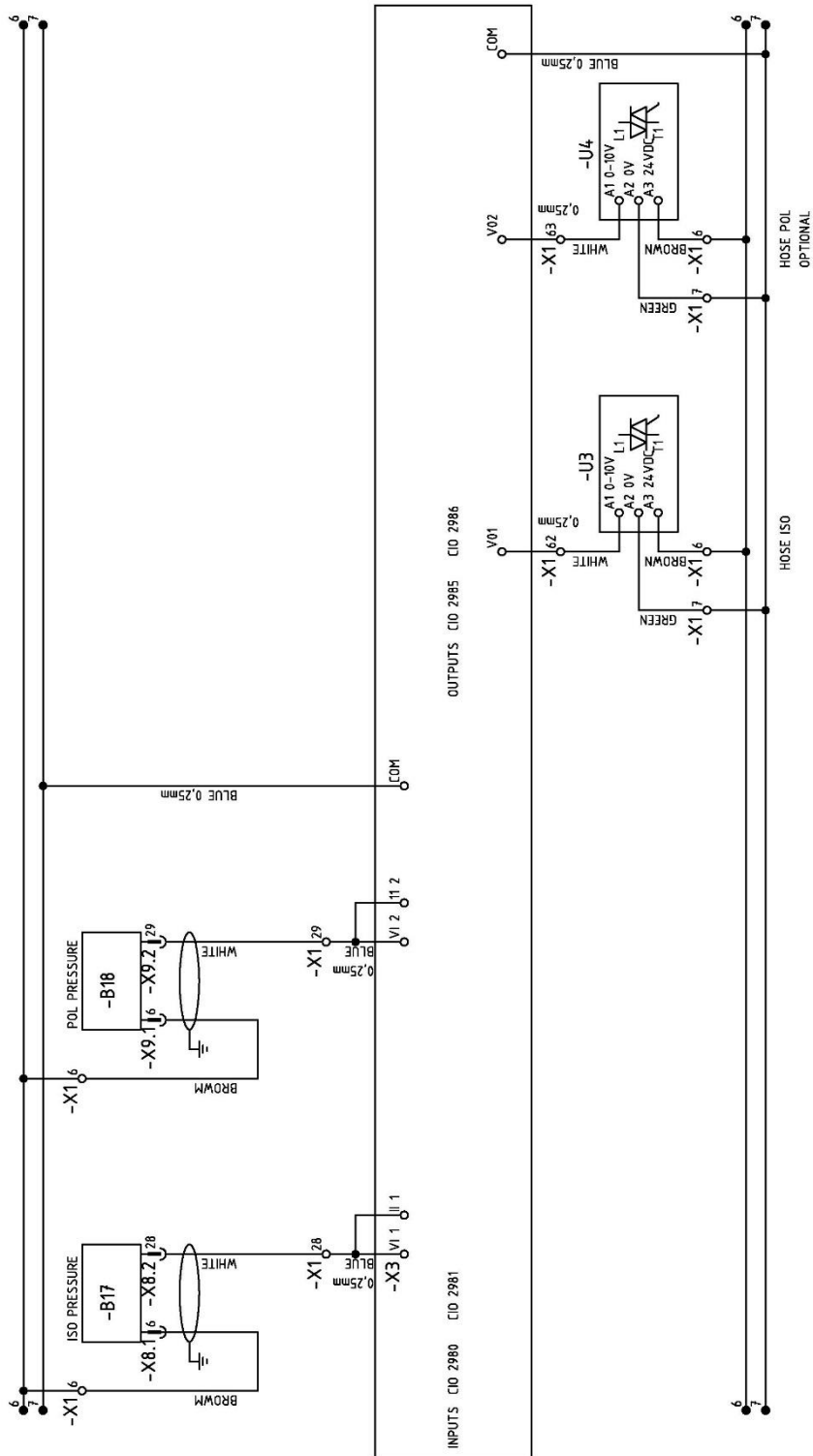

Figure 35. Elec. Schem. 3PE~230V 60Hz Standard Vers. (Sheet 8/12)

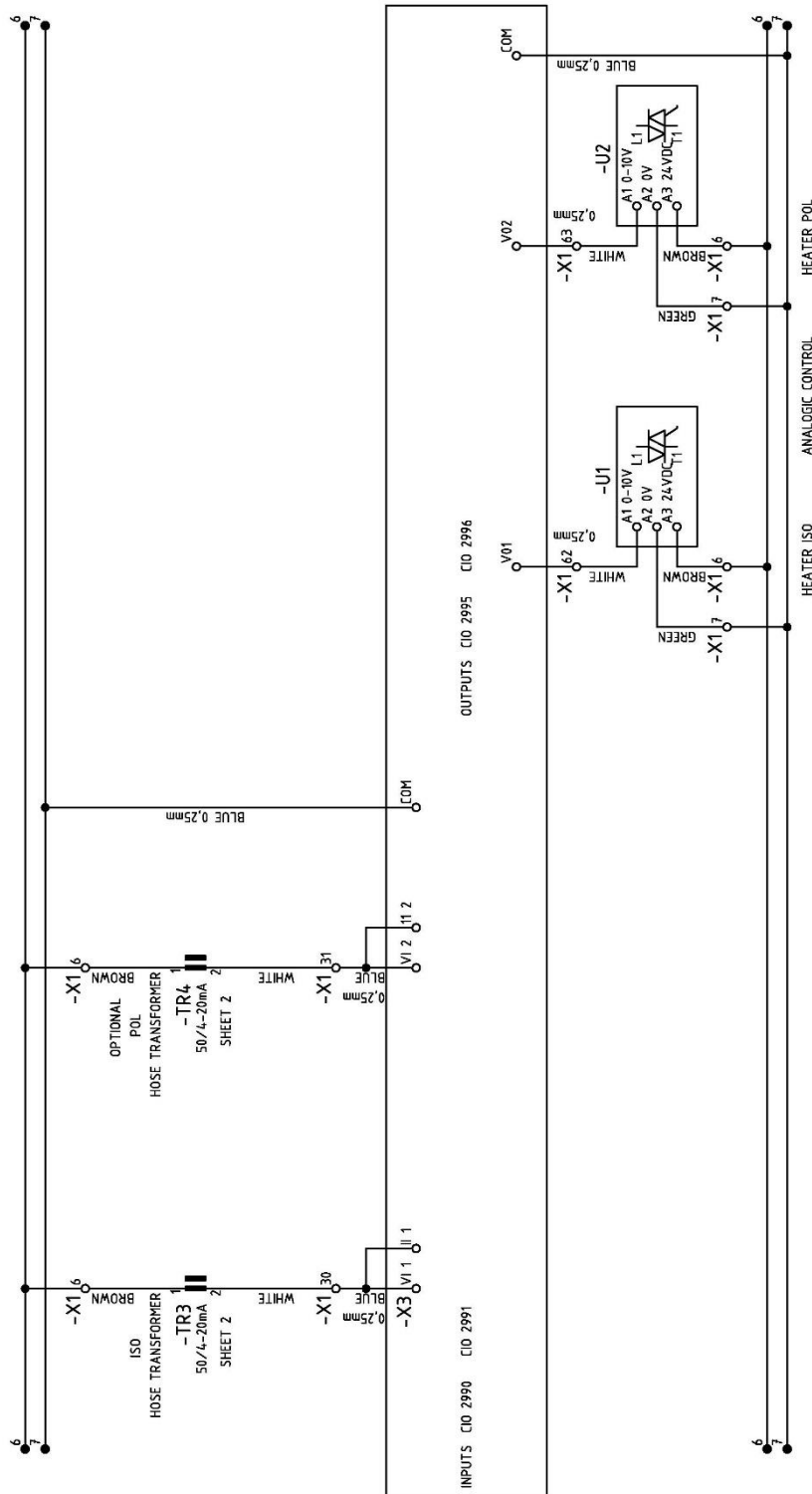

Figure 36. Elec. Schem. 3PE~230V 60Hz Standard Vers. (Sheet 9/12)

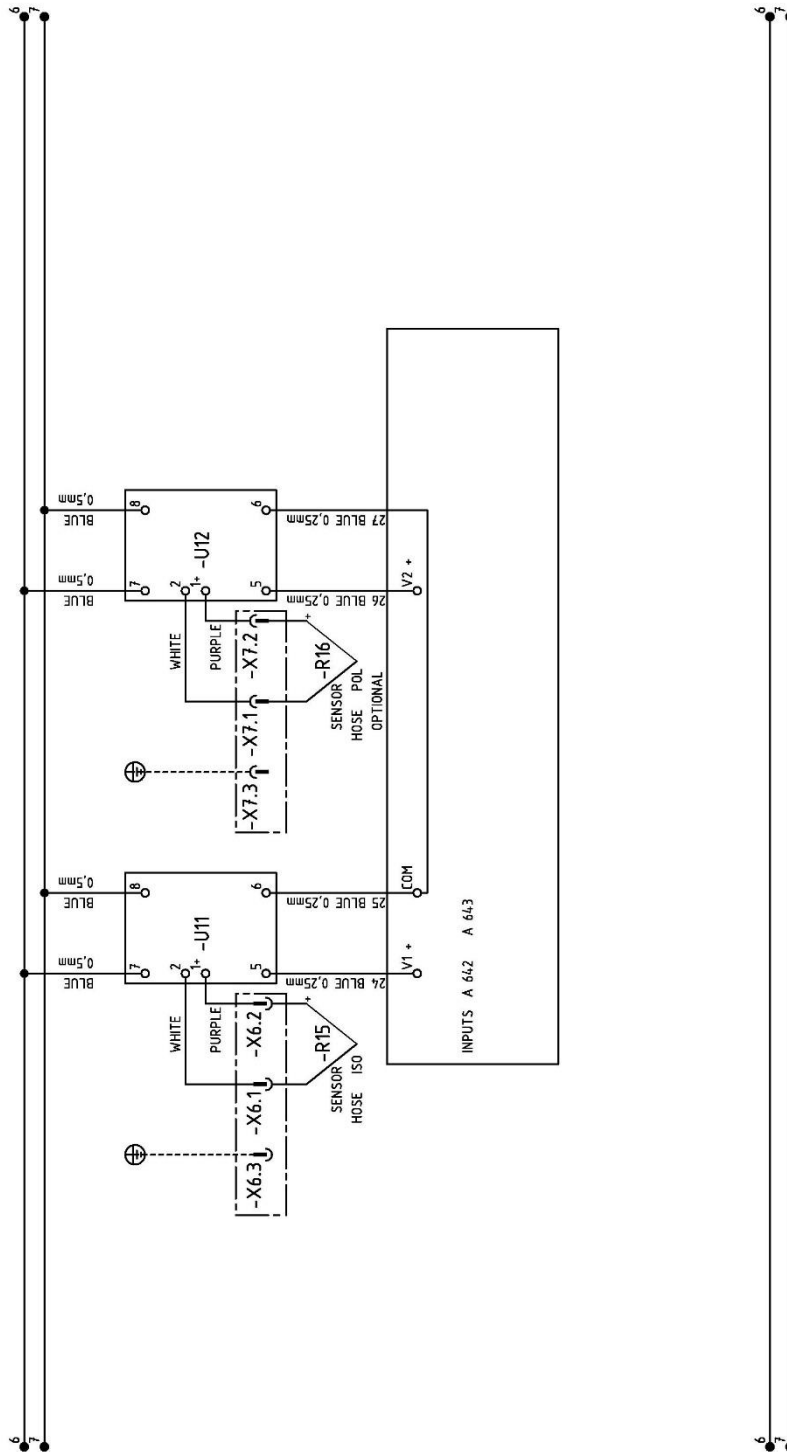

Figure 37. Elec. Schem. 3PE-230V 60Hz Standard Vers. (Sheet 10/12)

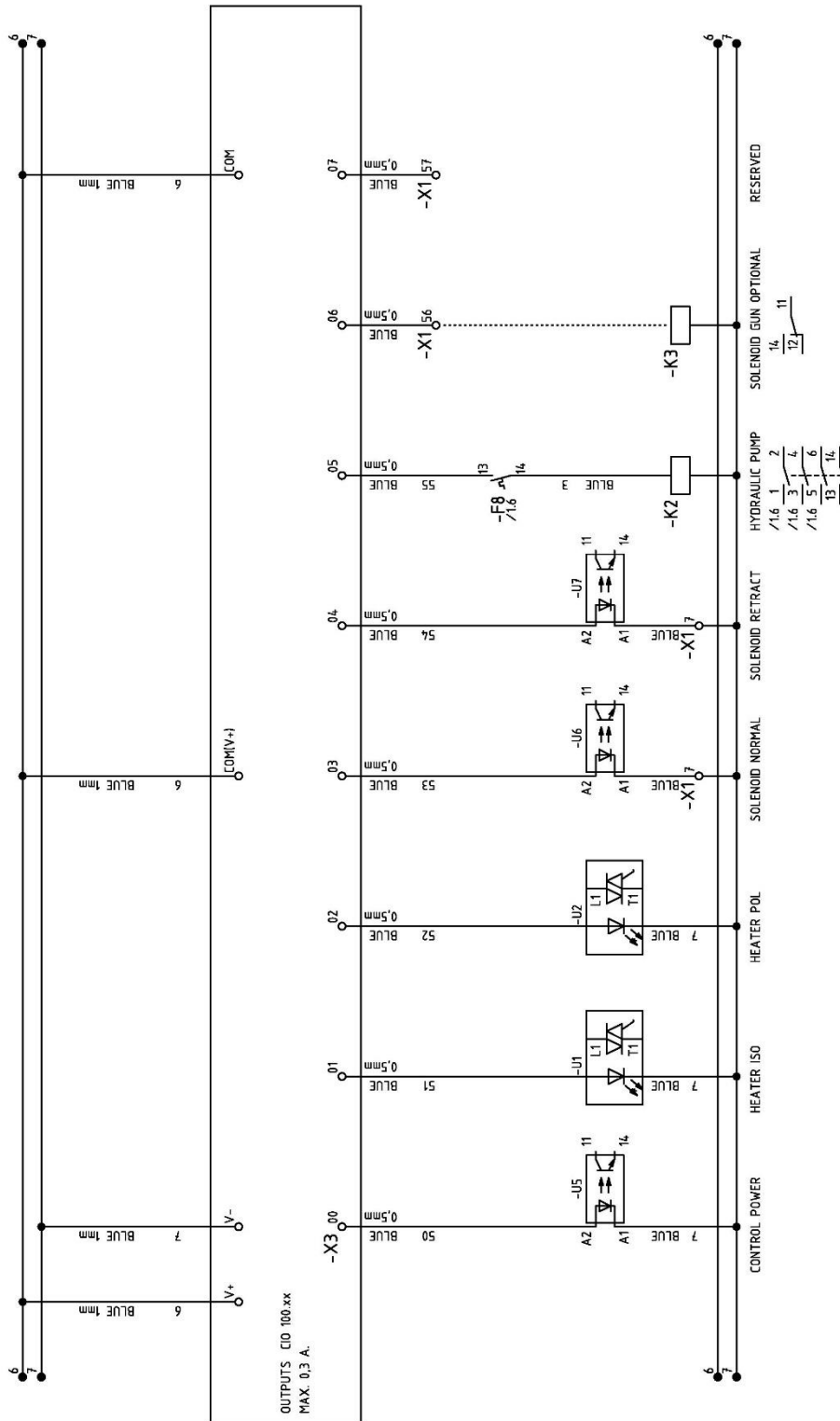

Figure 38. Elec. Schem. 3PE-230V 60Hz Standard Vers. (Sheet 11/12)

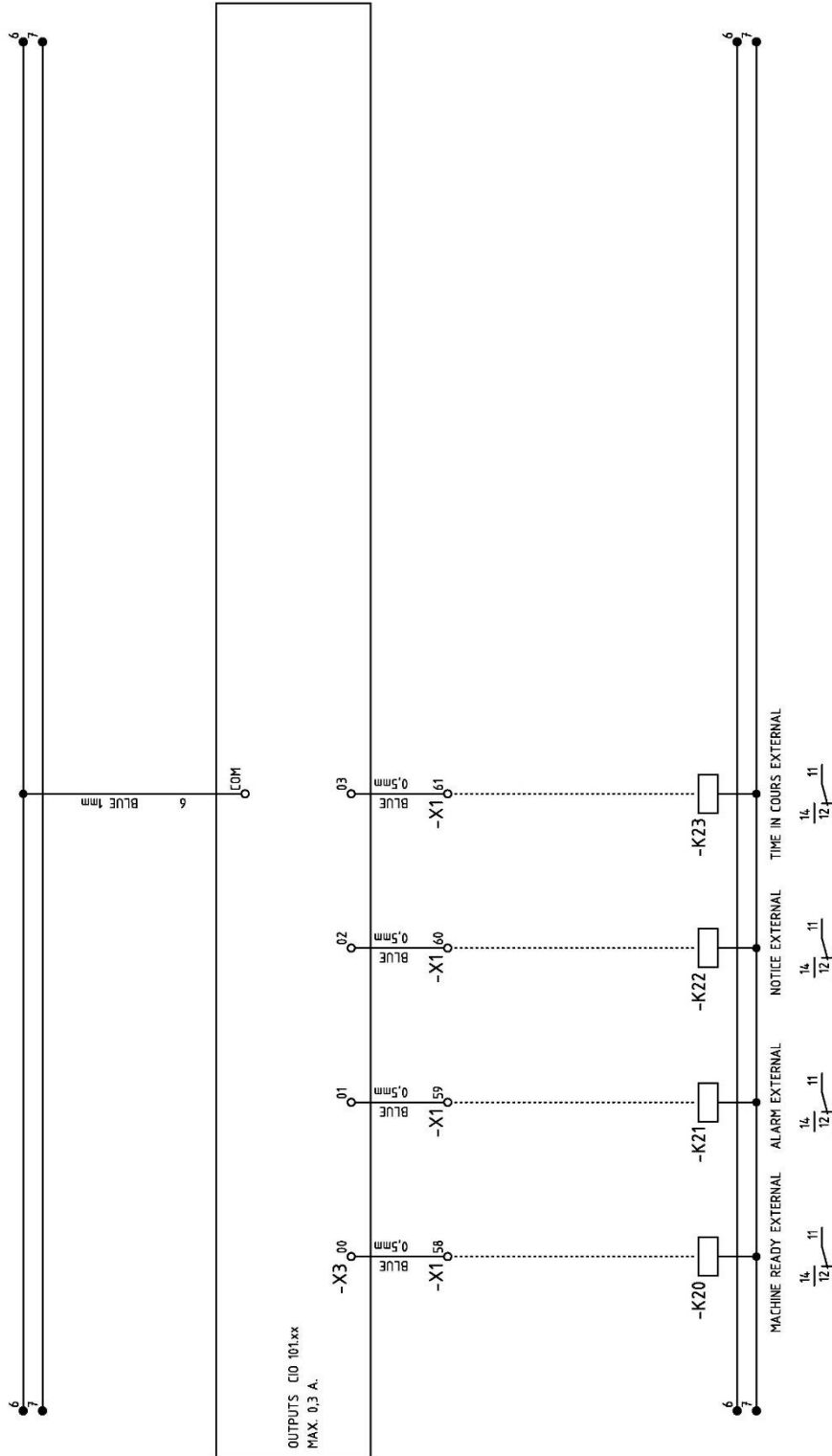

Figure 39. Elec. Schem. 3PE-230V 60Hz Standard Vers. (Sheet 12/12)

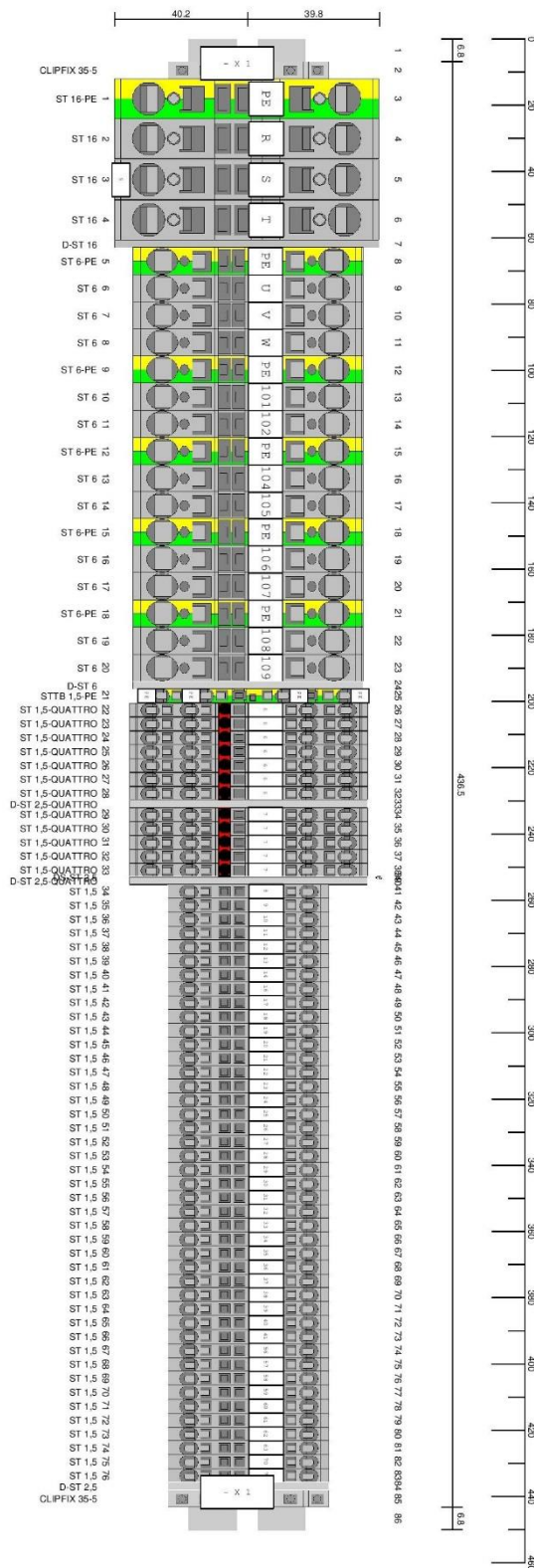
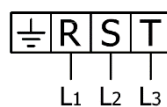

Figure 40. Distribution 3PE~230V 60Hz Standard Version



Table 29. Elec. Schem. 3PE~230V 60Hz Standard Version, Parts List

Item	Description	Reference	Qty
F 10	FUSIBLE POINT	EL-00104-13	1
F 10	FUSE	EL-00128-03	2
I 1	SWITCH 100 A	EL-00107-08	1
I 1	CONTROL RED YELLOW	EL-00107-06	1
G1	POWER SUPPLY 400/24 5 A	EL-00135-03	1
D1	DIFFERENTIAL SWITCH 0,03 80 A	EL-00108-05	1
F 2,3	CIRCUIT BREAKER	EL-00113-03	2
F 4	CIRCUIT BREAKER	EL-00112-12	1
F 1	CIRCUIT BREAKER	EL-00109-04	1
F 5	CIRCUIT BREAKER 10-16A	EL-00119-05	1
F 5	AUXILIARY CONTACTOR	EL-00119-03	1
T 3	INTENSITY TRANSFORMER 50A 4/20mA	EL-00127-19	1
V 1,2	STATIC RELAY	EL-00126-03	2
V 3	TRIAC	EL-00126-11	1
V 3	CONNECTION TRIAC	EL-00126-12	1
K 1	CONTACTOR 24 VDC	EL-00123-02	1
K 2	CONTACTOR 24 VDC	EL-00121-02	1
X 1	TERMINAL STRIP	EL-00105-13	1
	BASE STATIC RELAY	EL-00126-07	3
	STATIC RELAY	EL-00126-06	3
	CPU	EL-00171-03	1
	ANALOGIC MODULE 2E 2S	EL-00171-05	1
	ANALOGIC MODULE 2E	EL-00171-04	1
	EXPANSION MODULE 2EPt100	EL-00171-06	1
	SWITCH 5x ETHERNET	EL-00171-07	1
	TOUCH SCREEN 7"	EL-00171-02	1
	WIRE ETHERNET	EL-00171-09	1
	WIRE ETHERNET	EL-00171-11	1
	MINI MCR-TC-UI-NC	EL-00164-02	1
	USB PORT	EL-00078-06	1
	CONSOLE 500x500	EL-	1
	VENTILATION DEVICE	EL-00158-05	1



3PE~230V 60Hz



PNEUMATIC SCHEMATIC DIAGRAM

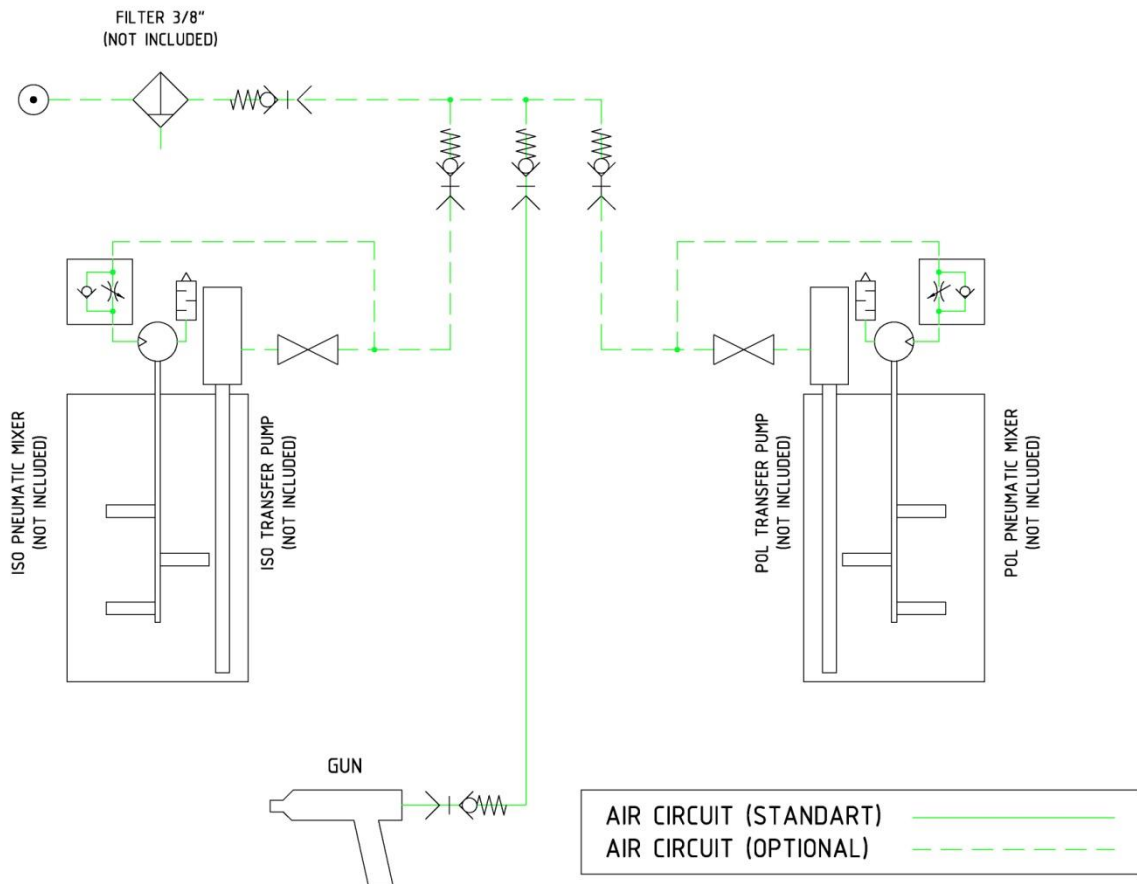

Figure 41. Pneumatic Schematic Diagram



HYDRAULIC SCHEMATIC DIAGRAM

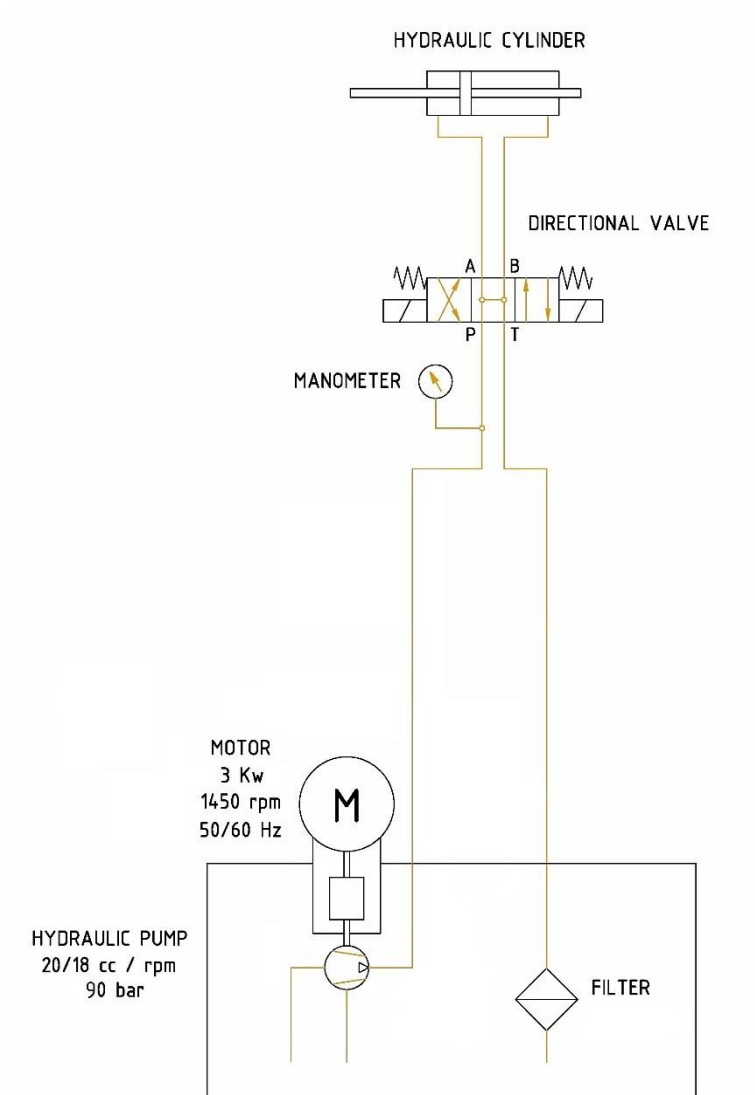

Figure 42. Hydraulic Schematic Diagram



FUNCTIONING SCHEMATIC DIAGRAM

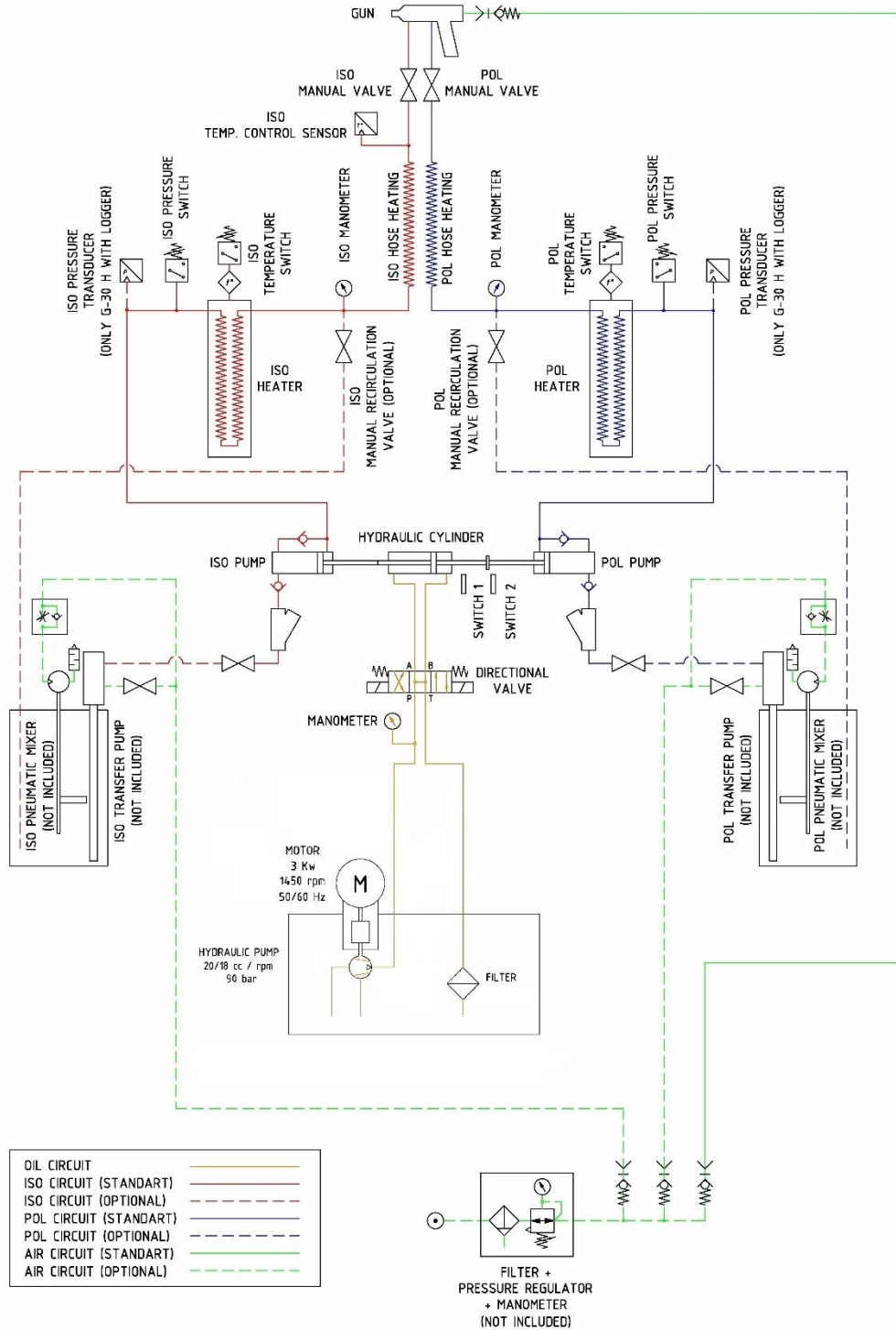

Figure 43. Functioning Schematic Diagram



TABLE OF CONTENTS

Warranty	2
Proportioning Unit novaG III PLUS Model	3
Electrical Console	6
Hydraulic Manifold with Motor 3PE~400V/230V 50/60hz (hyd. Pump 18 cc.)	8
Hydraulic Manifold with Motor 3PE~400V/230V 50/60hz (hyd. Pump 20 cc.)	9
Reversing Switch & Pump Line Support	13
Lube Reservoir Hose Assembly	15
Pump Line Assembly	17
Hydraulic Cylinder with Spacers	20
“A” Proportioning Pump Assembly	22
“R” Proportioning Pump Assembly	25
“A” Standard Primary Heater	28
“R” Standard Primary Heater	31
Recirculation Kit P#: KT-00038	34
Recirculation Kit P#: KT-00038-01	35
Recirculation Kit P#: KT-00038-03	37
Electrical Schematic Diagram 3PE~400V 50/60hz	39
Electrical Schematic Diagram 3PE~230V 60hz	53
Pneumatic Schematic Diagram	67
Hydraulic Schematic Diagram	68
Functioning Schematic Diagram	69
Table of Contents	70
List of Tables	71
List of Illustrations	72



LIST OF TABLES

Table 1. Proportioning Unit novaG III PLUS Model, Parts List	4
Table 2. Hose Transformer Reference List	4
Table 3. A-Primary Heater Reference List	5
Table 4. R-Primary Heater Reference List	5
Table 5. Electrical Console Reference List	5
Table 6. Electrical Console novaG III PLUS Model, Parts List	7
Table 7. Hydraulic Manifold with Motor 3PE~400V/230V 50/60Hz, Parts List	10
Table 8. Reversing Switch & Pump Line Support, Parts List	14
Table 9. Lube Reservoir Hose Assembly, Parts List	16
Table 10. Pump Line Assembly, Parts List	18
Table 11. Proportioning Pump Size, Parts	19
Table 12. Hydraulic Cylinder with Spacers, Parts List	21
Table 13. "A" Proportioning Pump Assembly, Parts List	23
Table 14. "A" Proportioning Pump Assembly, Parts List	24
Table 15. Seals Monobloc "A" Pump	24
Table 16. Repair Seal Kit "A" Pump	24
Table 17. "R" Proportioning Pump Assembly, Parts List	26
Table 18. "R" Proportioning Pump Assembly, Parts List	27
Table 19. Seals Monobloc "R" Pump	27
Table 20. Repair Seal Kit "R" Pump	27
Table 21. "A" Standard Primary Heater, Parts List	29
Table 22. "A" Heat Resistance & Press. Gauge Reference List	30
Table 23. "R" Standard Primary Heater, Parts List	32
Table 24. "R" Heat Resistance & Press. Gauge Reference List	33
Table 25. Standard Recirculation Kit, Parts List	34
Table 26. Recirculation Kit #KT-00038-01, Parts List	36
Table 27. Recirculation Kit #KT-00038-03, Parts List	38
Table 28. Elec. Schem. 3PE~400V 50/60Hz Standard Vers. Parts List	52
Table 29. Elec. Schem. 3PE~230V 60Hz Standard Version, Parts List	66



LIST OF ILLUSTRATIONS

Figure 1. Electrical Console novaG III PLUS	6
Figure 2. Hydraulic Manifold 3PE~400V/230V 50/60Hz (hyd. Pump 18 cc), Exploded View	8
Figure 3. Hydraulic Manifold 3PE~400V/230V 50/60Hz (hyd. Pump 20 cc), Exploded View	9
Figure 4. Reversing Switch & Pump Line Support, Exploded View	13
Figure 5. Lube Reservoir Hose Assembly, Exploded View	15
Figure 6. Pump Line Assembly, Exploded View	17
Figure 7. Hydraulic Cylinder with Spacers, Exploded View	20
Figure 8. "A" Proportioning Pump Assembly, Exploded View	22
Figure 9. "R" Proportioning Pump Assembly, Exploded View	25
Figure 10. "A" Standard Primary Heater, Exploded View	28
Figure 11. "R" Standard Primary Heater, Exploded View	31
Figure 12. Recirculation Kit P#: KT-00038, Exploded View	34
Figure 13. Recirculation Kit P#: KT-00038-01, Exploded View	35
Figure 14. Recirculation Kit P#: KT-00038-03, Exploded View	37
Figure 15. Elec. Schem. 3PE~400V 50/60Hz Standard Vers. (Sheet 1/12)	39
Figure 16. Elec. Schem. 3PE~400V 50/60Hz Standard Vers. (Sheet 2/12)	40
Figure 17. Elec. Schem. 3PE~400V 50/60Hz Standard Vers. (Sheet 3/12)	41
Figure 18. Elec. Schem. 3PE~400V 50/60Hz Standard Vers. (Sheet 4/12)	42
Figure 19. Elec. Schem. 3PE~400V 50/60Hz Standard Vers. (Sheet 5/12)	43
Figure 20. Elec. Schem. 3PE~400V 50/60Hz Standard Vers. (Sheet 6/12)	44
Figure 21. Elec. Schem. 3PE~400V 50/60Hz Standard Vers. (Sheet 7/12)	45
Figure 22. Elec. Schem. 3PE~400V 50/60Hz Standard Vers. (Sheet 8/12)	46
Figure 23. Elec. Schem. 3PE~400V 50/60Hz Standard Vers. (Sheet 9/12)	47
Figure 24. Elec. Schem. 3PE~400V 50/60Hz Standard Vers. (Sheet 10/12)	48
Figure 25. Elec. Schem. 3PE~400V 50/60Hz Standard Vers. (Sheet 11/12)	49
Figure 26. Elec. Schem. 3PE~400V 50/60Hz Standard Vers. (Sheet 12/12)	50
Figure 27. Distribution 3PE~400V 50/60Hz Standard Version	51
Figure 28. Elec. Schem. 3PE~230V 60Hz Standard Vers. (Sheet 1/12)	53
Figure 29. Elec. Schem. 3PE~230V 60Hz Standard Vers. (Sheet 2/12)	54
Figure 30. Elec. Schem. 3PE~230V 60Hz Standard Vers. (Sheet 3/12)	55
Figure 31. Elec. Schem. 3PE~230V 60Hz Standard Vers. (Sheet 4/12)	56
Figure 32. Elec. Schem. 3PE~230V 60Hz Standard Vers. (Sheet 5/12)	57
Figure 33. Elec. Schem. 3PE~230V 60Hz Standard Vers. (Sheet 6/12)	58
Figure 34. Elec. Schem. 3PE~230V 60Hz Standard Vers. (Sheet 7/12)	59



Figure 35. Elec. Schem. 3PE~230V 60Hz Standard Vers. (Sheet 8/12)	60
Figure 36. Elec. Schem. 3PE~230V 60Hz Standard Vers. (Sheet 9/12)	61
Figure 37. Elec. Schem. 3PE~230V 60Hz Standard Vers. (Sheet 10/12)	62
Figure 38. Elec. Schem. 3PE~230V 60Hz Standard Vers. (Sheet 11/12)	63
Figure 39. Elec. Schem. 3PE~230V 60Hz Standard Vers. (Sheet 12/12)	64
Figure 40. Distribution 3PE~230V 60Hz Standard Version	65
Figure 41. Pneumatic Schematic Diagram	67
Figure 42. Hydraulic Schematic Diagram	68
Figure 43. Functioning Schematic Diagram	69