

Parts Manual

Spray Gun

novaG-A Series

Issue 2.1 28/07/2020
Ref. NR-00015-ENG



Before starting or doing maintenance on the novaG-A gun, carefully read all of the technical and safety documentation included in the Service Manual. Special attention should be paid to the information for knowing and understanding the handling and conditions of use of the gun. This information is aimed at USER SAFETY and the PREVENTION OF PROBLEMS.



GUARANTEE

HI-TECH SPRAY EQUIPMENT, S. A. (hereinafter "HI-TECH") grants this Guarantee limited to the original purchaser (hereinafter "Client") for the equipment and the original accessories delivered with the equipment (hereinafter "Product") against any fault in design, materials or manufacture of the Product at the time of the first purchase by the users and for a period of two (2) years there from.

If during the guarantee period and under normal conditions of use, the Product should fail to work correctly due to defects of design, material or manufacture, the authorised distributor of the country where the HI-TECH Product or technical assistance service has been purchased shall repair or replace the Product in accordance with what is established in the following

CONDITIONS

- a) The validity of this guarantee will be subject to the presentation of the original invoice issued by the HI-TECH authorised distributor for the sale of the Product along with the Product handed over for repair or replacement, which must show the date of purchase and the serial number. HI-TECH reserves the right to refuse to give the guarantee service when the indicated data fail to appear on the invoice or have been modified after the purchase of the Product.
- b) The repaired or replaced Product will continue to maintain the original guarantee for the time remaining until the end of the guarantee or for three (3) months from the repair date, if the remaining period of the original guarantee were shorter.
- c) This guarantee will not be applied to the faults in the Product caused by its faulty installation, the natural wear and tear of the components, any use other than that considered normal for this Product or which should fail to strictly comply with the instructions of use provided by HI-TECH; due to accident, carelessness, adjustments, alterations or modifications of the Product not authorised by HI-TECH or due to the use of accessories, heating devices, pumping equipment and/or dispensers that have not been approved or manufactured by HI-TECH.
- d) The guarantee applicable to the components and accessories forming part of the Product and which have not been made by HI-TECH will be limited to the guarantee offered by the original manufacturer thereof.

HI-TECH WILL NOT RECOGNISE ANY EXPRESS ORAL OR WRITTEN GUARANTEES OTHER THAN THIS PRINTED LIMITED GUARANTEE. ALL IMPLICIT GUARANTEES, INCLUDING, WITHOUT LIMIT, ADAPTATION FOR A SPECIFIC USE, ARE SUBJECT TO THE DURATION OF THIS WRITTEN GUARANTEE. HI-TECH DOES NOT ASSUME ANY KIND OF COMMITMENT OR RESPONSIBILITY FOR ALL POSSIBLE DAMAGE OR EXPENSE CAUSED BY FAULTS IN THE OUTPUT OF THE PRODUCT, ITS WORKING OR THE DISPENSING OF MATERIAL THROUGH THE PRODUCT, INCLUDING, WITHOUT LIMITATION, ALL EXPENSES CAUSED BY DAMAGE TO PEOPLE OR PROPERTY. EQUALLY, HI-TECH WILL IN NO CASE ACCEPT LIABILITY FOR THE LOSS OF SPECULATIVE PROFITS OR COMMERCIAL LOSSES. ALL REPAIRS OR REPLACEMENT OF FAULTY PRODUCTS WILL CONSTITUTE THE COMPREHENSIVE FULFILMENT OF HI-TECH'S OBLIGATIONS WITH RESPECT TO THE CLIENT. HI-TECH DOES NOT IN ANY WAY GUARANTEE THE SUITABILITY OR APTITUDE OF ITS PRODUCT FOR ANY PARTICULAR PURPOSE OR APPLICATION.

All of the information provided on components which have not been manufactured by HI-TECH and which is based on reports received from the original manufacturer, though considered precise and reliable, is provided without any guarantee or responsibility of any explicit or implicit kind.

All concession, sale or financial leasing of the Product by HI-TECH in no case explicitly or implicitly constitutes any authorisation, acceptance or concession for the use of any rights or patents, nor does it encourage, nurture or back their infringement.

The restrictions on the guarantee suppose no limitation on the legal rights of the consumer established in applicable national legislation, nor do they affect any rights derived from the bargain and sale agreement between the consumer and supplier.



STANDARD FINAL ASSEMBLY

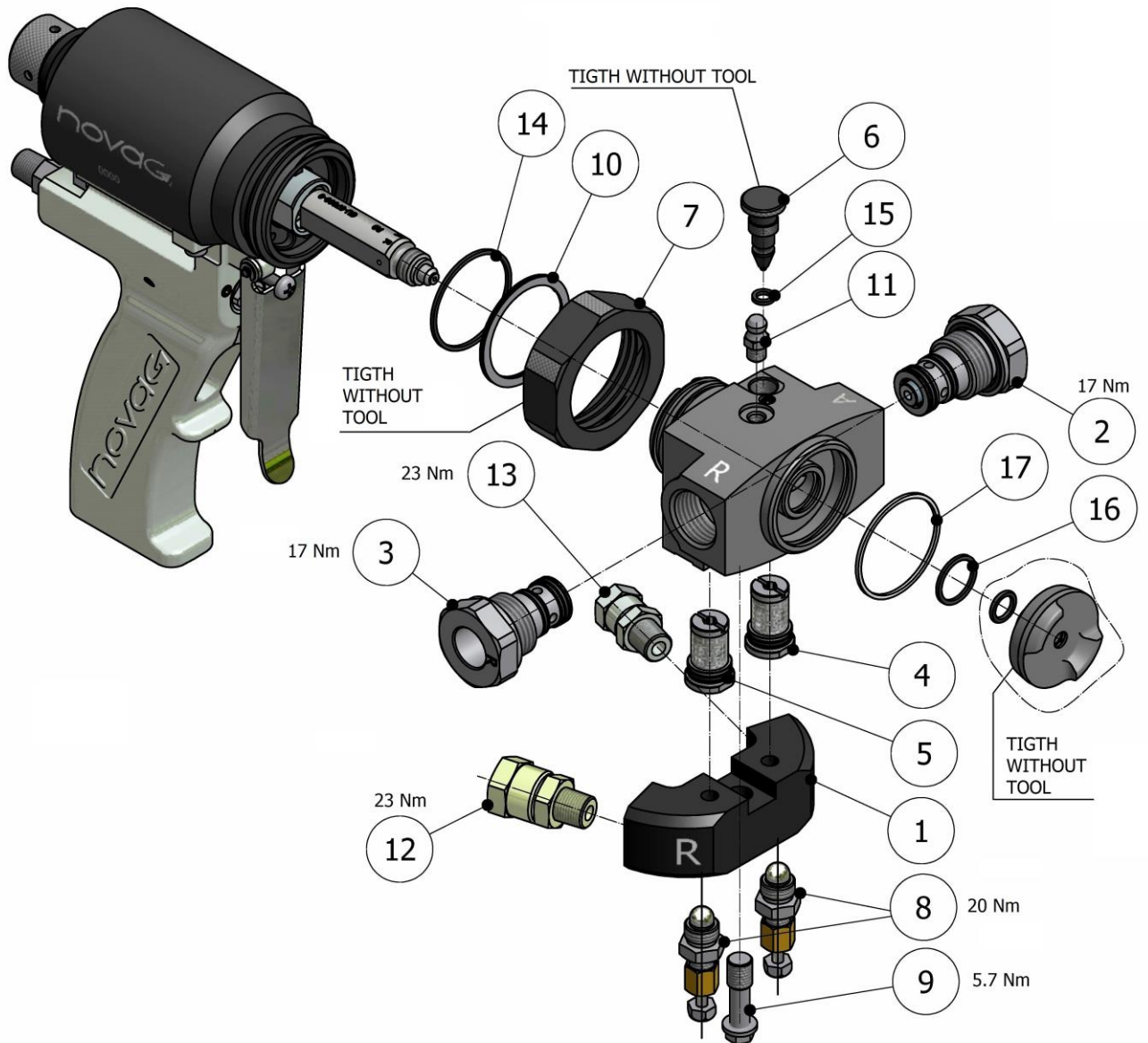

Figure 1. Standard Final Assembly, novaG-A Gun

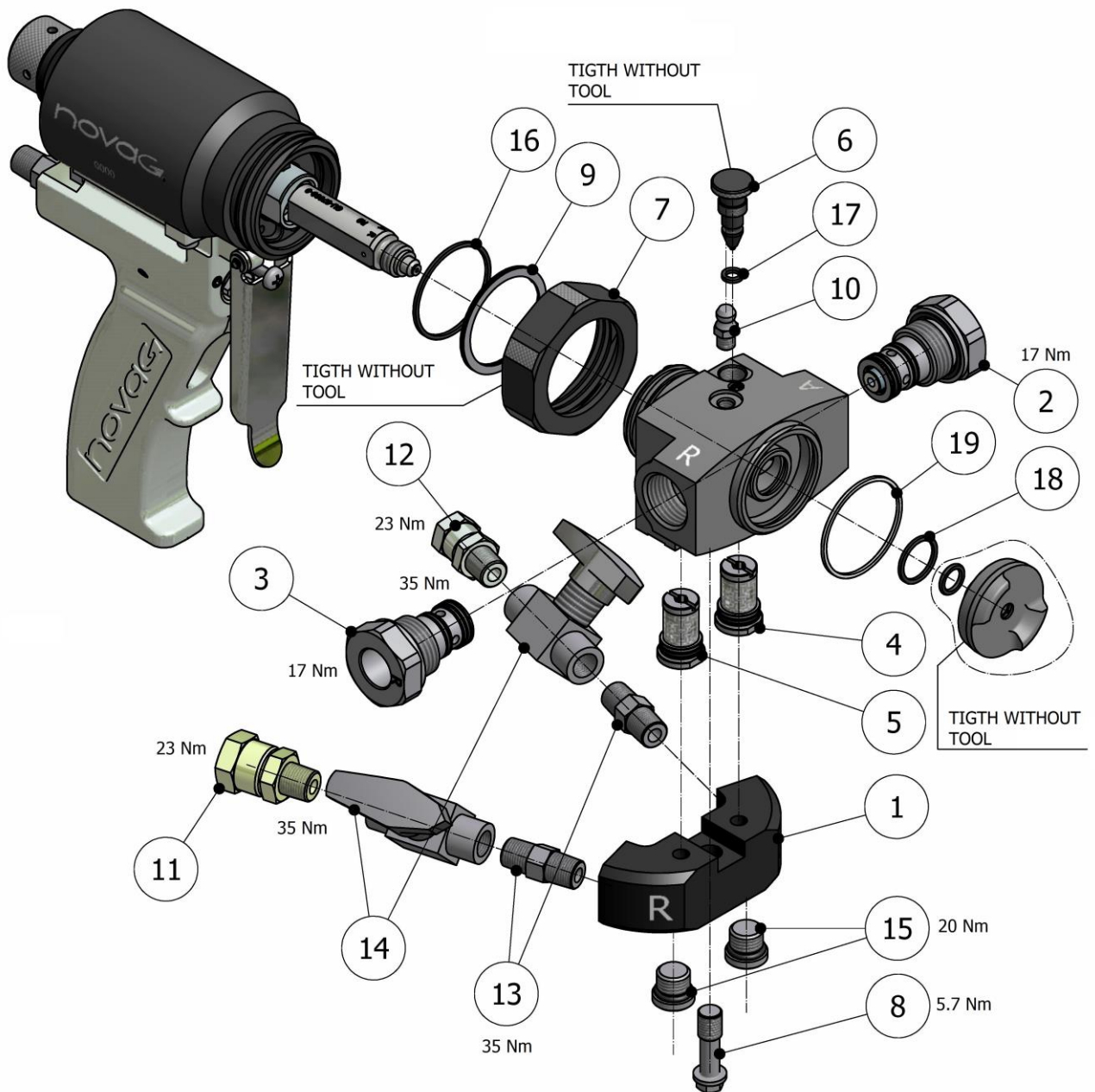

**Table 1. Standard Final Assembly Component List
novaG-A Gun**

Pos.	Description	Reference	Qty.
1	Input Block Unit	GU-02115-00	1
2	Friction Bushing Cartridge Unit "A" ISO	GU-07016	1
3	Friction Bushing Cartridge Unit "R" POL	GU-07018	1
4	Non-Return Unit "A" ISO	GU-07003	1
5	Non-Return Unit "R" POL	GU-07004	1
6	Air Regulator	GU-07023	1
7	Head Throat Nut	GU-07021	1
8	Manual Valve Unit	GU-02020-00G	2
9	Input Block Screw	GU-04036	1
10	Fixing Ring	TN-00315	1
11	Greaser	TN-00292	1
12	Free Nut	RA-00006	1
13	Free Nut	RA-00005	1
14	O-ring	OR-00123	1
15	O-ring	OR-00001	1
16	O-ring	OR-00025	1
17	O-ring	OR-00124	1



BALL VALVE FINAL ASSEMBLY (OPTIONAL)



**Figure 2. Ball Valve Final Assembly (OPTIONAL)
novaG-A Gun**

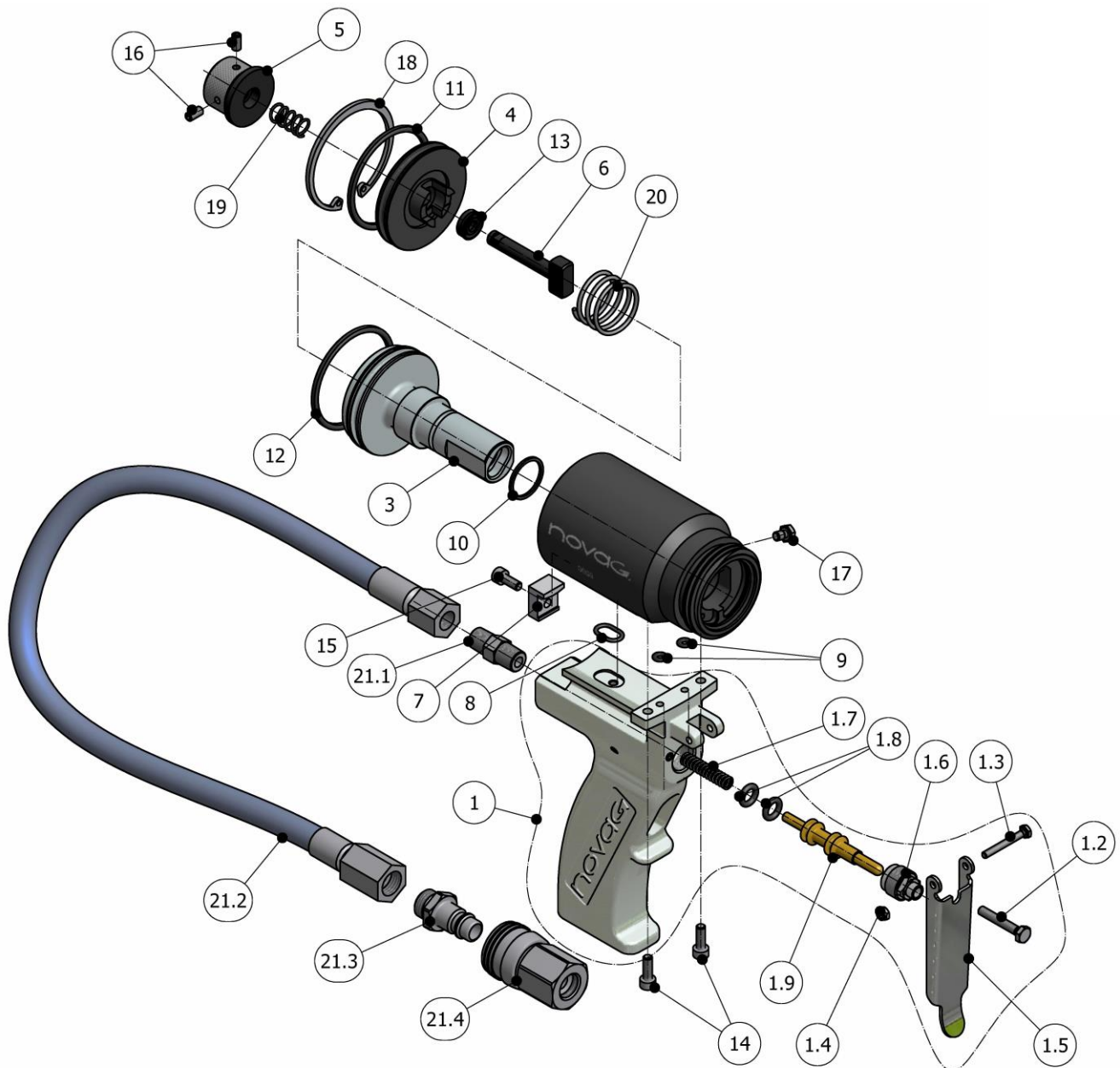

**Table 2. Ball Valve Final Assembly Component List (OPTIONAL)
novaG-A Gun**

Pos.	Description	Reference	Qty.
1	Input Block Unit	GU-02115-00	1
2	Friction Bushing Cartridge Unit "A" ISO	GU-07016	1
3	Friction Bushing Cartridge Unit "R" POL	GU-07018	1
4	Non-Return Unit ISO	GU-07003	1
5	Non-Return Unit POL	GU-07004	1
6	Air Regulator	GU-07023	1
7	Head Throat Nut	GU-07021	1
8	Input Block Screw	GU-04036	1
9	Fixing Ring	TN-00315	1
10	Greaser	TN-00292	1
11	Free Nut	RA-00006	1
12	Free Nut	RA-00005	1
13	Pillar	RA-00112	2
14	High Pressure Ball Cock	RA-00070H	2
15	Stopper	RA-00242	2
16	O-ring	OR-00123	1
17	O-ring	OR-00001	1
18	O-ring	OR-00025	1
19	O-ring	OR-00124	1



AIR CYLINDER AND GRIP ASSEMBLY



**Figure 3. Air Cylinder and Grip Assembly
novaG-A Gun**



**Table 3. Grip and Air Cylinder Component List
novaG-A Gun**

Pos.	Description	Reference	Qty.
1	Handle with Trigger unit	NGU-04001-02	1
1.1	<i>Handle with Stoppers</i>	NGU-04048-01	1 (*)
1.1A	<i>Handle Machined and Polished without Stoppers</i>	NGU-04048-00	1 (*)
1.1B	<i>Stoppers</i>	TN-00251	6 (*)
1.2	<i>Trigger Stop Bolt</i>	TN-00235	1 (*)
1.3	<i>Trigger Screw</i>	TN-00459	1 (*)
1.4	<i>Lock Nut</i>	TN-00460	1 (*)
1.5	<i>Trigger</i>	GU-02132	1 (*)
1.6	<i>Trigger Valve Nut</i>	GU-02131	1 (*)
1.7	<i>Trigger Spring</i>	SP-00022	1 (*)
1.8	<i>O-ring</i>	OR-00079	2 (*)
1.9	<i>Trigger Shaft</i>	GU-02130	1 (*)
2	Double Effect Cylinder Sleeve	NGU-07002	1
3	Plunger	GU-07012	1
4	Cylinder Block	GU-07009	1
5	Block Activator	GU-02007	1
6	Lock Bolt	GU-02008	1
7	Sleeve Staple	GU-02021	1
8	O-ring	OR-00015	1
9	O-ring	OR-00002	2
10	O-ring	OR-00070	1
11	O-ring	OR-00122	1
12	O-ring	OR-00122	1
13	Collar	OR-00027	1
14	Allen Bolt	TN-00049	2
15	Allen Bolt	TN-00002	1
16	Trap	TN-00099	2
17	Hexagonal Screw	TN-00316	1
18	Seeger Ring	TN-00222	1



Parts Manual

Pos.	Description	Reference	Qty.
19	Block Spring	SP-00008	1
20	Plunger Spring	SP-00007	1
21	Pillar	RA-00112	1
22	Air Line	MA-00027	1
23	Fast Connection Pin	RA-00110	1
24	Fast Plug	RA-00109	1

N.B.:

The shaded positions correspond to the subunit codes.

The positions in italics form part of the respective subunits

() Individual quantities for each fitted subunit.*

MAGNETIC MICRO ASSEMBLY (OPTIONAL)

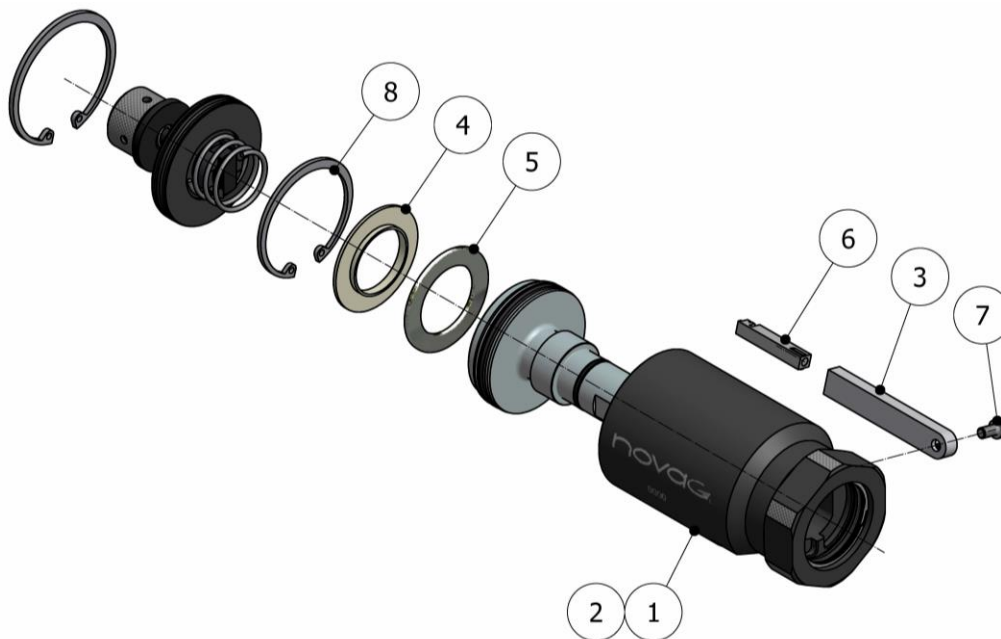

Figure 4. Magnetic Micro Assembly (OPTIONAL)

Table 4. Magnetic Micro Assembly Component List (OPTIONAL)

Pos.	Description	Reference	Qty.
1	Gun Sleeve for Micro	NGU-07002	1
2	Gun Sleeve for Timer-Auto Version Micro	NGU-07002-ATM	1
3	Micro Detector Support	GU-02051	1
4	Magnet Cover	GU-07025	1
5	Neodymium Magnet	GU-07024	1
6	Magnetic detector with 2.5 m cable + 1 square connector.	EL-00136-04	1
7	Allen Bolt	TN-00002	1
8	Seeger Ring	TN-00208	1

N.B.:

Fit the correct Sleeve for the gun version; Standard or Automatic/Timer.



TIMER ASSEMBLY (OPTIONAL)

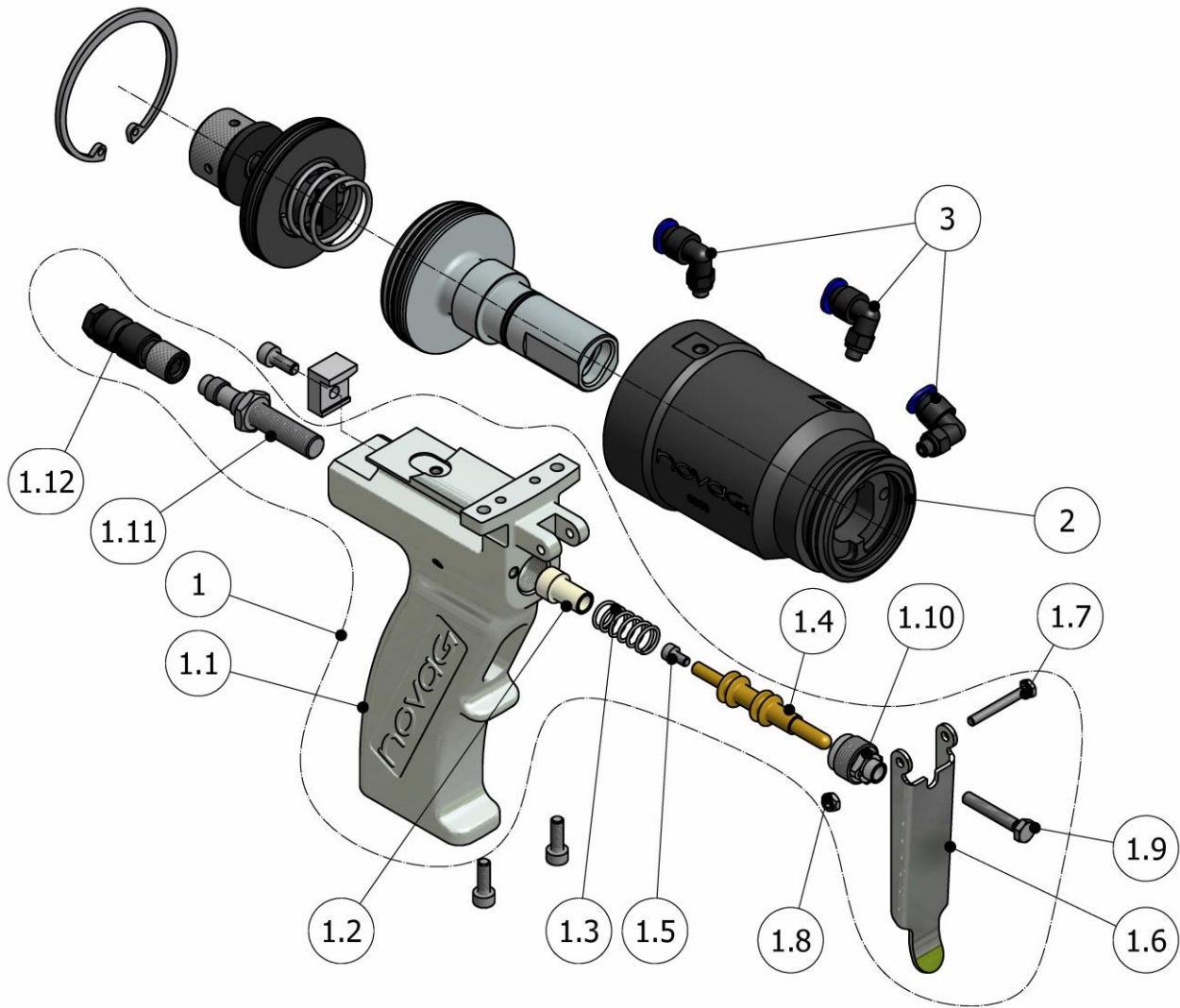

Figure 5. Timer Assembly (OPTIONAL)



Table 5. Timer Assembly Component List (OPTIONAL)

Pos.	Description	Reference	Qty.
1	Set. Handle with Trigger for Timer	NGU-04001-02A	1
1.1	<i>Handle Machined and Polished (*)</i>	<i>NGU-04048-A0</i>	<i>1 (*)</i>
1.2	<i>Timer Spring Seat (*)</i>	<i>GU-02135</i>	<i>1 (*)</i>
1.3	<i>Timer Trigger Spring (*)</i>	<i>SP-00023</i>	<i>1 (*)</i>
1.4	<i>Trigger Shaft for Timer (*)</i>	<i>GU-02130-A</i>	<i>1 (*)</i>
1.5	<i>Allen bolt (*)</i>	<i>TN-00020</i>	<i>1 (*)</i>
1.6	<i>Trigger (*)</i>	<i>GU-02132</i>	<i>1 (*)</i>
1.7	<i>Trigger Screw (*)</i>	<i>TN-00459</i>	<i>1 (*)</i>
1.8	<i>Lock Nut (*)</i>	<i>TN-00460</i>	<i>1 (*)</i>
1.9	<i>Trigger Stop Bolt (*)</i>	<i>TN-00235</i>	<i>1 (*)</i>
1.10	<i>Trigger Nut (*)</i>	<i>GU-02131</i>	<i>1 (*)</i>
1.11	<i>Inductive Detector (*)</i>	<i>EL-00136-02</i>	<i>1 (*)</i>
1.12	<i>Detector Cable with Connectors (*)</i>	<i>EL-00137-02</i>	<i>1 (*)</i>
2	Timer Version Gun Sleeve	NGU-07002-ATM	1
3	Knead Pneumatic Connection	RA-00088	3

N.B.:

The shaded positions correspond to the subunit codes.

The positions in italics form part of the respective subunits

(*) Individual quantities for each fitted subunit.



ASSEMBLY FOR AUTO VERSION (OPTIONAL)

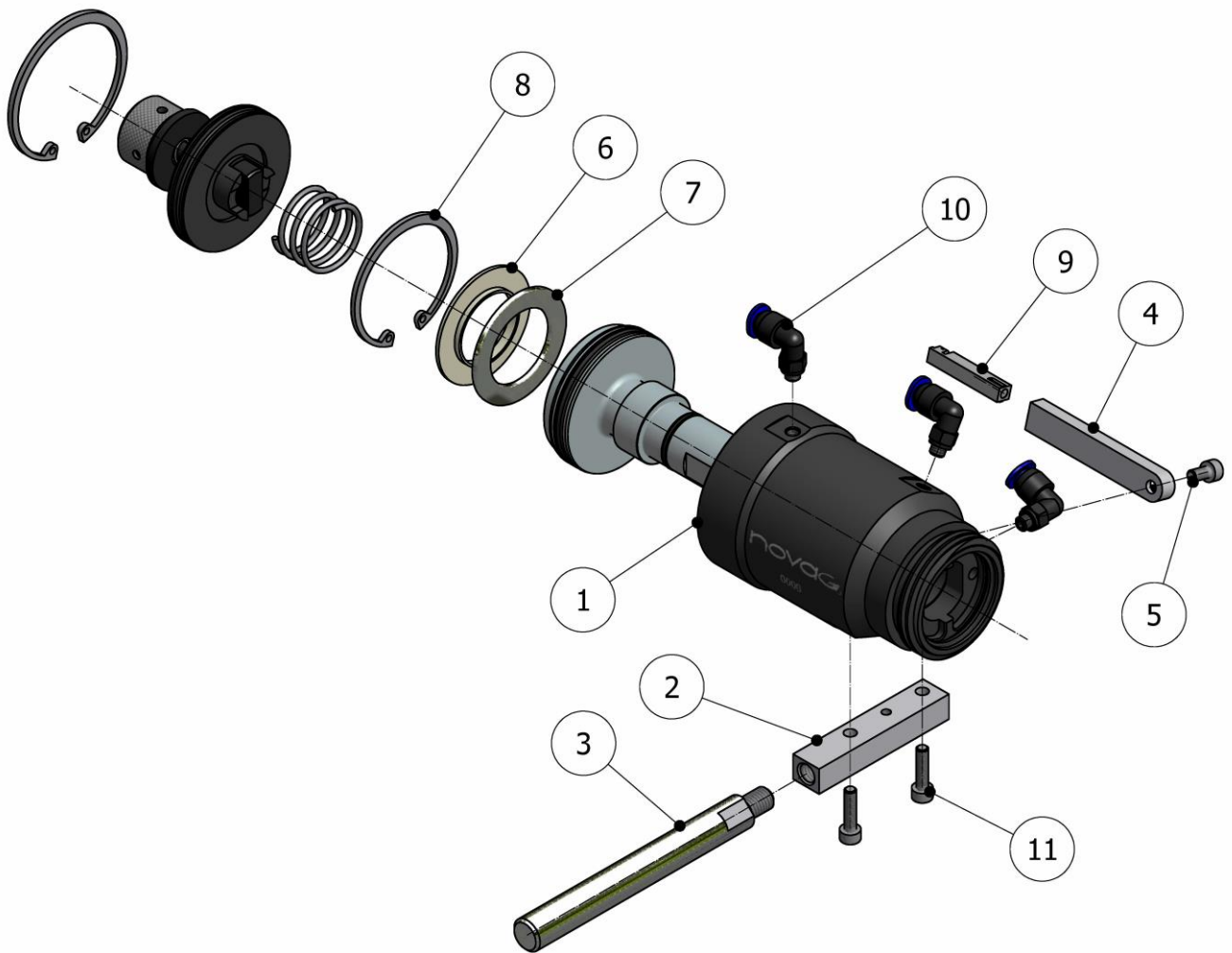

Figure 6. Assembly for Auto Version (OPTIONAL)

**Table 6. Assembly for Auto Version Component List (OPTIONAL)**

Pos.	Description	Reference	Qty.
1	Auto Version Gun Sleeve	NGU-07002-ATM	1
2	Auto Gun Support	GU-02055	1
3	Connecting Rod	GU-02056	1
4	Detector Support	GU-02051	1
5	Allen Bolt	TN-00002	1
6	Magnet Cover	GU-07025	1
7	Magnet	GU-07024	1
8	Seeger Ring	TN-00208	1
9	Magnetic detector with 2.5m cable + 1 .3-pole connec.	EL-00136-04	1
10	90° Elbow Connector	RA-00088	3
11	Allen Bolt	TN-00001	2



HEAD ASSEMBLY

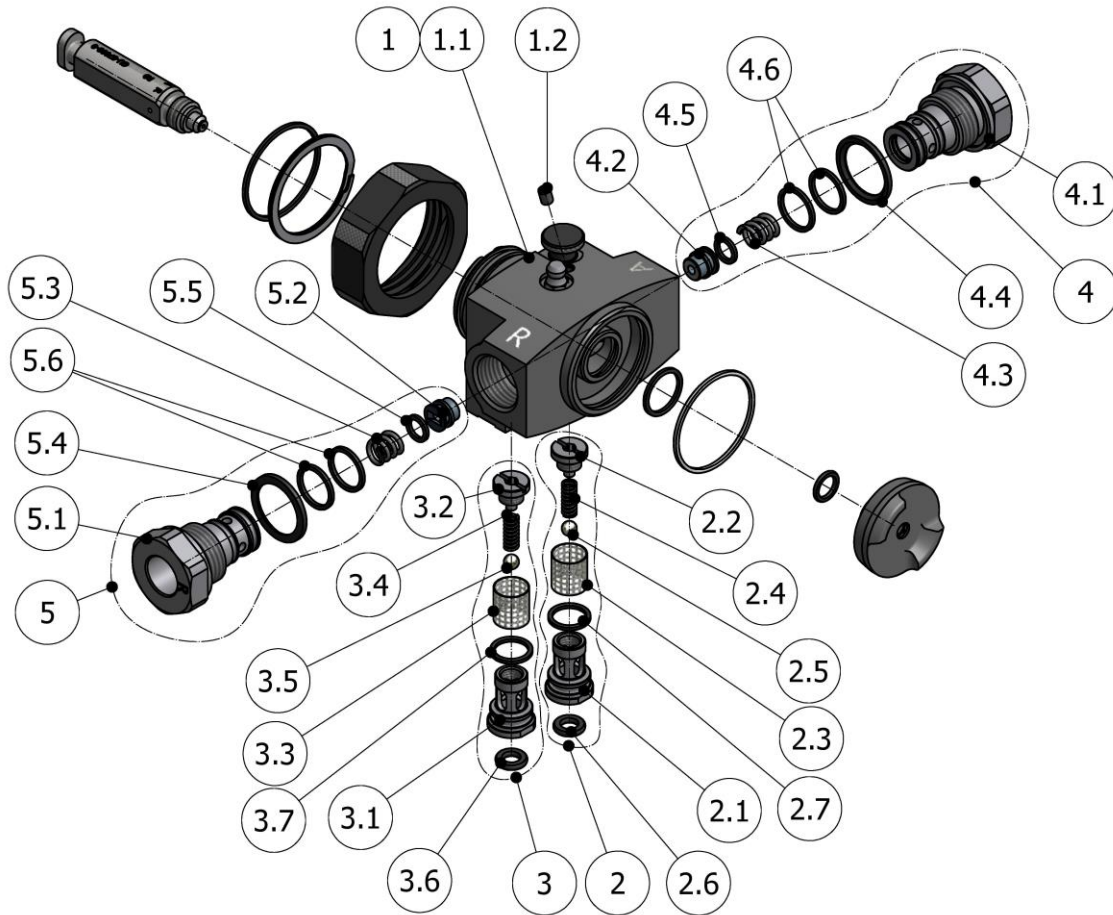

Figure 7. Head Assembly



Table 7. Head Assembly Component List

Pos.	Description	Reference	Qty.
1	Head with Stoppers	GU-07001	1
1.1	<i>Machined Head</i>	<i>GU-07001-01</i>	1 (*)
1.2	<i>Stopper</i>	<i>TN-00251</i>	3 (*)
2	Non return unit "A" ISO	GU-07003	1
2.1	<i>Non return unit body "A" ISO</i>	<i>GU-07005</i>	1 (*)
2.2	<i>Non-Return Cartridge Stopper</i>	<i>GU-07022</i>	1 (*)
2.3	<i>Filter 40 (standard), 60 and 80 Mesh (optional)</i>	<i>GU-02063-40 /60/80</i>	1 (*)
2.4	<i>Non-Return Spring</i>	<i>SP-00027</i>	1 (*)
2.5	<i>Non-Return Ball</i>	<i>TN-00228</i>	1 (*)
2.6	<i>O-ring</i>	<i>OR-00120</i>	1 (*)
2.7	<i>O-ring</i>	<i>OR-00119</i>	1 (*)
3	Non-Return Unit "R" POL	GU-07004	1
3.1	<i>Non-Return Unit Body "R" POL</i>	<i>GU-07006</i>	1 (*)
3.2	<i>Non-Return Cartridge Stopper</i>	<i>GU-07022</i>	1 (*)
3.3	<i>Filter 40 (standard), 60 and 80 Mesh (optional)</i>	<i>GU-02063-40 /60/80</i>	1 (*)
3.4	<i>Non-Return Spring</i>	<i>SP-00027</i>	1 (*)
3.5	<i>Non-Return Ball</i>	<i>TN-00228</i>	1 (*)
3.6	<i>O-ring</i>	<i>OR-00120</i>	1 (*)
3.7	<i>O-ring</i>	<i>OR-00119</i>	1 (*)
4	Friction Bushing Cartridge Unit "A" ISO	GU-07016	1
4.1	<i>Friction Bushing Holder "A" ISO</i>	<i>GU-07017</i>	1 (*)
4.2	<i>Metal Seal Bushing</i>	<i>GU-02049-02</i>	1 (*)
4.3	<i>Spring</i>	<i>SP-00005</i>	1 (*)
4.4	<i>Seal</i>	<i>OR-00121</i>	1 (*)
4.5	<i>O-ring</i>	<i>OR-00024</i>	1 (*)
4.6	<i>O-ring</i>	<i>OR-00074</i>	2 (*)



Pos.	Description	Reference	Qty.
5	Friction Bushing Cartridge Unit "R" POL	GU-07018	1
5.1	<i>Friction Bushing Holder "R" POL</i>	<i>GU-07019</i>	<i>1 (*)</i>
5.2	<i>Metal Seal Bushing</i>	<i>GU-02049-02</i>	<i>1 (*)</i>
5.3	<i>Spring</i>	<i>SP-00005</i>	<i>1 (*)</i>
5.4	<i>Seal</i>	<i>OR-00121</i>	<i>1 (*)</i>
5.5	<i>O-ring</i>	<i>OR-00024</i>	<i>1 (*)</i>
5.6	<i>O-ring</i>	<i>OR-00074</i>	<i>2 (*)</i>

N.B.:

The shaded positions correspond to the subunit codes.

The positions in italics form part of the respective subunits

() Individual quantities for each fitted subunit.*



PROJECTION TYPES AND SIZES

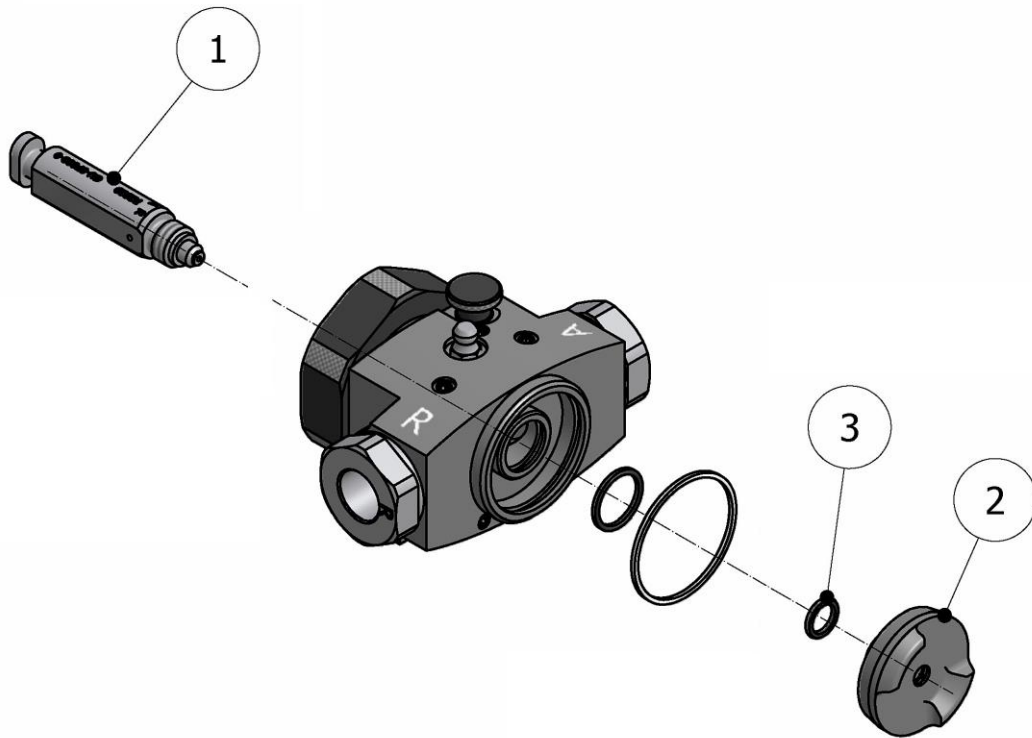

Figure 8. Projection Types and Sizes



Table 8. Projection Types Component List

Pos.	Description	Reference	Qty.
1	"Round" Mix Chamber Unit	See Table 9	1
2	"Round" Diffuser	GU-07011	1
3	O-ring	OR-00057	1

N.B.:

Pos. 2 include 1x Pos. 3 and 1x Cleaning Drill HT-00027

Pos. 4, 5, 6 and 7 are not available.

Table 9. List of Components depending on Round Chamber Production

Production (Kg/min.)	"Round" Mix Chamber Unit	Cleaning Drill 1 (*)	Cleaning Drill 2 (*)
0.56 – 3.8	GU-07008-000	HT-00074 + HT-00066	HT-00065
2 – 7.5	GU-07008-00	HT-00068 + HT-00066	HT-00062
2.2 - 9	GU-07008-0	HT-00063	HT-00062
2.4 – 11.2	GU-07008-1	HT-00065	HT-00066
3.5 – 17	GU-07008-2	HT-00062	HT-00029
5.4 – 20	GU-07008-3	HT-00066	HT-00075
6.1 – 25	GU-07008-4	HT-00029	HT-00070
10.8 – 27	GU-07008-5	HT-00075	HT-00100
	GU-07008-A000	HT-00015	HT-00024
2 – 7.5	GU-07008-A00	HT-00079	HT-00064

(*) Included in the Mix Chamber Unit.

ASSEMBLY POUR ADAPTER (OPTIONAL)

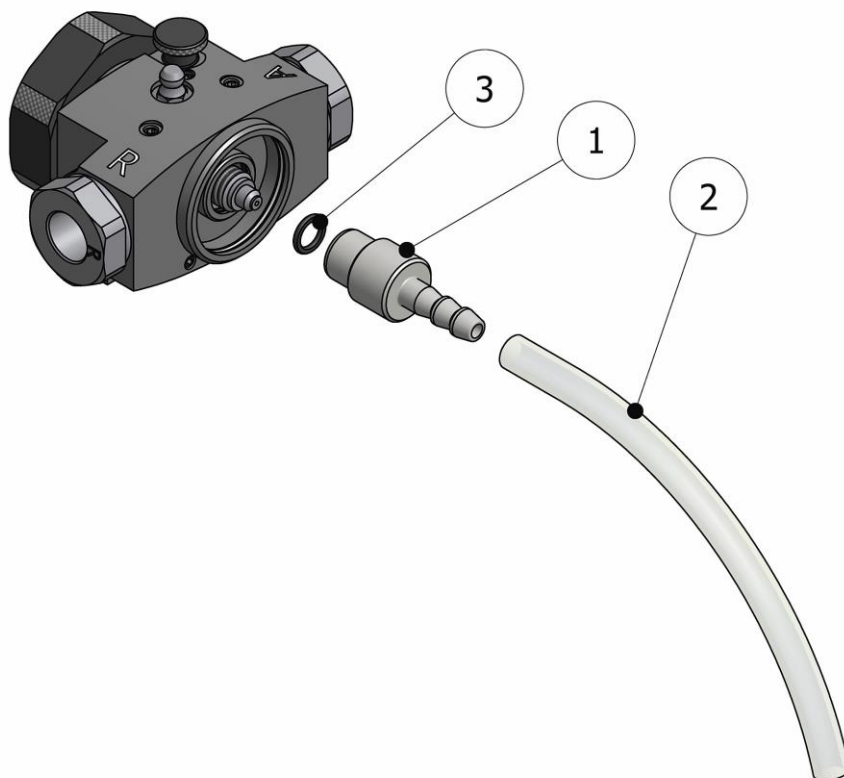

Figure 9. Assembly Pour Adapter (OPTIONAL)

Table 10. Pour Adapter, Parts List

item	Description	Reference	Qty.
1	Pour Adapter Body	GU-07026	1
2	Hose inner Ø 1/4"	NE-00043-SIZE	1
3	O-Ring	OR-00057	1

N.B.:

The "SIZE" nomenclature of item 2 determine the required hose length.

This adapter is valid for any size of round chambers.

When using this setup, remember to close the Air Regulator GU-07023 (see Table 2 on page 6.).



RECIRCULATION KIT (OPTIONAL)

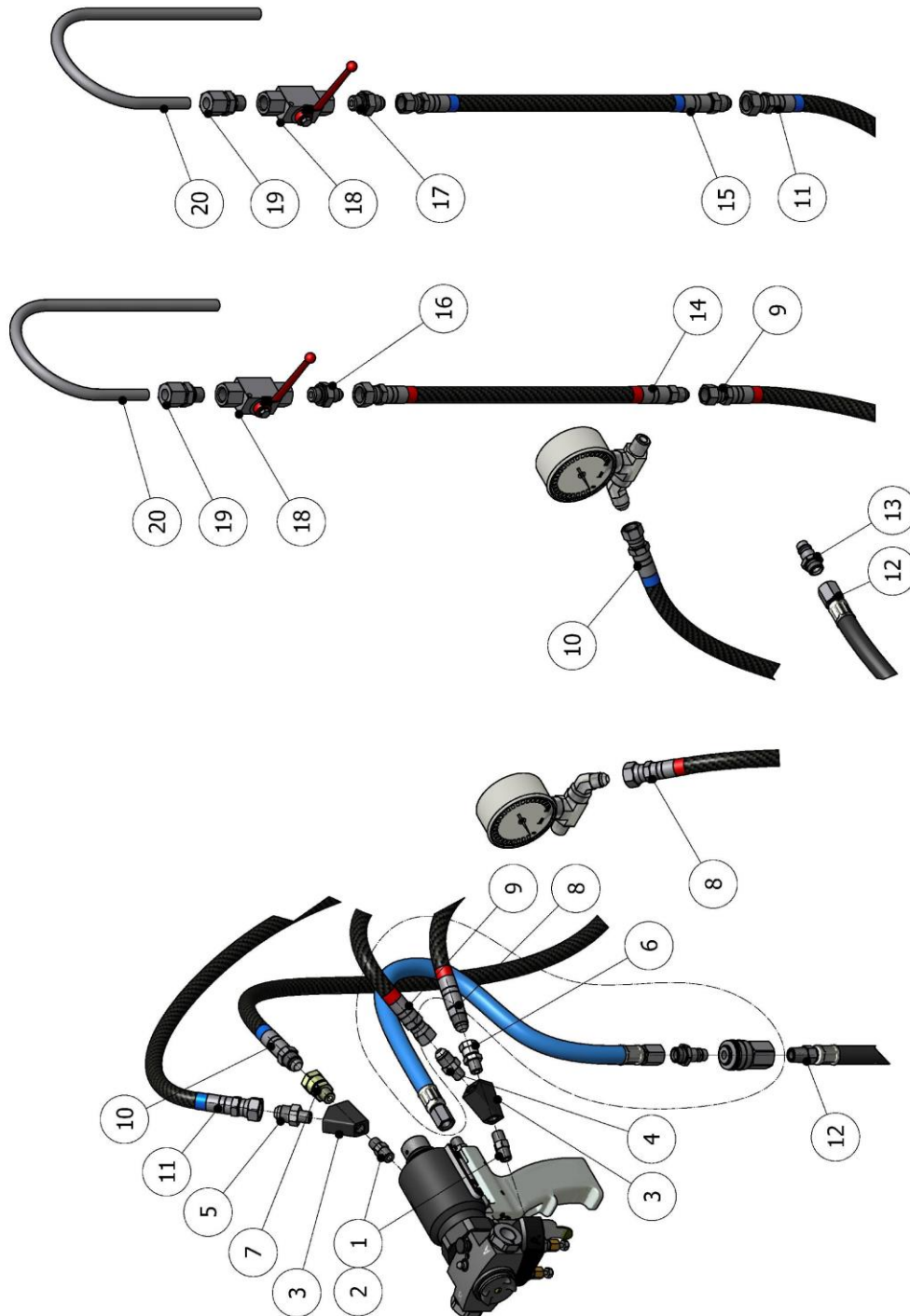

Figure 10. Recirculation Kit (OPTIONAL)
KT-00059-9



**Table 11. Recirculation Kit Component List (OPTIONAL)
KT-00059-9**

Pos.	Description	Reference	Qty.
1	Nipple	RA-00112	2
2	Elbow	RA-00205	2
3	Manifold	RA-00464	2
4	Nipple	RA-00238	1
5	Nipple	RA-00237	1
6	Swivel (*)	RA-00005	1
7	Swivel (*)	RA-00006	1
8	Flex 10000 mm Supply ISO	MA-00060-3	1
9	Flex 10000 mm Recirculation ISO	MA-00060-2	1
10	Flex 10000 mm Supply POL	MA-00059-3	1
11	Flex 10000 mm Recirculation POL	MA-00059-2	1
12	Air Hose	MA-00194	1
13	Air Coupler	RA-00110	1
14	Flex 1000 mm Recirculation Extended ISO	MA-00177	1
15	Flex 1000 mm Recirculation Extended POL	MA-00178	1
16	Nipple	RA-00144	1
17	Nipple	RA-00145	1
18	Ball Valve	RA-00217	2
19	Swivel	RA-00218	2
20	Tube	MQ-06016	2
	Hose Cover 10000 mm	MA-00123	
	Insulating Cover 10000 mm	MA-00099	
	Insulating Cover 8000 mm	MA-00099-1	

() Parts included in the standard assembly of gun.*

IMPORTANT NOTE:

Consult prices and delivery times with the Marketing Department for all OPTIONAL assemblies.



CLEANING KIT (OPTIONAL)

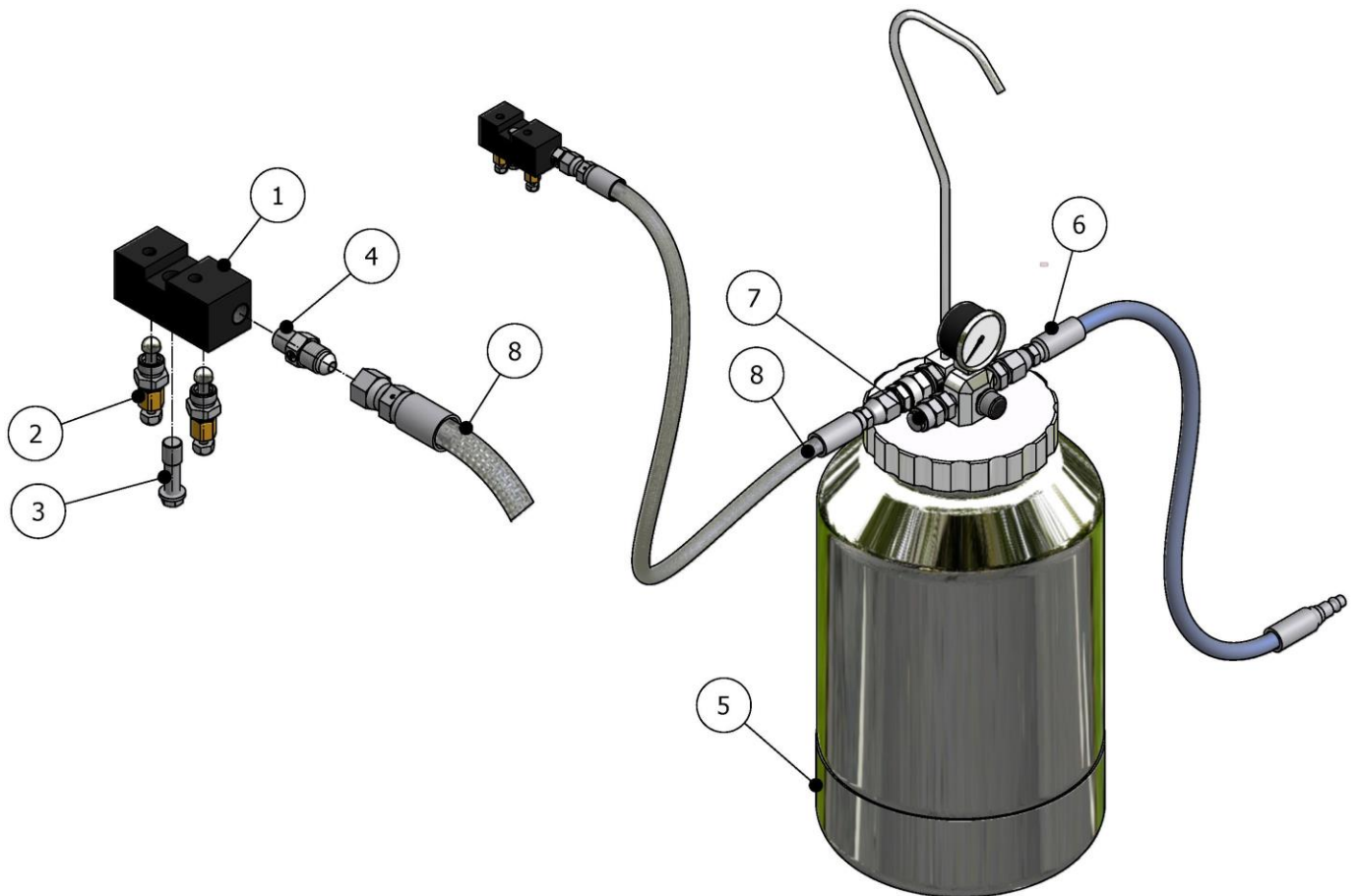

*Figure 11. Cleaning Kit (OPTIONAL)
KT-00072*



Table 12. Cleaning Kit Component List (OPTIONAL)
KT-00072

Pos.	Description	Reference	Qty.
1	Gun Adapter	GU-02138-00	1
2	Manual Valve Unit	GU-02020-00G	2
3	Input Block Screw	GU-04036	1
4	Pillar	RA-00108	1
5	Pressurised Tank 2 Lts. (Standard)	BI-00007-2	1
	Pressurised Tank 10 Lts. (Optional)	BI-00007-10	1
6	Air Hose 0.5 m	MA-00097	1
7	Stopper	RA-00328	1
8	Cleaning Hose 10 m	MA-00063	1

N.B.:

Delivery times for this assembly, consult the Marketing department.



CONTENT

Guarantee	2
Standard Final Assembly	3
Ball Valve Final Assembly (OPTIONAL)	5
Air Cylinder and Grip Assembly	7
Magnetic Micro Assembly (OPTIONAL)	10
Timer Assembly (OPTIONAL)	11
Assembly for Auto Version (OPTIONAL)	13
Head Assembly	15
Projection Types and Sizes	18
Assembly Pour Adapter (OPTIONAL)	20
Recirculation Kit (OPTIONAL)	21
Cleaning Kit (OPTIONAL)	23
Content	25
Illustrations List	25
List of Tables	26

ILLUSTRATIONS LIST

Figure 1. Standard Final Assembly, novaG-A Gun	3
Figure 2. Ball Valve Final Assembly (OPTIONAL)	5
Figure 3. Air Cylinder and Grip Assembly	7
Figure 4. Magnetic Micro Assembly (OPTIONAL)	10
Figure 5. Timer Assembly (OPTIONAL)	11
Figure 6. Assembly for Auto Version (OPTIONAL)	13
Figure 7. Head Assembly	15
Figure 8. Projection Types and Sizes	18
Figure 9. Assembly Pour Adapter (OPTIONAL)	20
Figure 10. Recirculation Kit (OPTIONAL)	21
Figure 11. Cleaning Kit (OPTIONAL)	23



LIST OF TABLES

Table 1. Standard Final Assembly Component List	4
Table 2. Ball Valve Final Assembly Component List (OPTIONAL)	6
Table 3. Grip and Air Cylinder Component List	8
Table 4. Magnetic Micro Assembly Component List (OPTIONAL)	10
Table 5. Timer Assembly Component List (OPTIONAL)	12
Table 6. Assembly for Auto Version Component List (OPTIONAL)	14
Table 7. Head Assembly Component List	16
Table 8. Projection Types Component List	19
Table 9. List of Components depending on Round Chamber Production	19
Table 10. Pour Adapter, Parts List	20
Table 11. Recirculation Kit Component List (OPTIONAL)	22
Table 12. Cleaning Kit Component List (OPTIONAL)	24