

Service Manual

HT BLACK GUN

Issue 1.4 - 13/10/2025

Ref. NR-00046-ENG

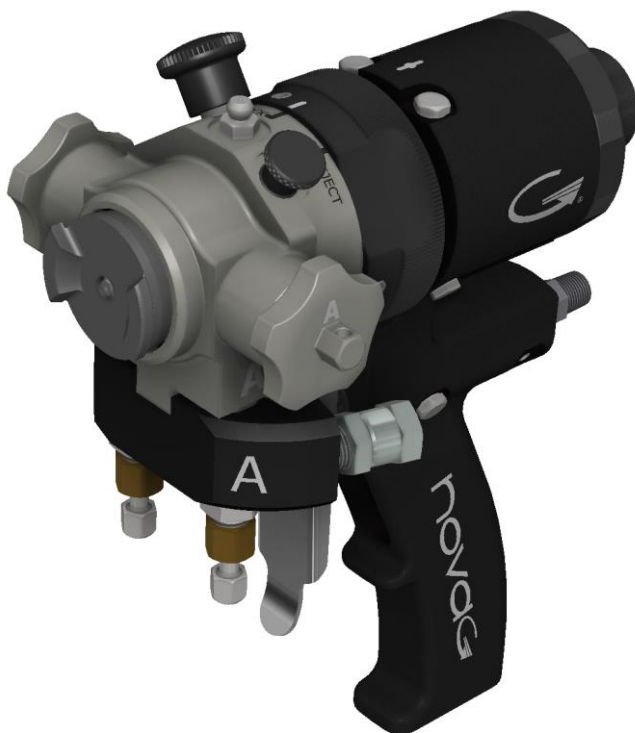

Before installing and operating the HT BLACK GUN, carefully read the technical and safety documentation in this manual. Special attention should be paid to the information in order to know and understand the handling and conditions of use of the Unit. All of the information is aimed at enhancing User Safety and avoiding possible faults due to incorrect use of the Unit.



WARRANTY

HI-TECH SPRAY EQUIPMENT, S. A. (hereinafter "HI-TECH") grants this Limited Guarantee to the original buyer (hereinafter the "Client") for the unit and the original accessories given with the unit (hereinafter the "Product") against any fault in the design, materials or manufacture of the Product at the time of the first purchase by the user and for a duration of two (2) years thereafter, except in the case of hoses and TSU's, which will have a warranty period of one (1) year. Additionally, for any other product manufactured by external suppliers, the warranty period will be as specified by the manufacturer.

If during the guarantee period and under normal conditions of use, the Product should fail to work correctly due to defects of design, material or manufacture, the authorised distributor of the country where the HI-TECH Product or technical assistance service has been purchased shall repair or replace the Product in accordance with what is established in the following

CONDITIONS

- a) The validity of this guarantee will be subject to the presentation of the original invoice issued by the HI-TECH authorised distributor for the sale of the Product along with the Product handed over for repair or replacement, which must show the date of purchase and the serial number. HI-TECH reserves the right to refuse to give the guarantee service when the indicated data fail to appear on the invoice or have been modified after the purchase of the Product.
- b) The repaired or replaced Product will continue to maintain the original guarantee for the time remaining until the end of the guarantee or for three (3) months from the repair date, if the remaining period of the original guarantee were shorter.
- c) This guarantee will not be applied to the faults in the Product caused by its faulty installation, the natural wear and tear of the components, any use other than that considered normal for this Product or which should fail to strictly comply with the instructions of use provided by HI-TECH; due to accident, carelessness, adjustments, alterations or modifications of the Product not authorised by HI-TECH or due to the use of accessories, heating devices, pumping equipment and/or dispensers that have not been approved or manufactured by HI-TECH.
- d) The guarantee applicable to the components and accessories forming part of the Product and which have not been made by HI-TECH will be limited to the guarantee offered by the original manufacturer thereof.

HI-TECH WILL NOT RECOGNISE ANY EXPRESS ORAL OR WRITTEN GUARANTEES OTHER THAN THIS PRINTED LIMITED GUARANTEE. ALL IMPLICIT GUARANTEES, INCLUDING, WITHOUT LIMIT, ADAPTATION FOR A SPECIFIC USE, ARE SUBJECT TO THE DURATION OF THIS WRITTEN GUARANTEE. HI-TECH DOES NOT ASSUME ANY KIND OF COMMITMENT OR RESPONSIBILITY FOR ALL POSSIBLE DAMAGE OR EXPENSE CAUSED BY FAULTS IN THE OUTPUT OF THE PRODUCT, ITS WORKING OR THE DISPENSING OF MATERIAL THROUGH THE PRODUCT, INCLUDING, WITHOUT LIMITATION, ALL EXPENSES CAUSED BY DAMAGE TO PEOPLE OR PROPERTY. EQUALLY, HI-TECH WILL IN NO CASE ACCEPT LIABILITY FOR THE LOSS OF SPECULATIVE PROFITS OR COMMERCIAL LOSSES. ALL REPAIRS OR REPLACEMENT OF FAULTY PRODUCTS WILL CONSTITUTE THE COMPREHENSIVE FULFILMENT OF HI-TECH'S OBLIGATIONS WITH RESPECT TO THE CLIENT. HI-TECH DOES NOT IN ANY WAY GUARANTEE THE SUITABILITY OR APTITUDE OF ITS PRODUCT FOR ANY PARTICULAR PURPOSE OR APPLICATION.

All of the information provided on components which have not been manufactured by HI-TECH and which is based on reports received from the original manufacturer, though considered precise and reliable, is provided without any guarantee or responsibility of any explicit or implicit kind.

All concession, sale or financial leasing of the Product by HI-TECH in no case explicitly or implicitly constitutes any authorisation, acceptance or concession for the use of any rights or patents, nor does it encourage, nurture or back their infringement.

The restrictions on the guarantee suppose no limitation on the legal rights of the consumer established in applicable national legislation, nor do they affect any rights derived from the bargain and sale agreement between the consumer and supplier.



All of the information provided in this manual has been included in the confidence that it is true, although it does not constitute any responsibility or implicit or explicit guarantee. HI-TECH reserves the right at any time without forewarning to make all necessary improvements and modifications to this manual in order to rectify any possible typographical errors, increase the information contained and enter the changes made to the characteristics and performances of the gun.

SAFETY AND HANDLING

The equipment described in this manual has been designed and manufactured in compliance with the following European Directives, following as application guide the harmonized standards detailed and in conformity with the relevant UK Statutory Instruments (and their amendments):

2006/42/EC Machinery Directive

2014/35/EU Low Voltage Directive

2014/30/EU EMC Directive

2011/65/EU RoHS Directive with amendment 2015/863

2012/19/EU Directive on waste electrical and electronic equipment

Standards used:

EN ISO 12100:2010

EN 60204-1:2018

EN IEC 61000-6-4:2019

EN IEC 61000-6-2:2019

EN IEC 63000:2018

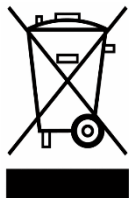

Electrical products cannot be thrown out with the rubbish. They must be taken to a dedicated collection point for an environmentally sound disposal in accordance with local regulations. You must contact your local collective or retailer for information about recycling. Before leaving WEEE at appropriate collection facilities, batteries must be removed and disposed of separately for proper recycling. The packaging materials are recyclable. Dispose of packaging materials in an environmentally sound manner and place them at the disposal of recycling sectors.

TRANSPORT AND STORAGE

Proper precautions must be taken so that the equipment can withstand the effects of transport and storage temperatures between -25°C and $+55^{\circ}\text{C}$ or up to $+70^{\circ}\text{C}$ for short periods that do not exceed 24 hours. Also, appropriate means to prevent damage from moisture, vibrations or shocks must be foreseen.



METHOD OF THREADED UNION OF THE HOSES

Follow the torques for threaded joints listed in **Table 1** according to thread sizes of hose fittings to ensure their proper assembly.

There is also an alternative procedure to obtain an equivalent torque without using special tools: joint both ends of the hoses to be connected, tighten a swivel nut by hand (without using spanner) until there is resistance on the nut. Fit two spanners (1) on the fixed ends of the hoses and turn the swivel nut with a third spanner (2) as many flats from wrench resistance (FFWR) as indicated in **Table 1**.

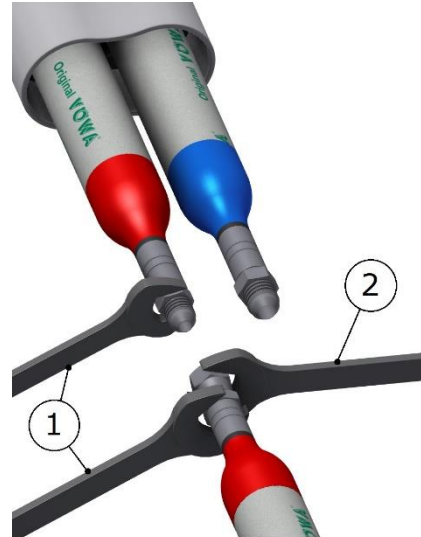

THREAD SIZE	TORQUE Nm	FFWR
1/2"-20	23	2 (or 120°)
9/16"-18	30	1-1/2 (or 90°)

NOTE: 1 FFWR corresponds to one complete shear of a flat marked with red between swivel and fitting or else 60°.

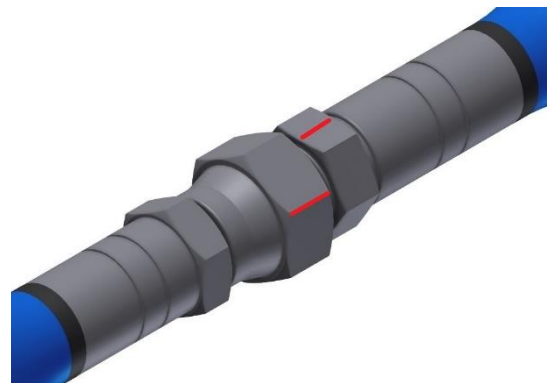



This chapter contains important information on safety, handling and use of your **HT Black Gun**.



Before installing and operating the gun, carefully read the technical and safety documentation in this manual. Special attention should be paid to the information for knowing and understanding the handling and conditions of use of the gun. All of the information is aimed at enhancing User Safety and avoiding possible faults due to incorrect use of the gun.

A **WARNING!** establishes information for alerting you on the situations which could cause serious injury if the instructions are not followed.

A **PRECAUTION!** establishes information which indicates how to avoid damage to the gun and how to avoid a situation which could cause minor injuries.

A **NOTE** is relevant information on the procedure being carried out.

Careful study of this manual will help you to become more acquainted with the gun and the procedures. Following the instructions and recommendations here will reduce the potential risk of accidents in installing, using or maintaining the gun, and will give you the problem-free operation for a longer time, greater output and the possibility of detecting and resolving problems quickly and simply.

Keep this Service Manual for future consultation of useful information at all times. If you lose the manual, ask for a new copy from your local **HI-TECH** distributor or make direct contact with **HI-TECH SPRAY EQUIPMENT, S. A.**

*****WARNING:** The gun's design and configuration do not allow it to be used in potentially explosive atmospheres or to exceed the pressure and temperature limits described in the technical specifications of this manual.***

Always use liquids and solvents that are compatible with the unit. In the event of doubt, consult the **HI-TECH** technical service.

When working with the gun, it is essential to dress suitably and use personal protection equipment, including the unlimited use of gloves, protective goggles, safety footwear and face masks. Use breathing equipment when working with the gun in enclosed or insufficiently ventilated atmospheres. The introduction and follow-up of safety measures must not be limited to those described in this manual. Before starting to use the gun, a rigorous analysis must be made of the risks derived from the products to be dispensed, the type of application and the working environment.



The gun forms part of the projection equipment, which is why all safety measures must be taken that are provided for the start-up use of the equipment, in addition to all specific measures for the use of the gun.



Carefully read the safety data sheet provided by your supplier to prevent any possible injury caused by incorrect handling of the raw materials and solvents used in the process.

Deal with the waste caused according to current regulations.



To prevent serious damage caused by the impact of fluids under pressure, never open a connection or do maintenance work on components subject to pressure until you are sure that all pressure has been eliminated.



Use suitable protection when operating, maintaining or simply being in the area where the equipment is working. This includes, but is not limited to, the use of protective goggles, gloves, shoes and safety clothes and breathing equipment.

The equipment includes components which reach high temperatures and may cause burns. The hot parts of the unit must not be handled or touched until they have completely cooled.



To prevent serious injury caused by crushing or amputations, do not work with the equipment if the moving part safety protections are not duly installed. Make sure that all safety protections are correctly fitted after carrying out repair or maintenance work on the equipment



CHARACTERISTICS

- * High-pressure internal mixture
- * Automatically cleaning by pressurised air
- * No solvents required
- * Mechanical spraying
- * Exterior greasing of the mix chamber

Approximate weight (without Coupling Block): 1.25 kg
Dimensions: H 21.4 cm / A 10.8 cm / L 16.5 cm

SPECIFICATIONS

Maximum working pressure:	240 bar (24 MPa)
Required air pressure:	6-8 bar (0.6-0.8 MPa)
Maximum production ratio 1:1:	18 kg/min
Minimum production ratio 1:1:	1.5 kg/min
Opening force @ 6 bar:	96 kg
Closing force @ 6 bar:	109 kg
Approximate air consumption @ 6 bar (50 cycles/min):	307 l/min

Values obtained according to UNE-EN ISO 3746:1995 standard

A-weighted sound pressure level:	77.4 dB
A-weighted sound power level:	88.1 dB



GENERAL DESCRIPTION

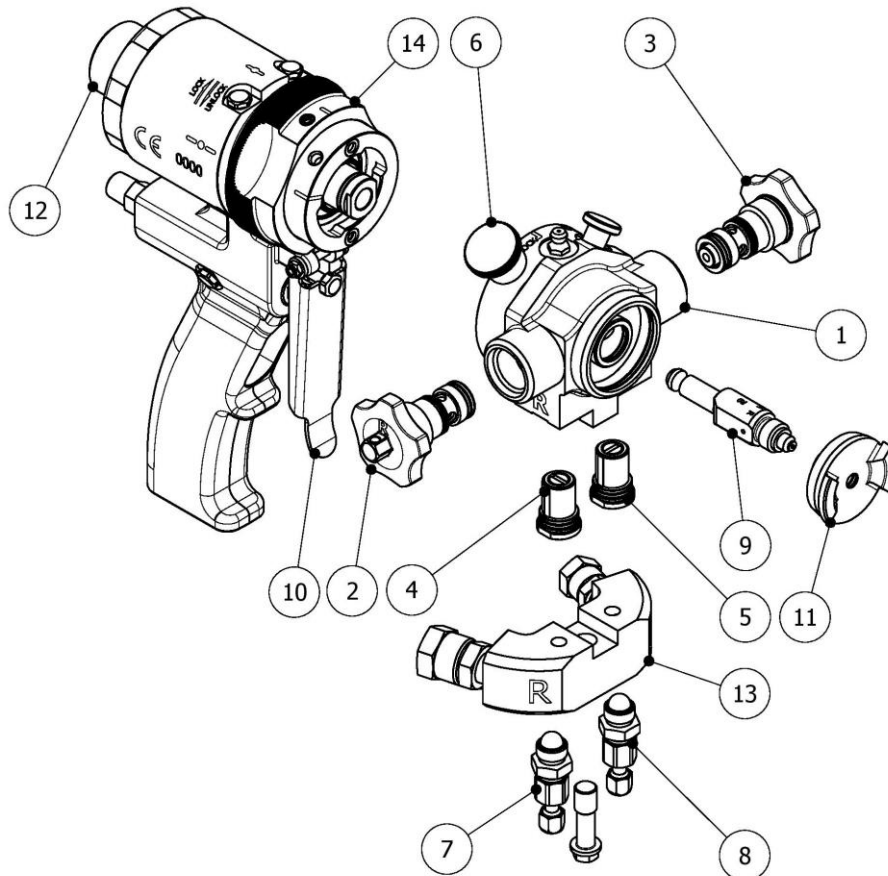

For a better understanding of the elements that make up the **HT BLACK GUN**, the main components are shown, along with their descriptions. For more specific identification, see the Parts Manual ref. **NR-00045-ENG**.

1. Mixing Head Assembly.
2. Polyol Side Cartridge Assembly.
3. Isocyanate Side Cartridge Assembly.
4. Polyol Check Valve Cartridge Assembly.
5. Isocyanate Check Valve Cartridge Assembly.
6. Mixing Head Lock Knob.
7. Polyol Manual Valve.
8. Isocyanate Manual Valve.
9. Mixing Chamber
10. Trigger.
11. Diffuser.
12. Locking Device.
13. Coupling Block.
14. Chamber Ejection Ring



ATTACHING THE MIXING HEAD

The following section provides the key points for proper attachment and removal.

The mixing head has a lock and unlock knob to secure it to the gun body. A reference mark alignment when installing the mixing head on the gun body.

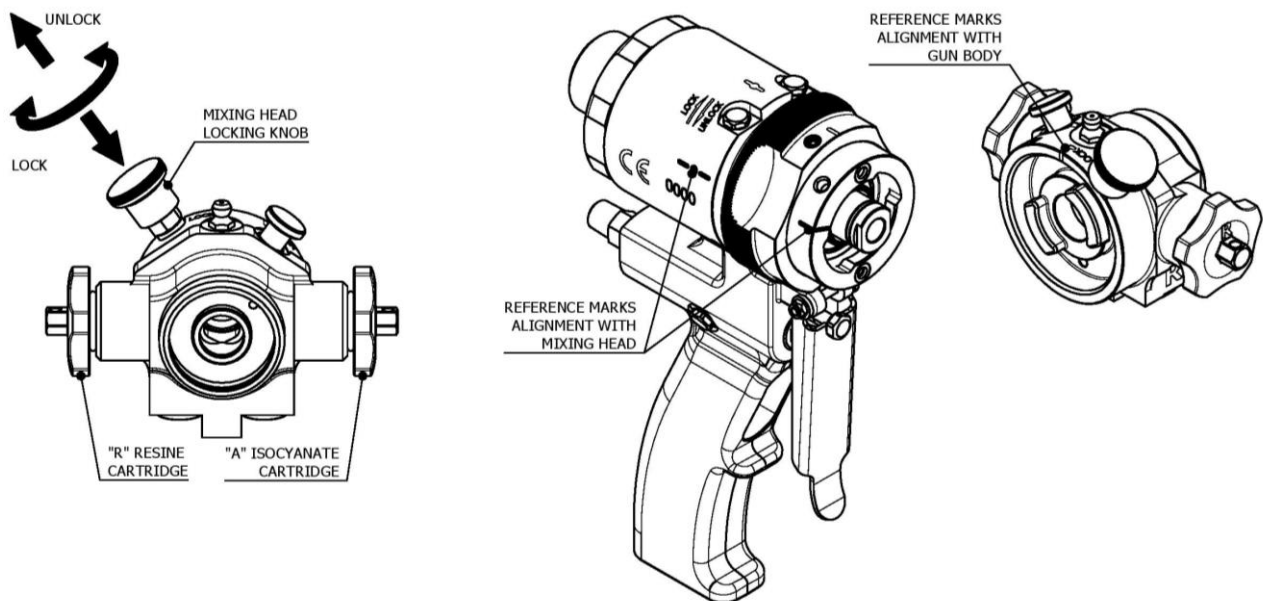

NOTE: The mixing head can be installed on the gun body, with or without the chamber (without the diffuser) mounted on the shaft (valid only for the round version). To do this, retract the side seals bushings located on the side cartridges and loosen them by 1.5 turns (maximum 2 turns).

It is advisable to screw and unscrew the cartridges by hand; the wrench that is provided should be used to loosen the cartridges only if necessary.

The correct working position of the side cartridges is with the inside surface of the cartridges in contact with the base of the mixing head threads. If they are not in contact, remove the cartridges and carefully clean the housing and cartridge.

The assembly, disassembly and inversion of the mixing head must be done without the coupling block mounted on the mixing head.



The assembly procedure is as follows:

1. Pull out the mixing head lock knob and turn it so that it stays in place.
2. Line up the upper reference mark of the mixing head with the attachment/removal reference marks on gun body (on the front and on the side of the cylinder).
3. Push the mixing head all the way in and release the lock knob by turning it slightly in either direction.
4. Turn the mixing head clockwise (normal assembly) or counter-clockwise (inverted assembly) until the side cartridges are completely horizontal. At this point, you should hear a **CLICK** and the knob should retract, locking the mixing head on the gun body.

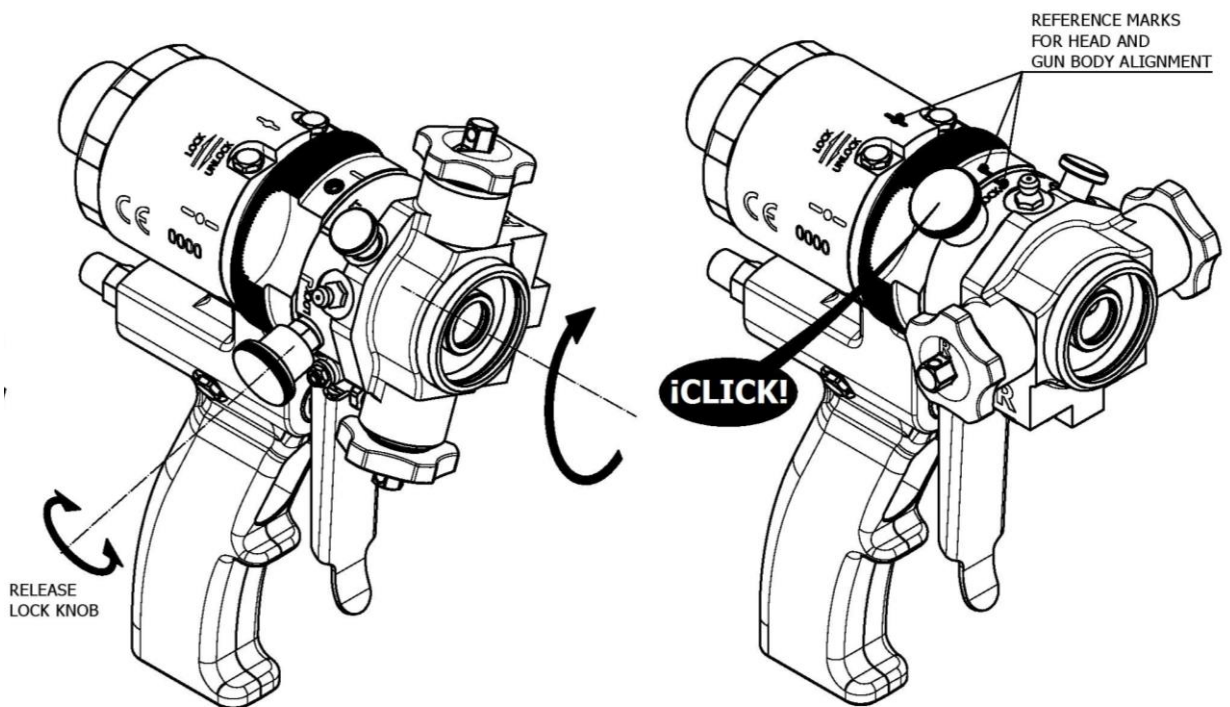
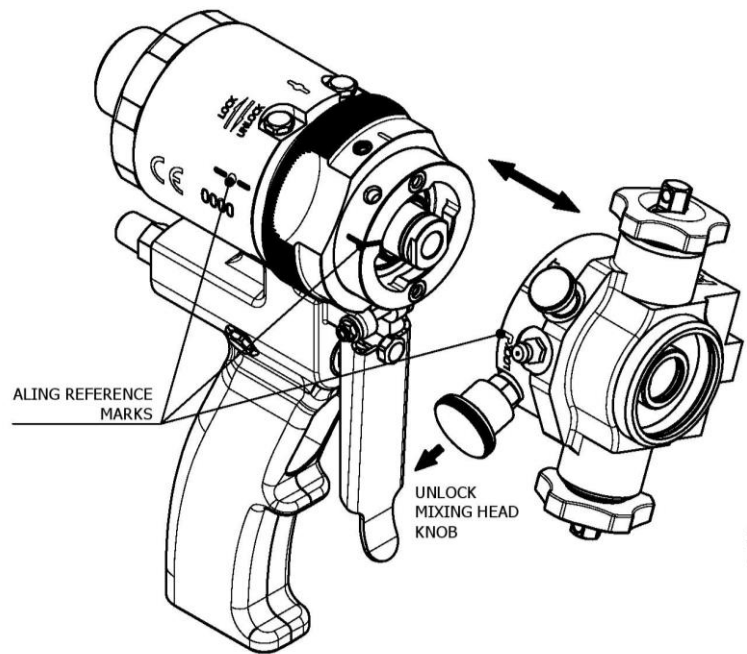



REMOVING THE MIXING HEAD

1. Pull out the mixing head lock knob and turn it so that it stays in place.
2. Then turn the head until the reference marks for the release position are aligned.
3. Pull the mixing head to separate it from the gun body.

To turn the mixing head when it is mounted on the gun body;

1. Pull out the mixing lock knob and turn it so that it stays in place.
2. Then rotate the mixing head 180° until the product intakes are facing up. At this point, you should hear a CLICK and the knob should retract, locking the mixing head on the gun body.

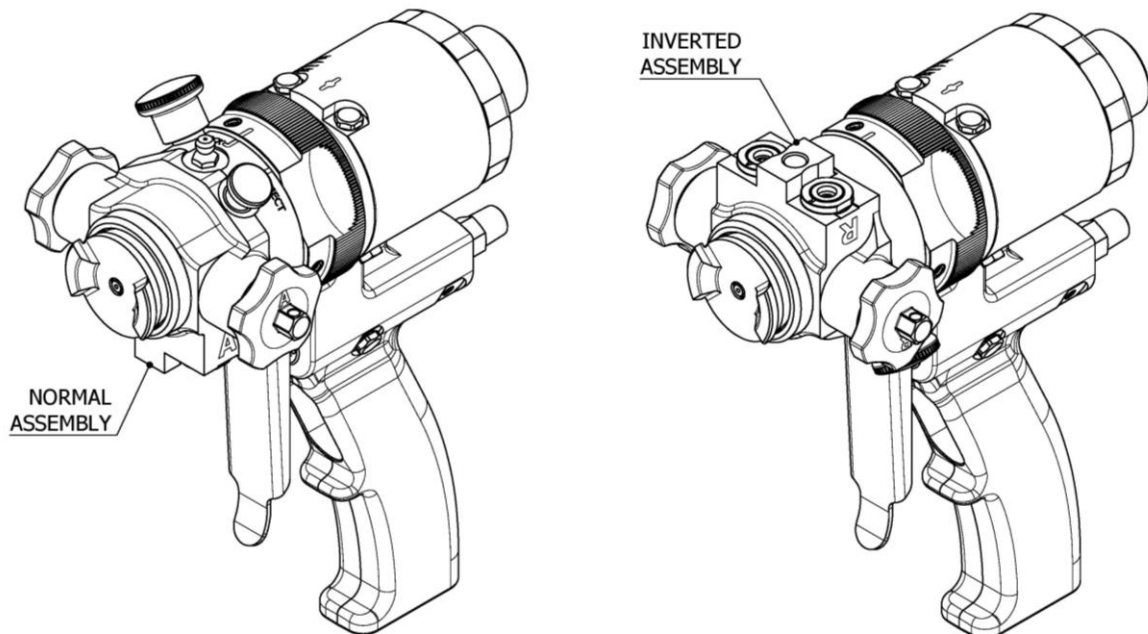

NOTE: To turn the mixing head, the coupling block with the product hoses must be uncoupled. The mixing head can be rotated with or without the chamber and diffuser attached.

CAUTION! DO NOT interchange the isocyanate parts A with the polyol parts R; this could cause serious damage to the gun.

Note that in the inverted position, the isocyanate side A will be on the right, with the gun in its working position.



INSERTING AND EJECTING THE MIXING CHAMBER

This spray gun has a chamber locking mechanism that allows it to be attached and removed without having to disassemble other additional parts. There is a locking Ejection Ring that acts on the chamber lock to automatically eject the chamber. The chamber can be removed with or without the diffuser attached.

The chamber Eject Ring has markings that indicate whether the chamber is in working mode (locked or LOCK) or maintenance mode (unlocked or EJECT).

The chamber can only be ejected from the mixing head in maintenance (EJECT) mode.

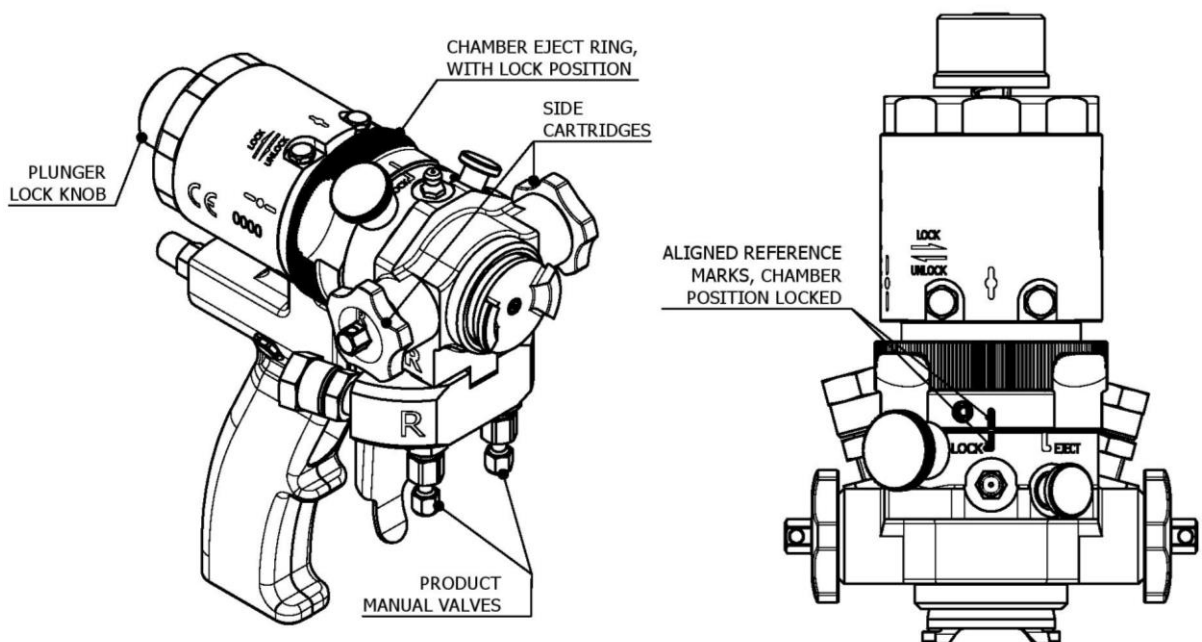

To replace the chamber, proceed as follows:

1. Activate the plunger lock knob.
2. Close the manual valves for each product in the coupling block.
3. Loosen the side cartridges 1.5 turns (maximum 2 turns).

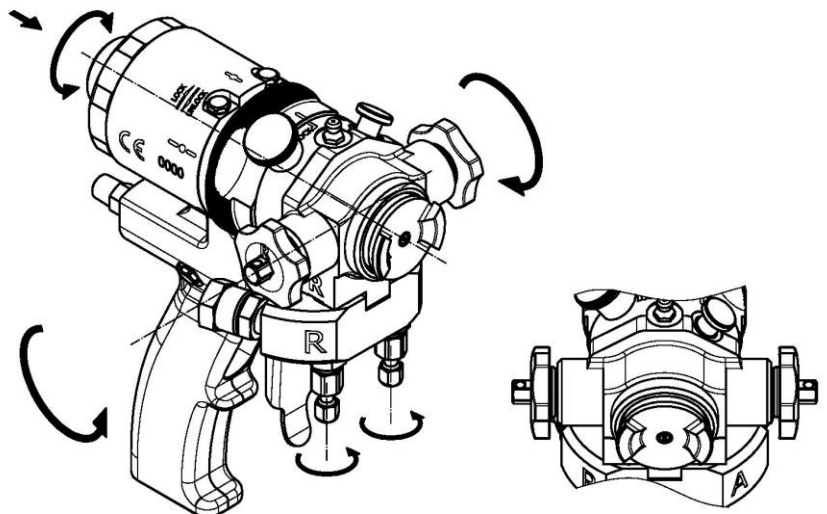



Step 1
Ejection ring in working LOCK position.
Loosen side cartridges 1.5 or 2 turns.

Step 2
Retract the ejection ring.

Step 3
Turn the ejection ring to the maintenance EJECT position.

Step 4
Pull the ejection ring back and the chamber will be released.

Working position LOCK

Maintenance position EJECT



To insert the chamber, follow the steps of the procedure in reverse.

CAUTION! *The mixing chambers are identified by the letters A and R on each corresponding side. Remember to mount the chamber on the gun in the proper orientation, with the mixing head in the normal or in the inverted position.*

WARNING! *Before spraying, make sure that the chamber is properly inserted, by pulling the trigger several times with the air connected and the product manual valves closed, pointing the unit at a safe area away from people or hazardous objects.*

CAUTION! *Do not leave the mixing head without a chamber. When you extract one, insert another one immediately. To perform maintenance on the mixing head, remove the chamber and side cartridges to clean the entire assembly (mixing head, chamber and side cartridges).*

CAUTION! *Do not grease the chamber shaft because grease build-up in this area could cause the chamber's latching system to malfunction. Instead, use lubricating oil to coat the chamber shaft.*



INSTALLATION AND START-UP

WARNING! When working with or maintaining the gun, you should wear appropriate protection in accordance with the recommendations and specifications provided by the product suppliers.

HI-TECH provides a series of tools and accessories which are necessary for assembling the gun. The unit is made up of the following elements:

49gr. Tube of grease	BI-00009	1x
5/16" (8mm) Tube spanner	HT-00054	1x
Bits for cleaning	HT-00060	1x
Air hose supply	MA-00027	1x
Quick connect	RA-00109	1x
Drill Bits	According to Chamber Model (see NR-00045)	
Service Manual	NR-00046	1x
Parts Identification Manual	NR-00045	1x

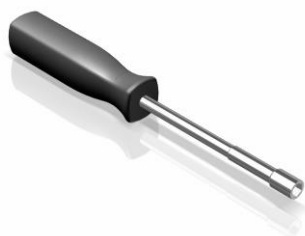

NOTE: To facilitate maintenance operations, the HT-00054 hand wrench is used for most of the gun's elements (handle and mixing head caps, trigger shaft retaining nut, intake block screw, manual product valves and other anchor screws for the different elements that make up the gun).



HT BLACK GUN

Service Manual

1. Close the manual valves completely by turning them clockwise. The manual valves control the intake flow of each product into the chamber and are located in the Coupling Block.
2. Connect the air supply hose to the connector on the rear of the gun.
3. Connect the isocyanate hose (red terminal) to the isocyanate intake connector (letter A) located on the Coupling Block.
4. Connect the Polyol hose (blue terminal) to the Polyol intake connector (letter R) located on the Coupling Block.

NOTE: The product hoses have been differentiated with the colors red and blue to allow quick identification. Red corresponds to the Isocyanate hose and Blue to the Polyol hose. To avoid connection errors, the coupling connectors of the Isocyanate and Polyol hoses are different sizes, which makes it impossible to mix up the connections.

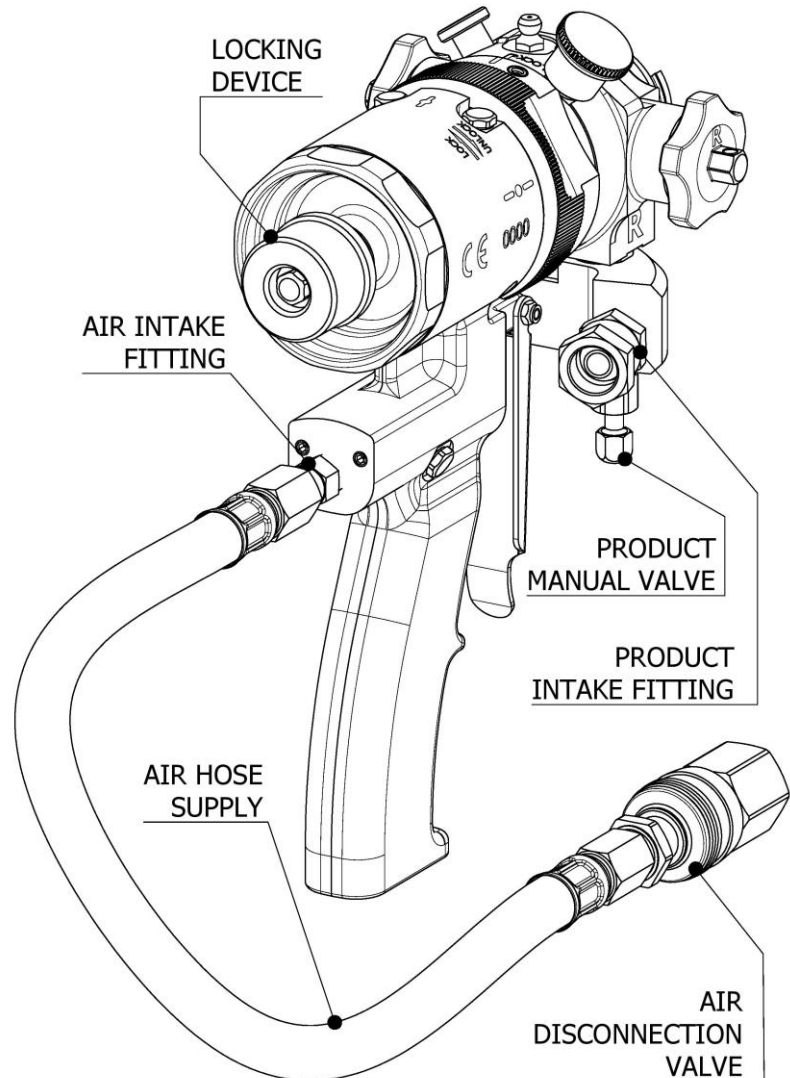

5. Connect the air valve.
6. Pressurize the unit and check for leaks.



WARNING! Ensure that the chamber is correctly inserted and locked in its mechanism and that the ejection ring is in the Operating Position (LOCK).



When checking that the chamber is secure, be careful to aim the gun towards a place where no damage will be caused if the chamber is not properly locked.

7. Pull the trigger several times to verify the correct movement of the mixing chamber.
8. Ensure that the pressure in the machine and the temperature of the heaters and hoses is correct (see the Service Manual for the Machine).

WARNING! Before opening the manual product valves, make sure that the mixing head is correctly mounted and locked in its working position, and that the mixing chamber is properly locked.

9. Open the manual valves of each product completely by turning them counter-clockwise.
10. Press the locking device and rotate it counterclockwise to place it in the spray mode or position.
11. Perform a spray test inside a container

WARNING! Before carrying out any maintenance, repair or cleaning work, press the locking device and turn it clockwise to the locked mode or position, always remove the coupling block from the gun, completely close the manual product intake valves and disconnect the air supply to avoid possible accidents.



SHUTDOWN PROCEDURES

1. Perform the Unit Shutdown Method by following the procedure in the machine's Service Manual.
2. Completely close the manual valves for each product by turning them clockwise.
3. To release the pressure in the gun, press the trigger and spray with the gun until the spray fan starts to decrease.
4. Press the plunger locking device and turn it clockwise to the locked position or mode.
5. Remove the coupling block from the gun. Clean the contact surfaces and seals of the check valves cartridges with a cloth moistened with solvent.
6. Remove the check valve unit with bottom filter and the contact bushing unit on the polyol side located on the mixing block or mixing head. Clean the unit with gun cleaning solvent.
7. Remove the check valve unit with bottom filter and the contact bushing unit on the Isocyanate side located on the mixing block or mixing head. Clean the unit with gun cleaning solvent.

NOTE: To remove the check valves filter cartridges, use a flat screwdriver and pry the assemblies out. Be careful not to damage the O-rings. If for some reason the cartridges cannot be removed using this procedure, as an alternative, you can use a threaded rod or M4 screw as an extractor.

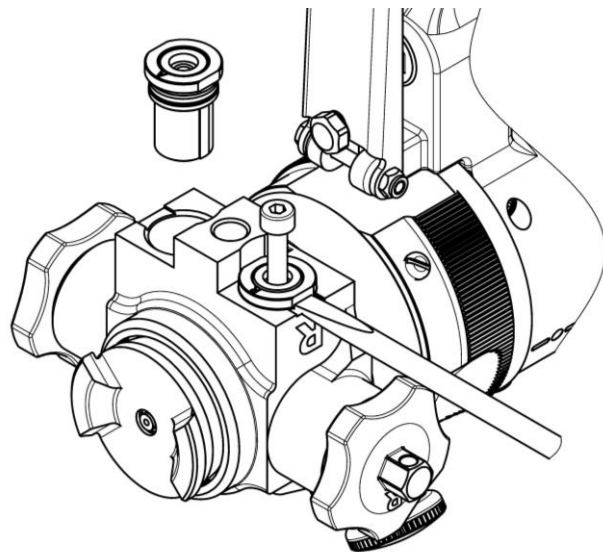

8. Remove the filters. Carefully clean them with gun cleaning solvent, making sure that the mesh is completely free of product residue.

CAUTION! To avoid spilling product that has accumulated in the side cartridges and the check valves cartridges on the floor, always remove the coupling block and cartridges over a waste container.

9. Remove the chamber and diffuser as described on page 12.
10. Remove the mixing head as shown on page 11. Clean the block with gun cleaning solvent.
11. Clean both contact surfaces of the mixing chamber.

CAUTION! Use wooden or plastic utensils or a brass brush for cleaning. Do not use metal utensils that could scratch the contact surfaces.

12. Assemble all components as shown on pages 9 and 12. Attach the coupling block on the gun.



13. The gun has a grease nipple located in the upper part of the head. Use it to grease the interior of the head and the chamber with the grease supplied in the kit along with the gun. This will prevent the cleaning air from the gun from drying out the ISOCYANATE product, thus preventing it from crystallizing and scratching the chamber and the bushing.

NOTE: *Lubricating the gun at the end of the day will decrease maintenance time because the chamber will not need to be disassembled each day to clean it.*

CAUTION! *To avoid possible contamination by product residues deposited on the gun components, do not mix up the Isocyanate and Polyol parts. The isocyanate side is identified on the gun with the letter A.*



If the product hoses are still pressurized, follow the Shutdown Method indicated in the Machine's Service Manual.

To relieve the pressure from the hoses with the gun disassembled, place the product intake coupling block in a suitable container, keep a safe distance away and open the manual valves very carefully and slowly. While under pressure, the product will come out of the top of the coupling block.



MAINTENANCE

To get the most out of your gun **HT Black Gun** certain maintenance operations need to be performed on a regular basis.



To prevent possible bodily harm caused by incorrect handling of the raw materials and solvents used in the process, please read the safety data sheet provided by your supplier carefully.

Handle the generated wastes according to the regulations in force.



To prevent serious damage caused by the impact of pressurized fluids, never open connections or perform maintenance on pressurized components until you are sure that all pressure has been eliminated.

Use appropriate protection when working, maintaining, or while present in the working area of the equipment. This includes, but is not limited to, the use of protective goggles, gloves, safety shoes and clothing, and breathing equipment.



The equipment includes components that reach high temperatures and can cause burns. Do not handle or touch hot parts of the equipment until they have cooled completely.



To prevent serious injury caused by crushing or amputation, do not work on the equipment without properly installed safety guards for moving parts. Make sure that all safety guards are properly installed when you finish repairing or maintaining the equipment



Gun block and mixing chamber unit

WARNING! Before carrying out maintenance work on the gun, make sure that the unit is completely stopped, that all buttons and the main switch are turned off and that the unit is disconnected from the main power supply. The gun is a component that works under pressure. You must not open any connections or carry out maintenance work on components under pressure until the pressure has been completely eliminated.

1. Remove the coupling block.
2. Clean the contact surfaces and seals of the check valves cartridges with a cloth moistened with solvent.

NOTE: If you need to replace any of the manual valves due to breakage or damage, make sure that they are completely open (that the ball is housed inside the body of the manual valve) before installing it on the coupling block. If not, the taps could be damaged during assembly.

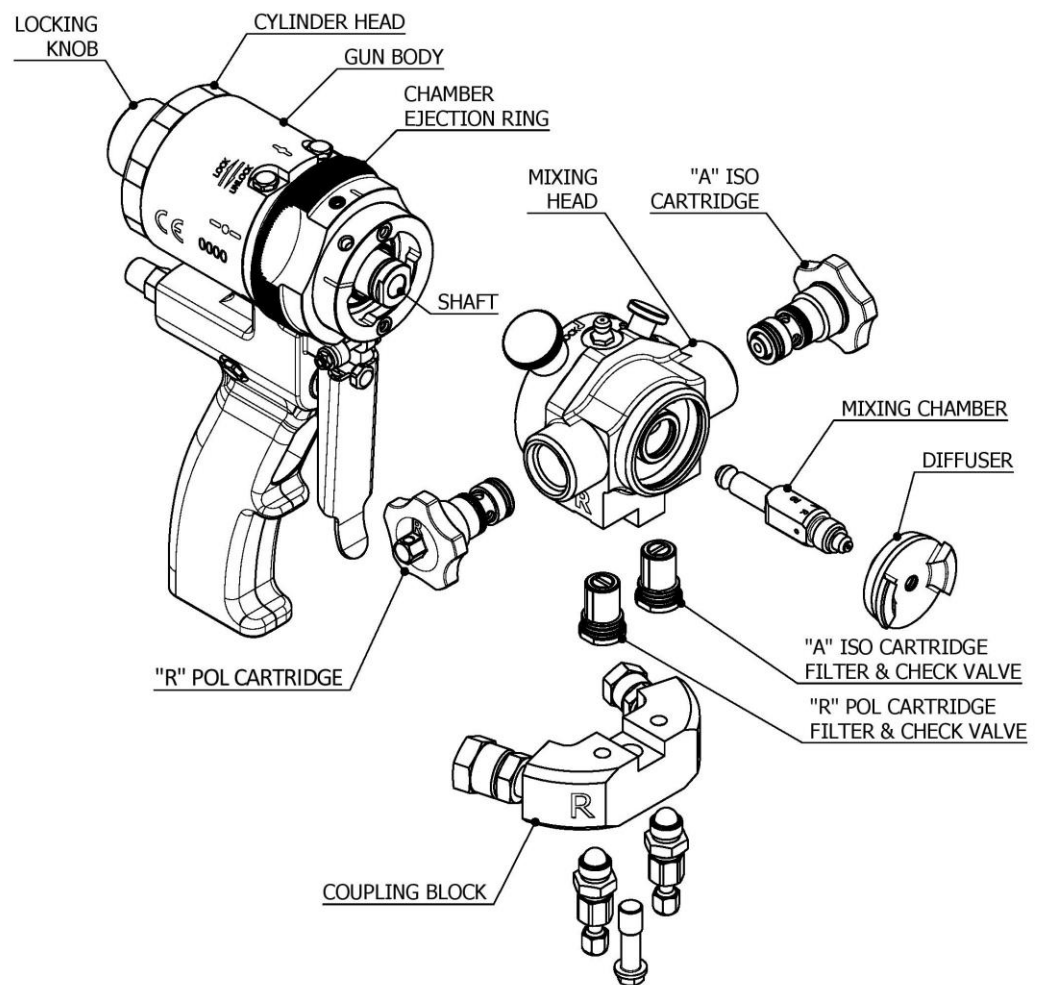

CAUTION! To avoid spilling product that has accumulated in the cartridges on the floor, always remove the coupling block and cartridges over a waste container.



3. Remove the lower check valve cartridges as shown on page 18 with the help of a screwdriver, threaded rod or screw. Be careful not to damage the seals.
4. Remove the mixing chamber from the mixing head (see page 12). Examine it and replace it if it has any flaws.
5. Remove the mixing head according to the instructions on page 11.
6. Unscrew and remove the isocyanate cartridge
7. Unscrew and remove the polyol cartridge.
8. Unscrew the diffuser from the chamber (if you have not done so before removing it) and examine the inside of the diffuser.

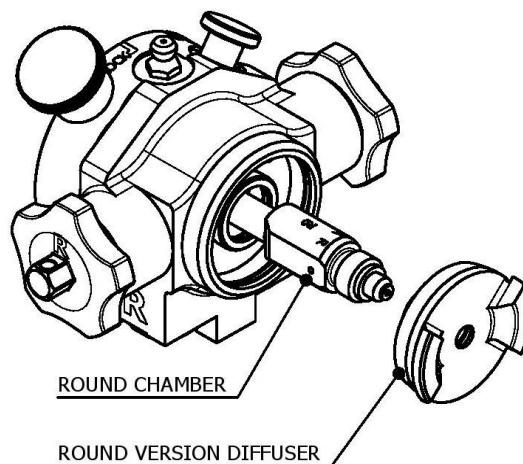

Round Spray Assembly

9. Make sure the air holes in the diffuser for projection are not obstructed. If they are blocked or dirty, clean them with suitable brushes of the right size.



Cleaning Air Projection Holes Round Version

Note: the diffuser cleaning bits are included with the diffuser in the spare parts as well as in the gun's tool kit.



10. To clean the product holes in the chamber, use the appropriate bits according to the size of the holes. To perform this operation, the chamber must be removed from the mixing head. The smaller chambers have a double diameter on the intake ports, so two different sized bits will be needed in each port.

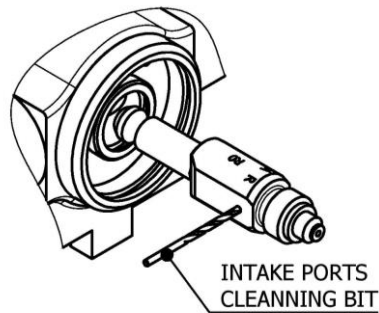

Cleaning Product Intake Holes Round Chamber

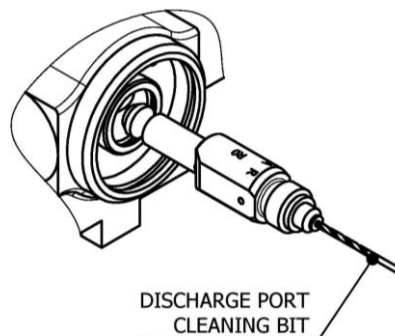

Cleaning Product Discharge Holes Round Chamber

Note: *the chamber cleaning bits are included with the spare parts as well as in the gun's tool kit.*

11. Place the block in a container with gun cleaning fluid.
12. To remove product residue, place the gun block assembly in a container with the gun cleaning liquid and scrub with a brass brush.

CAUTION! *Use wooden or plastic utensils or a brass brush for cleaning. Do not use metal utensils that could scratch the contact surfaces.*



To reassemble the gun, follow the procedure below:

13. Screw on the cartridge contact bushing holders by hand, paying attention to the location of each one (A ISO side and R POL side). After screwing them fully against the mixing head, loosen them by 1.5 turns (maximum 2 turns).
14. Attach the gun block assembly or mixing head as described on page 9 (in the normal or inverted position, as required).
15. Insert the mixing chamber into the mixing head, paying attention to its orientation (A ISO side, R POL side) according to the procedure described on page 10.
16. Screw the diffuser onto the chamber by hand.
17. Attach the filter cartridges and check valves on the mixing head, paying attention to the location of each one (A ISO side and R POL side). Be careful not to damage the cartridge seals when inserting them into the spray head (grease them to facilitate insertion).
18. Attach the coupling block.

Side cartridge unit

WARNING! Before carrying out maintenance work on the gun, make sure that the unit is completely stopped, that all buttons and the main switch are turned off and that the unit is disconnected from the main power supply. The gun is a component that works under pressure. You must not open any connections or carry out maintenance work on components under pressure until the pressure has been completely eliminated.

1. Perform the Unit Shutdown Method by following the procedure in the Machine's Service Manual.
2. Completely close the manual valves for each product by turning them clockwise.
3. To release the pressure in the gun, press the trigger and spray with the gun until the spray fan starts to decrease.
4. Disconnect the air supply from the gun.
5. Unscrew the isocyanate side cartridge by turning it counter-clockwise and remove it from its housing. Clean the housing with gun cleaning solvent and ensure that no loose particles are left inside.

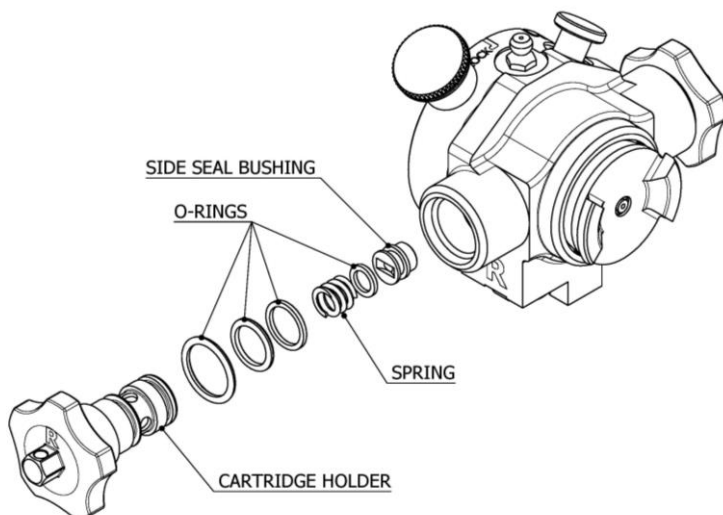



CAUTION! Use wooden or plastic utensils, or a brass brush, for cleaning. Do not use metal utensils that can scratch the surface.

Before cleaning the cartridge body, and the contact bushing with the cleaning agent, disassemble all of the O-rings in these components, so that they are not damaged by the cleaning fluid or the brass brush.

6. Check the o-rings of the cartridge and the side seal bushing. Replace them if they are worn or deteriorated.
7. Check the metal side seal bushing for wear by checking the total length of the bushing. Replace it if the length is less than 7 mm.
8. Grease all of the components and reassemble them in the cartridge.

CAUTION!: The first two o-rings of the three that each cartridge carries, are very similar dimensionally. To avoid confusion in assembly, the central o-ring OR-0018 has been differentiated with a different color (brown).

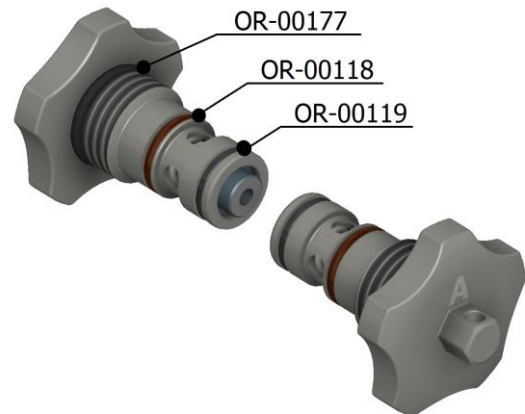

9. Screw the isocyanate cartridge unit into its housing until it stops at the base of the thread in the mixing head. Make sure it is correctly assembled to avoid product leaks. To do this, the largest seal of the cartridge should not be visible and the support face of the cartridge must be in contact with the seat base of the mixing head.
10. Do the same with the polyol cartridge (points 5-9).
11. Carry out the spray procedure indicated in the start-up section.
12. Start the gun.

CAUTION! Use wooden or plastic utensils or a brass brush for cleaning. Do not use metal utensils that could scratch the contact surfaces.

Filter and Check Valve Cartridge Unit

WARNING! Before carrying out maintenance work on the gun, make sure that the unit is completely stopped, that all buttons and the main switch are turned off and that the unit is disconnected from the main power supply. The gun is a component that works under pressure. You must not open any connections or carry out maintenance work on components under pressure until the pressure has been completely eliminated.

1. Perform the Unit Shutdown Method by following the procedure in the Machine's Service Manual.
2. Completely close the manual valves for each product by turning them clockwise.
3. To release the pressure in the gun, press the trigger and spray with the gun until the spray fan starts to decrease.
4. Disconnect the air supply from the gun.



HT BLACK GUN

Service Manual

5. Remove the lower check valve cartridges as shown on page 18, with the help of a screwdriver, threaded rod or screw.
6. Separate the filter and clean it with gun cleaning solvent. Ensure that it is not clogged. If you notice that more than 20% of the surface area of the screen is clogged, replace it.
7. Unscrew the plug and remove the spring and the ball. Clean them with gun cleaning solvent.
8. Clean all of the components thoroughly to remove product residue using a cloth moistened with gun cleaning solvent and a brass brush.
9. Make sure the holes of the filter holder cartridge are not blocked by remains of crystallized product. If you see dirt on the mixing head, clean the communication holes using a bit and brass brush.

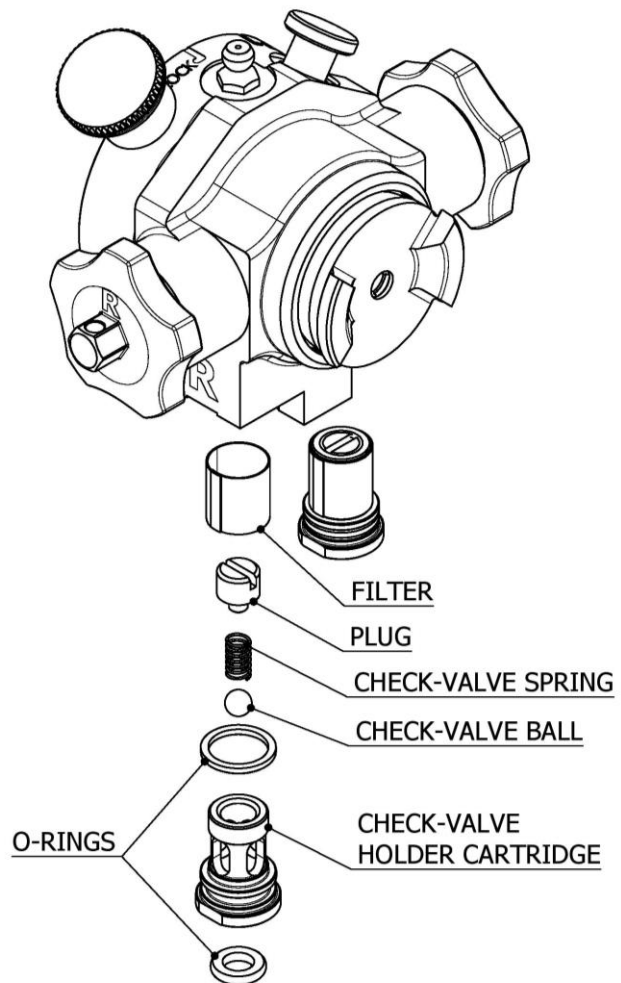



Trigger and valve

WARNING! Before carrying out maintenance work on the gun, make sure that the unit is completely stopped, that all buttons and the main switch are turned off and that the unit is disconnected from the main power supply. The gun is a component that works under pressure. You must not open any connections or carry out maintenance work on components under pressure until the pressure has been completely eliminated.

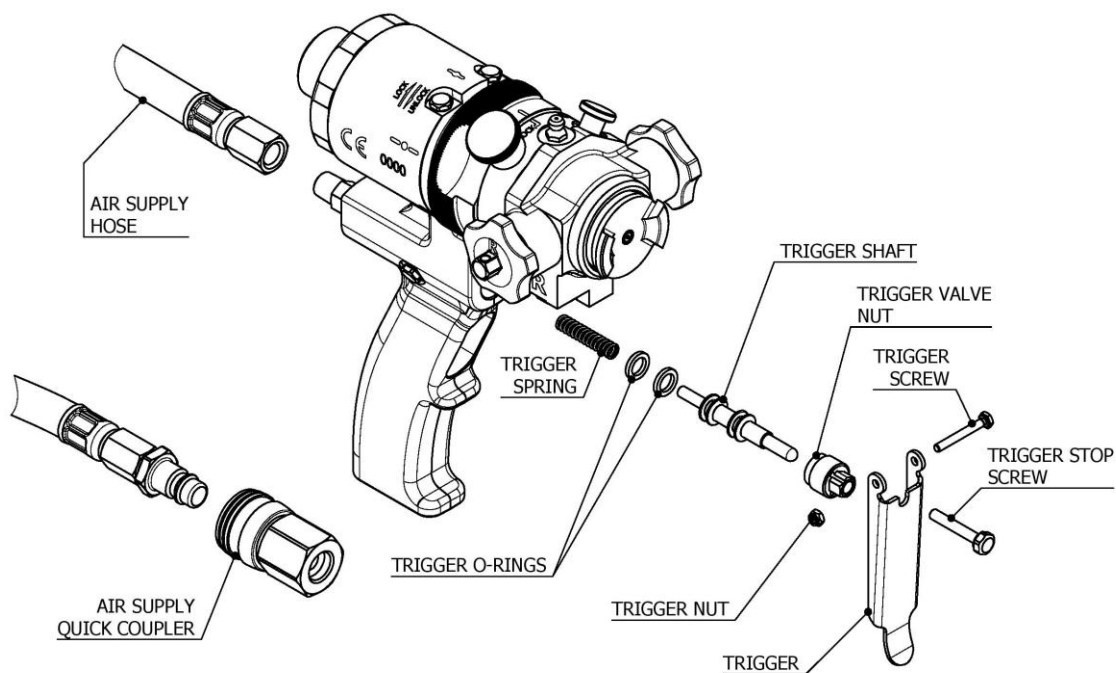

1. Remove the coupling block.
2. Clean the contact surfaces and seals of the check valves cartridges with a cloth moistened with cleaning fluid.
3. Disconnect the air supply hose.
4. Remove the trigger stop screw.
5. Remove the side screw holding the trigger.
6. Unscrew the nut on the trigger valve.
7. Remove the trigger shaft and carefully hold it at the end with pliers to remove it from the housing. The trigger shaft has a spring in the base; be careful not to lose it.
8. Inspect the O-rings on the trigger shaft. Replace them if they are damaged. Apply a little grease to facilitate assembly.



9. Ensure that the trigger shaft housing is free of dirt and apply a small layer of grease inside.
10. Connect the air hose to the back of the gun using sealant paste on the thread to prevent air leaks.
11. Insert the trigger shaft into the spring and insert it into the handle, being careful not to damage the O-rings. You will notice some resistance caused by the interference of the seals with the housing wall.
12. Screw on the trigger valve nut until it stops at the bottom.
13. Attach the trigger and secure it with the side screw.
14. Install the trigger stop screw. Tighten it until it eliminates the play of the trigger (without shifting the axis). Use Teflon or sealant on the thread.
15. Attach the mixing block according to the procedure described in the assembly section of the gun and mixing chamber assembly.
16. Start the gun.

Cylinder block and locking device

WARNING! Before carrying out maintenance work on the gun, make sure that the unit is completely stopped, that all buttons and the main switch are turned off and that the unit is disconnected from the main power supply. The gun is a component that works under pressure. You must not open any connections or carry out maintenance work on components under pressure until the pressure has been completely eliminated.

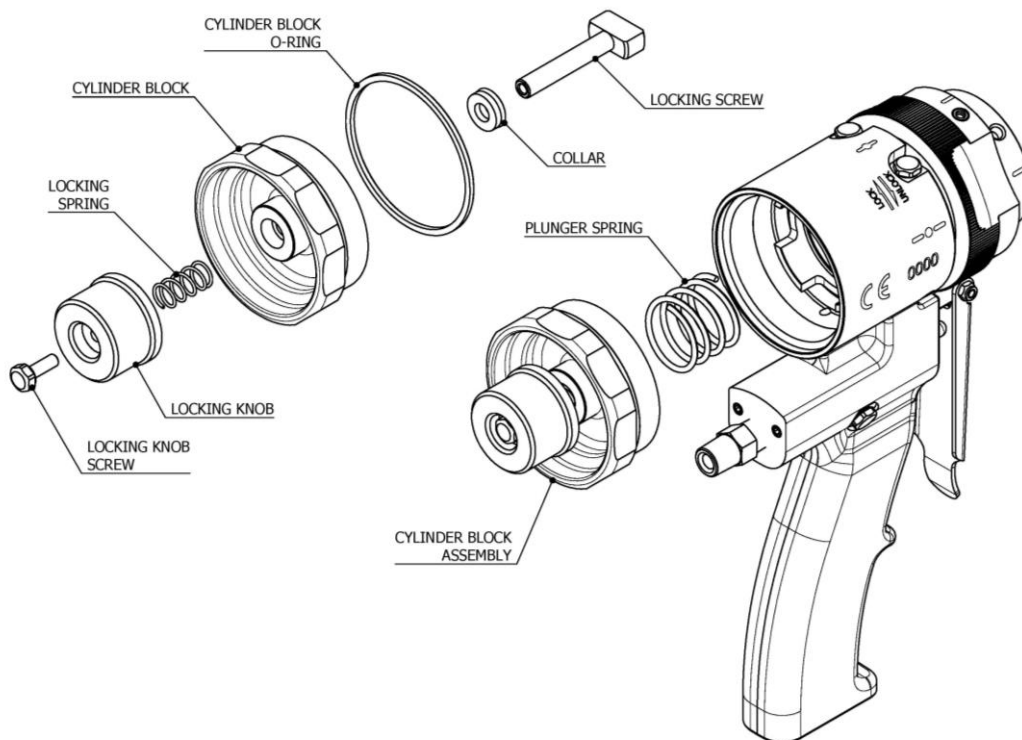



Service Manual

1. Unscrew the cylinder block with the locking mechanism by hand.
2. Also remove the plunger spring.
3. Inspect the condition of the cylinder block seal. Replace it if it is damaged.
4. Apply a little grease to facilitate assembly.
5. Loosen the screw on the lock knob. Remove the locking screw and the locking spring from the device.
6. Remove the cylinder block collar from the cylinder and replace it if it is damaged. Apply a little grease to facilitate assembly.
7. Pay attention to the correct assembly of the collar **the closing lips must face the cylinder side.**
8. Attach the locking screw on the cylinder block. Slide the spring and locking device over the locking screw. Screw on the lock knob anchor screw. Ensure that the locking device is secure.
9. Insert the spring into the rear plunger housing.
10. Insert the cylinder block unit into the cylinder sleeve by screwing it until it stops at the end of the cylinder sleeve. Apply grease around the cylinder block seal.

WARNING! *To ensure that the cylinder block is secured, ensure that the seat face of the cylinder block is in contact with the end of the cylinder sleeve and that the cylinder block seal is not visible from the outside. In case any errors have been made, avoid approaching the cylinder block when applying pressure to the gun after cleaning, repair or maintenance work.*

11. Start the gun.

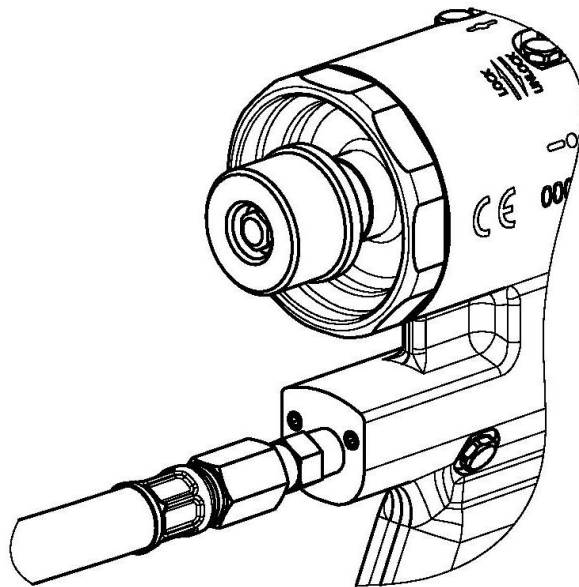



Pneumatic cylinder

WARNING! Before carrying out maintenance work on the gun, make sure that the unit is completely stopped, that all buttons and the main switch are turned off and that the unit is disconnected from the main power supply. The gun is a component that works under pressure. You must not open any connections or carry out maintenance work on components under pressure until the pressure has been completely eliminated.

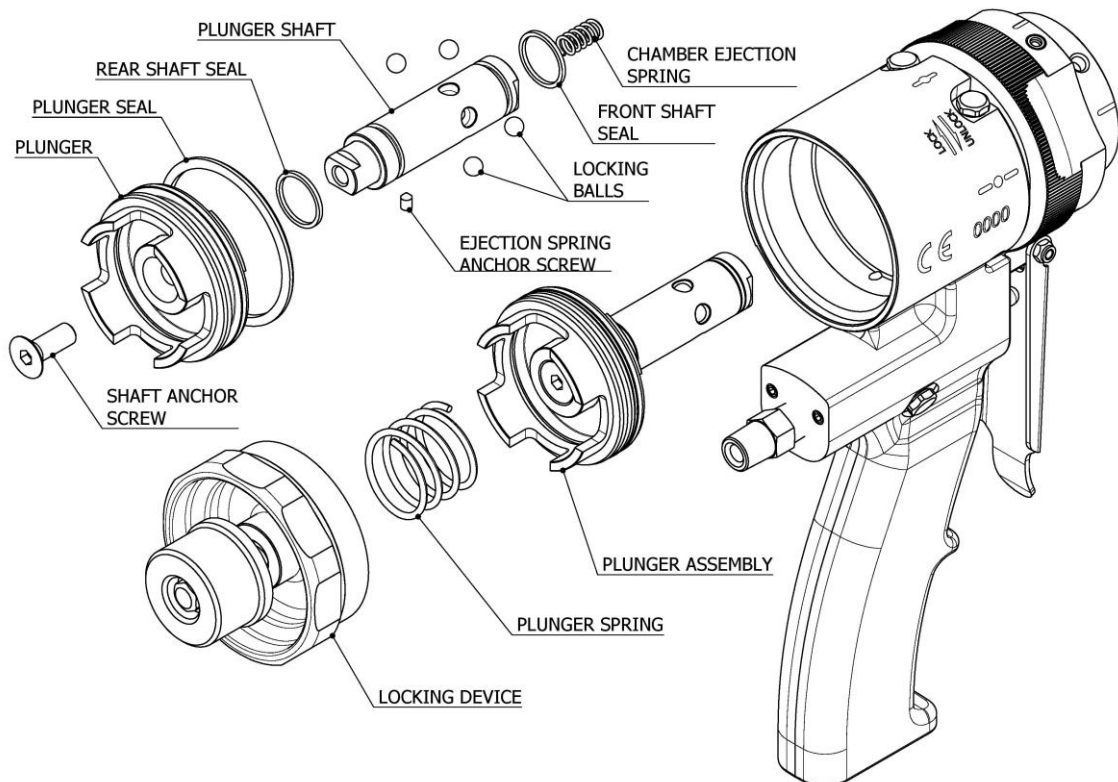

1. Remove the mixing chamber according to the procedure on page 10. Clean the mixing chamber and run a bit through the holes, if necessary.
2. Remove the coupling block.
3. Remove the mixing head as shown on page 9.
4. Manually unscrew the cylinder block with the locking mechanism and plunger spring and pull the entire unit out.
5. From the front of the gun, push the cylinder shaft and pull the entire plunger assembly out of the sleeve. Keep track of the five balls and the inner spring housed in the shaft.
6. Inspect the condition of the cylinder block seals (2), the plunger shaft (2) and the plunger (1). Replace them if they are damaged. Apply a little grease to facilitate assembly.



Service Manual

7. Apply a sufficient amount of grease to hold the balls in the shaft housings and check that the screw that holds the inner spring is properly tightened and secured with thread lock.
8. Insert the plunger assembly into the cylinder sleeve taking special care not to damage the O-rings.
9. Insert the plunger spring into the rear plunger housing.
10. Insert the cylinder block unit into the cylinder sleeve by screwing it until it stops at the end of the cylinder sleeve. Apply grease around the cylinder block seal.

WARNING! *To ensure that the cylinder block is secured, ensure that the seat face of the cylinder block is in contact with the end of the cylinder sleeve and that the cylinder block seal is not visible from the outside. In case any errors have been made, avoid approaching the cylinder block when applying pressure to the gun after cleaning, repair or maintenance work.*

11. Assemble the spray head as shown on page 9.
12. Insert the chamber according to the procedure on page 12.
13. Tighten the side cartridges.
14. Attach the coupling block and install the diffuser.
15. Start the gun.

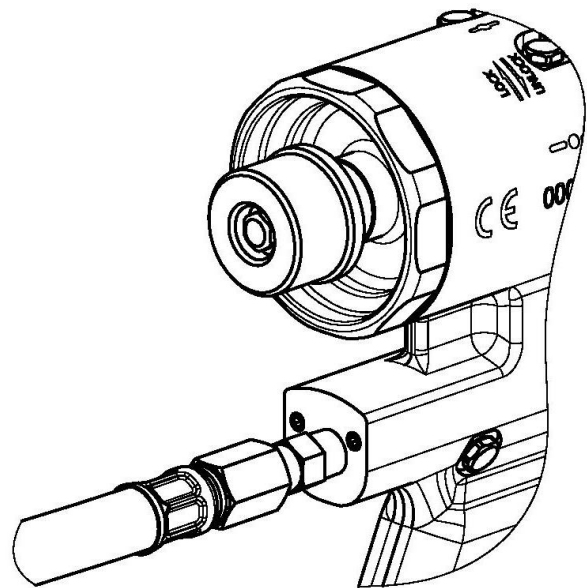



CONTENT

Warranty	2
Safety and Handling	3
Method of Threaded Union of the Hoses	4
Characteristics	7
Specifications	7
General Description	8
Attaching the Mixing Head	9
Removing the Mixing Head	11
Inserting and Ejecting the Mixing Chamber	12
Installation and Start-Up	15
Shutdown Procedures	18
Maintenance	20
Gun block and mixing chamber unit	21
Side cartridge unit	24
Filter and Check Valve Cartridge Unit	25
Trigger and valve	27
Cylinder block and locking device	28
Pneumatic cylinder	30
Content	32